

AM · FM · TELEVISION  
**BROADCAST**  
NEWS

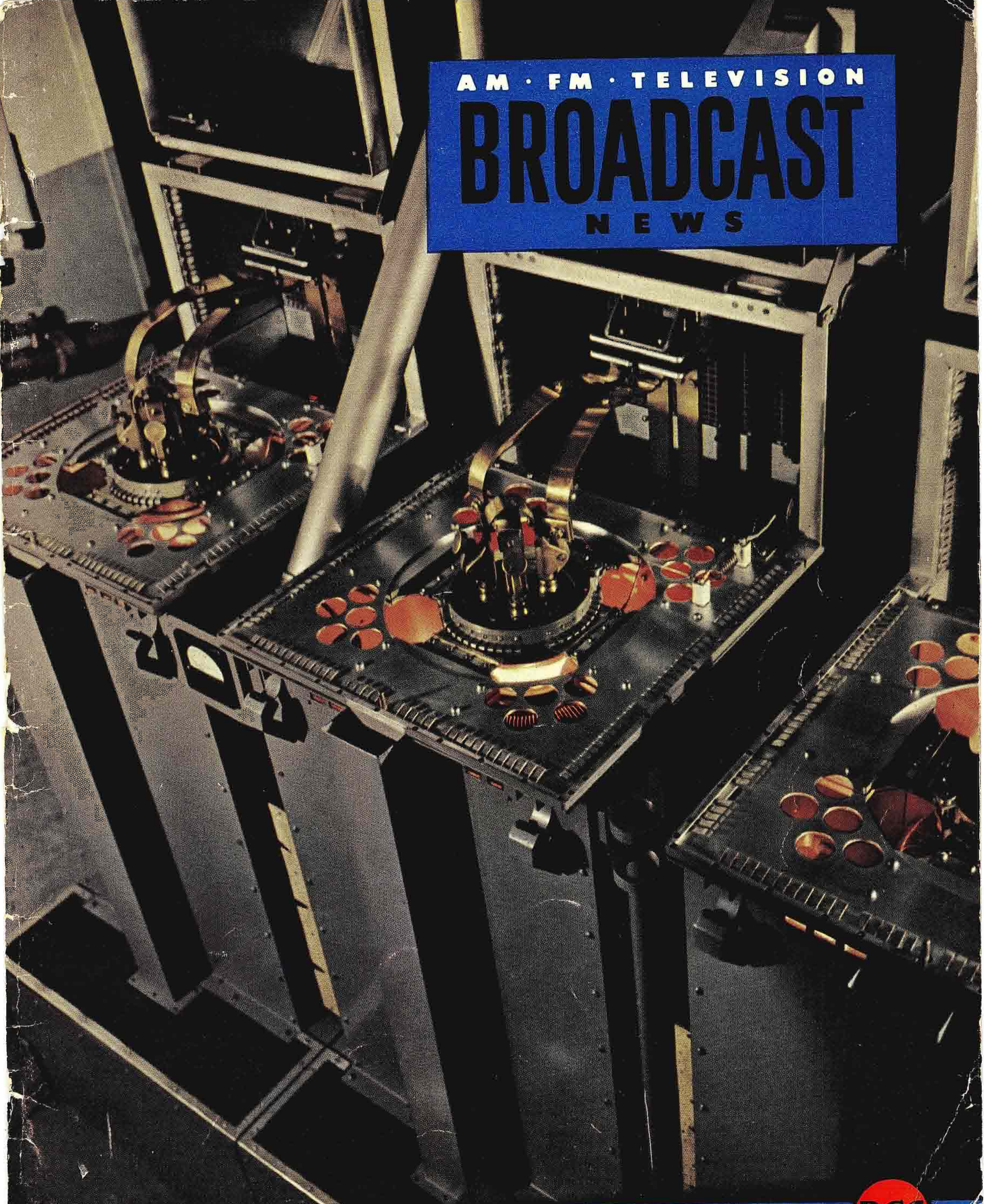

50 KW. FM TRANSMITTER . . . . . See pg. 8





*The one company that  
has everything for  
every broadcaster*

**A M**

**F M**

**T V**

At each of the following locations you  
will find a broadcast specialist who is  
ready to help you with your problems:

36 W. 49TH ST.  
NEW YORK 20, N. Y.

502 CITIZENS & SOUTHERN BANK BLDG.  
ATLANTA 3, GA.

1355 MARKET ST.  
SAN FRANCISCO 3, CALIF.

718 KEITH BLDG.  
CLEVELAND 15, OHIO

221 W. 18TH ST.  
KANSAS CITY 8, MO.

1560 N. VINE ST.  
LOS ANGELES 14, CALIF.

666 N. LAKE SHORE DRIVE  
CHICAGO 11, ILLINOIS

1907-11 McKINNEY AVE.  
DALLAS 1, TEXAS

2400 3RD AVE.  
SEATTLE, WASH.



**BROADCAST EQUIPMENT**  
**RADIO CORPORATION of AMERICA**  
**ENGINEERING PRODUCTS DEPARTMENT, CAMDEN, N.J.**

In Canada: RCA VICTOR Company Limited, Montreal

# Broadcast News

AM • FM • TELEVISION

Published by the

**RADIO CORPORATION OF AMERICA**

ENGINEERING PRODUCTS DEPARTMENT . . . CAMDEN, NEW JERSEY

NUMBER 53

FEBRUARY, 1949

Subscription Rate \$2.00 per year.

Single Copy 50c.

JOHN P. TAYLOR, Editor

JUDY J. ALESI, Ass't Editor

W. O. HADLOCK, M. L. GASKILL, Associate Editors

## Contents

HOW TO SHOCK MOUNT 70 SERIES TURNTABLES . . .	by W. E. STEWART	7
BTF-50A, 50 KW FM TRANSMITTER . . . . .	by C. J. STARNER	8
THE 50 KW FM POWER CUTBACK SWITCH. . . . .	by C. J. STARNER	18
WTMJ-FM . . . WORLD'S FIRST "SUPER-POWER" FM	by PHILLIP B. LAESER	20
WBRC-FM . . . WORLD'S MOST POWERFUL FM STATION	by G. P. HAMANN	26
8-SECTION PYLON MAKES 546 KW A REALITY AT WBRC-FM	by O. O. FIET	32
HOW TO MAKE FM PROOF-OF-PERFORMANCE MEASUREMENTS	by F. E. TALMAGE	36
WGPA, 250 W AM — 3 KW FM . . . . .	by ARTHUR McCRACKEN	44
WMPS . . . MEMPHIS' 10 KW AM . . . . .		46
IMPROVED LACQUER DISK RECORDING HEAD . . . . .	by H. E. ROYS	50
CMQ — HAVANA'S KEY STATION . . . . .		54
BROADCASTING STUDIO PICKUP TECHNIQUE . . . . .	by H. M. GUERIN	58
ABC PIONEERS WITH MET TV . . . . .		66
PHILOSOPHY OF OUR TELEVISION SYSTEM . . . . .	by J. H. ROE	73

Copyright  
Radio Corporation of America  
RCA Victor Division  
Camden, N. J.

PRINTED  
IN  
U.S.A.

**OUR COVER**, appropriately we think, is a Kodachrome of the power amplifier tank circuits of the new BTF-50A KW FM Transmitter described in Charlie Starners' article beginning on Page 8. This photo was made in the transmitter laboratory by Jim Gaynor, Manager of our photographic department. The red glow is the reflection of the filaments in the big tubes from the copper-lined interior of the tank elements.

**SUPER-POWER FM** is no longer confined to the laboratory. As this is written three RCA 50 KW FM transmitters are on the air—and several others are underway. Two of these installations, WTMJ-FM, Milwaukee and WBRC-FM, Birmingham, are described at some length in this issue. The third, WMCF, Memphis, has been on only a short time and we have not yet received a description. However, we're hoping to have this in a forthcoming issue (Ed Frase, please note). It should be a dandy too, because WMC has not only AM and FM, but also TV, all in the same building and all radiated from the same tower. This is the first time this has been done commercially, and Ed reports that it works f.b. in all respects. WTMJ-FM and WBRC-FM articles (Pages 18 and 24, respectively) are noteworthy, we think, for the wealth of information on how the equipment was actually installed. The photographs (particularly behind-the-panel views) and floor plans should be of considerable help to station engineers planning similar setups.

**PHILOSOPHY** is a new word for BROADCAST NEWS. Ordinarily our pages are reserved for the practical aspects of broadcast engineering and operation—the "how-it-was-done" and "how-to-do-it" kind of articles. Anything that smacks of theory we avoid like the plague. But in TV engineering we encounter a somewhat different situation. Here is a field with which the average station engineer has had almost no contact. Chances are he hasn't, until very recently, paid any attention at all to it. And yet it is not a new field. RCA engineers, and others too, have been working continuously on TV development for over twenty years. They have gone through some six or seven distinct stages (different number of lines, different frequency bands, etc.). At each of these stages meetings were held with industry and FCC engineers. Problems were discussed mutually and forward-looking standards adopted. It was in this way that our present TV system was established (those who are interested in the detailed record will find it in Don Fink's book, "TELEVISION STANDARDS AND PRACTICE—N.T.S.C.").

A broadcast station engineer, faced with the problem of becoming a TV expert "overnight," will more easily understand the working of the TV system—as a system—if he is familiar with the background thinking on which our present TV standards are based. John Roe's article on "The Philosophy of Our TV System" (Page 73) explains some of this thinking—and hence we feel is important reading for every TV neophyte.

John's article is so long we plan to run it in three installments in the next three issues of BROADCAST NEWS. However, if you can't wait for "the next episode" we will (on request) send you a preprint of the whole thing.

**NAB ENGINEERING MEETING** at the Stevens Hotel, Chicago, April 6-9, promises to be the biggest and best yet. Doc Howard and Neil McNaughton are working up a list of engineering papers which will set a new high in practicality and usefulness. And they'll be the things you are interested in—for the list of subjects has been drawn from the answers to the questionnaire sent out by NAB.

In addition to the papers, the equipment exhibits promise to be even bigger and more interesting than ever. As usual we will have most of our current equipment items on display—plus a number of new things which will be unveiled for the first time. We'll have lots of space—and lots of easy chairs. Make our booth your headquarters.

# RCA Heavy-Duty **FM** Pylon

- **Completely self-supporting**
- **Supports the RCA High-Gain TV Antenna**
- **Does away with need for extra tower**
- **Power gain 3 and 6**
- **Handles 50 kilowatts**

The lower part of the antenna you see in these pictures is a high-gain, heavy-duty Pylon. It can support a 6-section RCA high-gain television antenna . . . *without a single guy*. No need for a separate tower for FM . . . with the expense of putting up another tower later for TV. *Here, one does it!*

For long-term protection of your tower investment, be sure to figure your FM-TV antenna requirements in terms of a Heavy-Duty Pylon—TV Super Turnstile combination. Your RCA Broadcast Sales Engineer has the facts. Call him, or write Section 19-C, Engineering Products Dept., RCA, Camden, N. J.

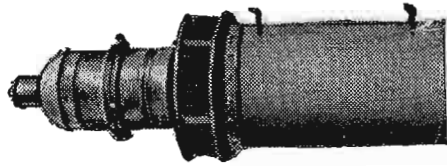
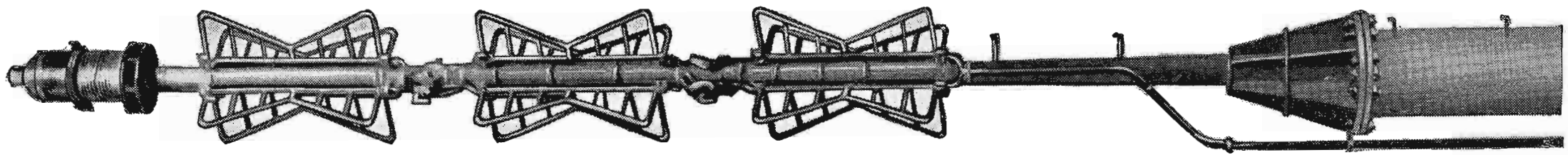

**NOW...**  
for FM

You install a two- or four-section Heavy-Duty Pylon now. You simply bolt a wide-band, high-gain TV antenna atop it later. Benefits: maximum coverage for FM now. Maximum coverage for FM and TV later.

The "Heavy-Duty" antenna is simplicity itself. No dipoles. No external loops. No appendages of any kind... and no adjusting.

The Heavy-Duty Pylon with a High-Gain TV Super Turnstile atop it. Two antennas in a single self-supporting unit that can be mounted anywhere—tower or building. This radiator provides simultaneous FM transmission and wide-band TV services—both aural and visual. Power gain for the Super Turnstile is 3.8 to 7.

**LATER...**  
for FM and TV

**QUICK-SELECTION CHART FOR RCA FM AND TV ANTENNAS**

Choose the unit or the combination to meet your special requirements.

**HEAVY-DUTY PYLONS**

FREQ. RANGE (MC)	POWER GAIN	NO. OF SECTIONS	OVER-ALL HEIGHT (FT.)	WEIGHT (LBS.)	TYPE NO.
88-96	3	2	27	4,322	BF-12E
96-108	3	2	27	4,322	BF-12F
88-96	6	4	54	10,497	BF-14C
96-108	6	4	54	10,497	BF-14D
<b>TELEVISION SUPER TURNSTILES (for installation on Heavy-Duty Pylons)</b>					
55-66	3.3 to 3.7	3	56' 3"	4,666	TF-3B
66-88	3.3 to 4.1	3	48' 1"	3,120	TF-3B
174-216	6.4 to 7.1	6	44' 8"	2,770	TF-6B

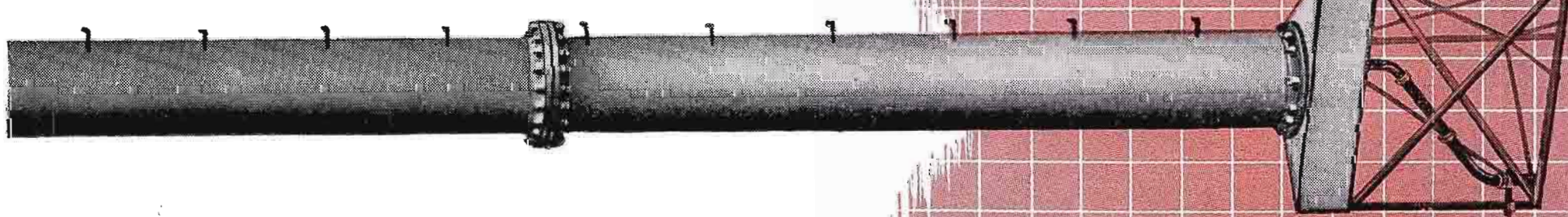
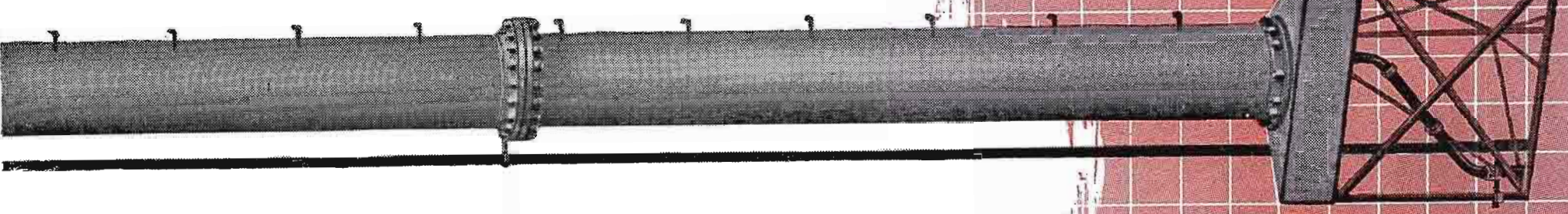

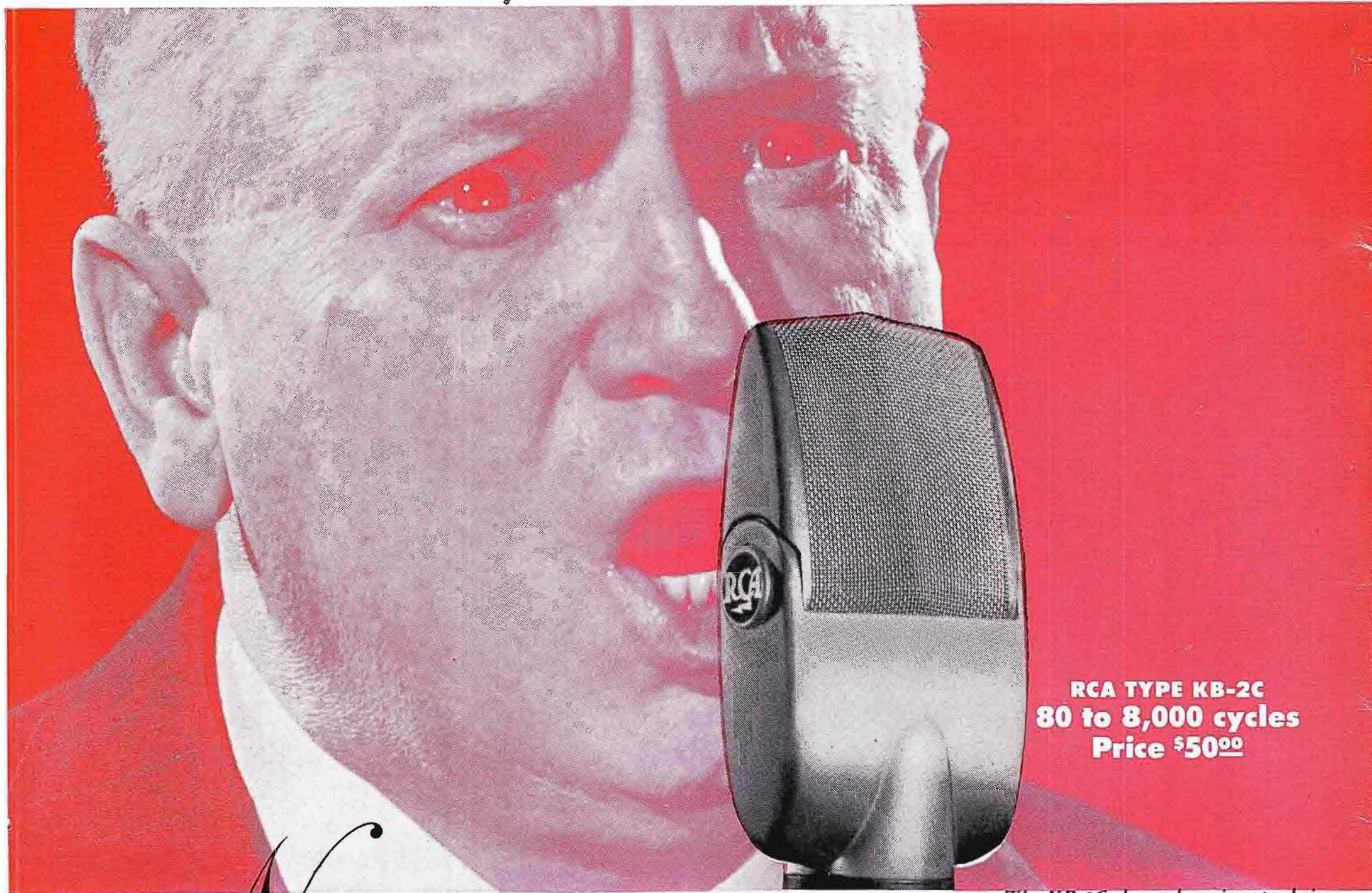

**RCA TYPE KB-2C**  
**80 to 8,000 cycles**  
**Price \$50<sup>00</sup>**

*The KB-2C shown here is actual size.*

# New **VELOCITY MICROPHONE** *Bantam Size!*

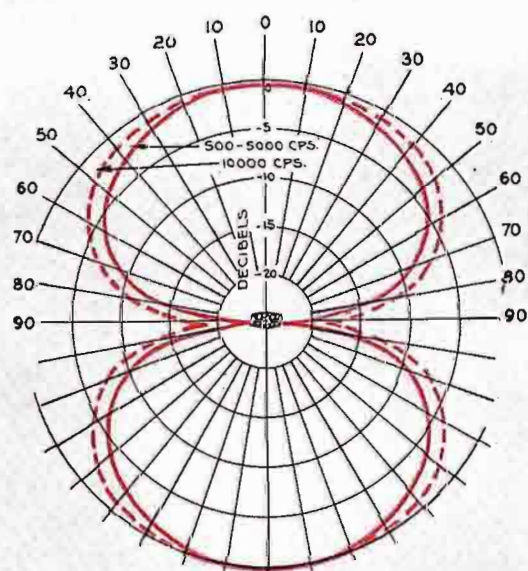

**Directional characteristics of a typical KB-2C microphone.**

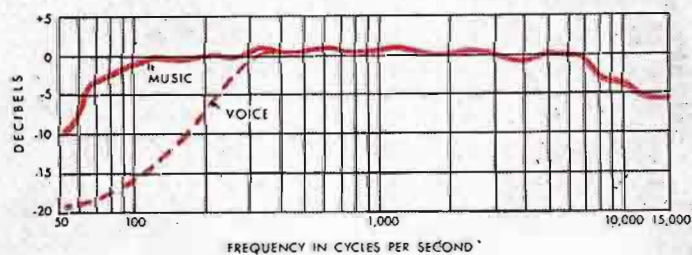

**Open Circuit Frequency Response of a typical KB-2C microphone.**

**B**ECAUSE this man is talking into the new miniature KB-2C, his audiences hear him . . . and see him! Hear him—because the KB-2C has “big mike” quality. See him—because the KB-2C is one of the *smallest* high-quality microphones yet designed. It’s ideal for conventions and night clubs. And it’s ideal for general station and other indoor uses.

Using highly efficient magnetic material . . . and a magnet structure *that’s a part of the microphone case itself*, here’s a microphone that’s as “light as a feather”—and so small it fits into your pocket. Its directional characteristics provide a symmetrical figure eight . . . with surprisingly uniform frequency response between 80 and 8,000 cps. Hum level, -108 dbm. Effective output

level, -56 dbm. Three output impedances provided; 30, 150, and 250 ohms, in accordance with RMA standards.

Plenty of operating conveniences, too. You can tilt the KB-2C backward and forward on its swivel through an angle of about 30 degrees. You can select your bass response by means of a screwdriver-type switch located under the swivel pivot. You can disconnect the cable right at the microphone. For desk positions, use RCA’s type KS-2A low-height stand. For other services, use any standard floor stand or collapsible stand.

. . .

More about the 12-ounce KB-2C from your RCA Broadcast Sales Engineer. Or write Dept.



**BROADCAST EQUIPMENT**  
**RADIO CORPORATION of AMERICA**  
**ENGINEERING PRODUCTS DEPARTMENT, CAMDEN, N. J.**

In Canada: RCA VICTOR Company Limited, Montreal



## RCA *Audio Accessories*

**FOR EVERY STATION NEED—AM·FM·TV**

Available now for immediate delivery—  
more than 100 high-quality items to meet  
your installation requirements

MAIL THIS COUPON FOR YOUR FREE COPY

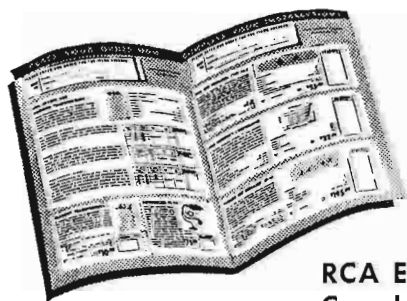

RCA'S NEW AUDIO ACCESSORY  
BULLETIN—

*KEEP IT  
HANDY!*

RCA Engineering Products Dept.  
Camden, New Jersey

Please send me my copy of your bulletin on RCA's Audio  
Equipment Accessories.

Name \_\_\_\_\_

Address \_\_\_\_\_

Station \_\_\_\_\_ Position \_\_\_\_\_

City \_\_\_\_\_ State \_\_\_\_\_

REPRESENTED HERE are items from broadcasting's most complete line of fine audio accessories. Microphone stands . . . studio warning lights . . . cabinet racks . . . panel-mounted auxiliary units . . . transformers of many kinds. In all, more than 100 different items—with every type of unit you need from large size cabinet racks down to patch cords.

Designed by audio men *for audio men*, these accessories are built with the professional thoroughness needed to meet the most exacting requirements of broadcast use. Mechanically and electrically, every unit is built to "take it."

For information on RCA's complete line of audio accessories . . . immediately available from stock . . . call your RCA Broadcast Sales Engineer, or Dept. 7-G, Engineering Products, RCA, Camden, New Jersey.



**BROADCAST EQUIPMENT**

**RADIO CORPORATION  
of AMERICA**

ENGINEERING PRODUCTS DEPARTMENT, CAMDEN, N.J.

In Canada: RCA VICTOR Company Limited, Montreal



TYPE 70-D  
RCA HIGH-FIDELITY  
TRANSCRIPTION TURNTABLE

# Standard of the Studios—NEW EDITION

Over 3000 units of this professional series are now in use

● Type 70-D is designed specifically to meet your needs for higher and higher reproduction quality in studio transcriptions.

In this unit—latest of the "70 series"—you will find all the exclusive features of the previous models . . . and important new ones. There's the universal lightweight pick-up with the diamond-point stylus . . . unexcelled for high-fidelity characteristics on either vertical or lateral recordings. And the mechanical filters and spring clutch assembly

that *completely* isolate the driving motor from the platter and fly-wheel assembly.

There's the heavy-duty, constant-speed synchronous motor with all the driving power you need for recording *and reproducing* at 33 $\frac{1}{3}$  or 78 rpm. And there's the handsome new hinged-door *metal* cabinet with its durable formica top . . . with the inside space to house booster amplifiers and record cueing amplifiers . . . and with accommodations on the formica top for adding an RCA.

72-D or 72-DX Recording Attachment when you decide to go into recording.

For the finest response from your recording . . . for dependable timing to the very last second . . . for even running and smooth starts and stops, this studio turntable has it! Available in two cabinet-top heights . . . 28 inches and 30 inches. Equipped with convenience-plug outlets for a-c and audio circuits. Ask your RCA Broadcast Sales Engineer for complete data, or write Dept. 115-L.

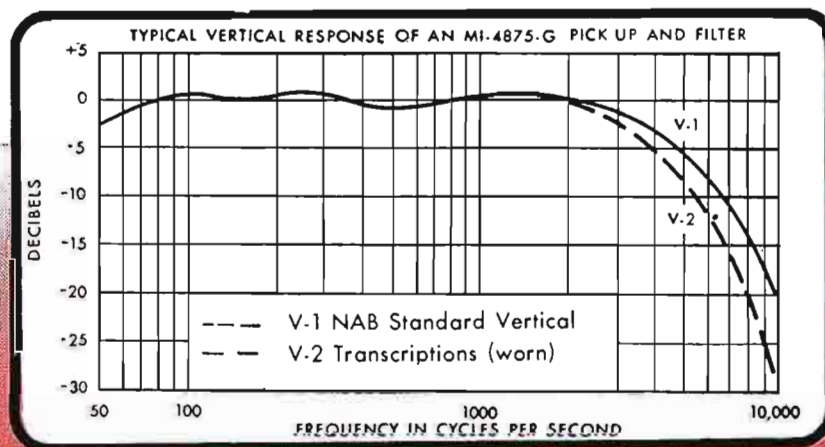
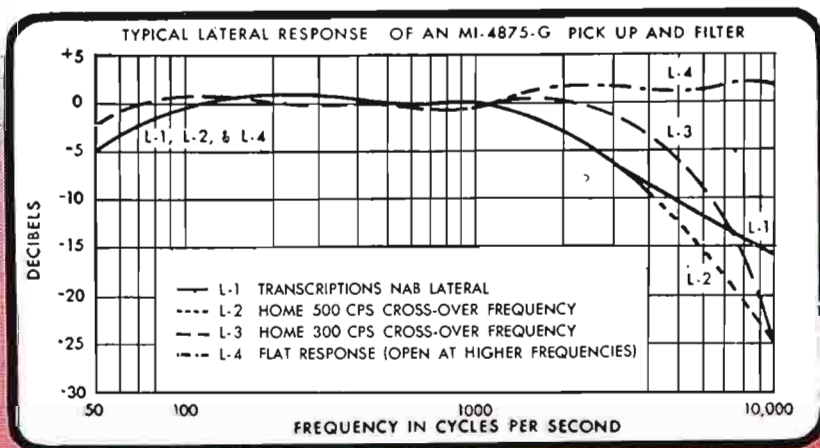

**BROADCAST EQUIPMENT**  
**RADIO CORPORATION of AMERICA**  
**ENGINEERING PRODUCTS DEPARTMENT. CAMDEN, N.J.**

In Canada: RCA VICTOR Company Limited, Montreal



# HOW TO SHOCK MOUNT 70 SERIES TURNTABLES

by **W. E. STEWART**

Audio Engineering Section

Engineering Products Department

Transcription turntables are often used in control rooms and other positions where there is not much isolation from building noises. Elevators, heavy walking, and other forms of vibration can be heard in the quiet passages of transcriptions. There is a simple method to check the level of such noise. First play the 1000 cycle note of a standard test record, such as the Victor Record #460625-6. Set the levels of the transcription amplifiers so the VU meter reads zero. Then, leaving the pickup in the groove of the record, turn off the motor and stop the turntable. Turn up the gain control in the channel until the building rumble can be read on the VU meter. If the gain control is raised 20 db and the meter reads -20 VU the noise level can be said to be 40 db below standard record level. Frequently the noise is very irregular in form and requires a comparatively long observation of the meter. The pickup should be lifted from the groove with the finger to check whether the noise is mechanically transmitted from the turntable or comes from electrical sources in the channel.

The ideal method to filter out noise from the floor is to mount a heavy slab of concrete on springs or rubber so that the resonant frequency of the system is very low, say 10 cycles per second, when the turntable is mounted on it. Such an arrangement can be made for factory test positions, but usually is not practical in a control room or studio. Fortunately a simpler method is available that will sufficiently improve many turntable locations.

In our design laboratories, Mr. W. E. Newman, turntable design engineer, set up

a simple vibration table and mounted a 70-D turntable on it. He then adjusted the 30 cycle vibration frequency of the table until a rumble level of -40 db was observed. The turntable was then separated from the vibration table by three shock mounts which are described below. This resulted in a reading reduced to -46 db, or 6 db improvement with the mounts at 30 cycles. Higher frequencies would show greater improvement. A reading taken with and without the mounts on a factory floor indicated about the same 6 db improvement.

Out of several combinations tried the best mount appeared to be a pad made of sponge rubber. A kneeling pad  $\frac{1}{2}$  inch thick from a dime store supplied the material. Three pieces of  $\frac{1}{4}$  inch plywood were cut out 3 x 3 inches. A  $1\frac{1}{2}$  inch diameter hole was bored in the center and through only the top layer of each plywood square. A 3 inch square of the sponge rubber was cemented to the bottom of each piece of plywood. A layer of heavy bond paper was cemented to the bottom of the rubber. One pad was slipped under each glide of the turntable. The recess in the plywood supplies positioning for the glide to prevent its slipping off the mounts. The paper prevents the rubber from cementing to the floor with age.

This mount raises the turntable only half an inch higher than normal and provides stability as well as isolation. The load is light enough to give reasonably long life to the rubber pads, though no tests have been made of this feature, and will depend on the material chosen.

Larger, smaller, and double thickness combinations were tried with little improvement. Some combinations gave a wobbly and unstable mount for the turntable.



FIG. 1. View of popular RCA type 70-D turntable equipped with three simple sponge rubber shock mounts which effect an improvement of 6 db.

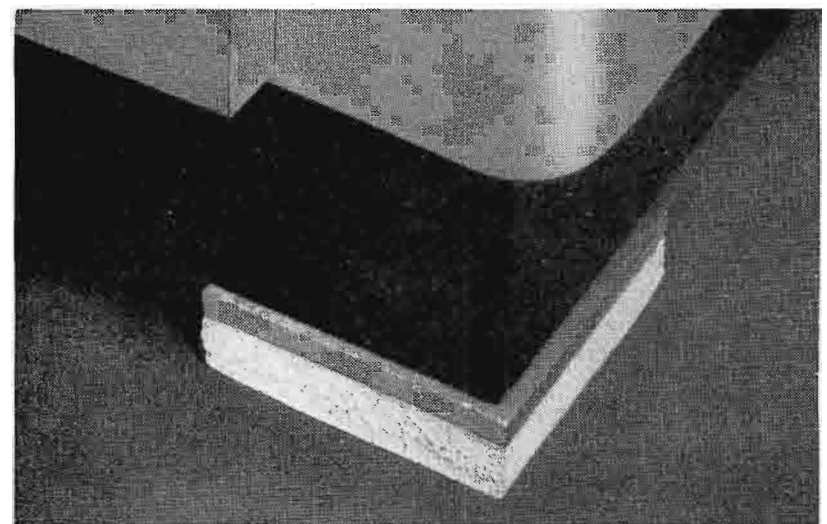

FIG. 2. Closeup of the shock mounting which elevates the turntable only one-half inch.

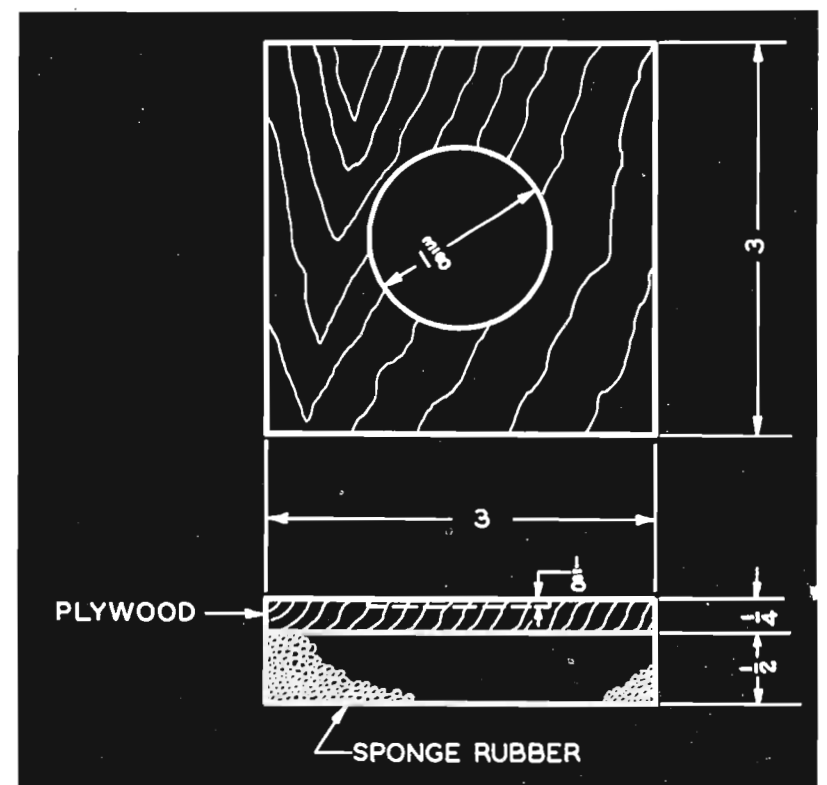

FIG. 3. Sketch showing constructional details of the sponge-rubber shock mountings, which are made of inexpensive, easily-obtained materials.

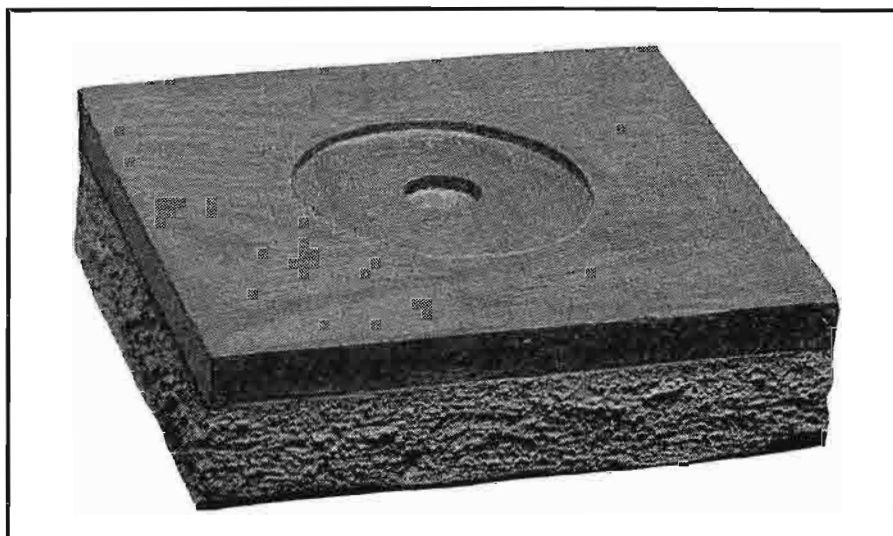

FIG. 4 (at left). Only three, easy-to-construct mounts like the one shown here are required. Note that top of shock mount is recessed to accommodate the turntable glide button and to avoid slippage of turntable.

# BTF-50A, 50-KW FM TRANSMITTER

C. J. STARNER

Transmitter Engineering Section  
Engineering Products Department

As frequency modulation became established as a broadcasting service the need arose for 50 KW transmitters in the frequency range from 88 to 108 megacycles. To produce a transmitter of this power presented a major problem to both the tube and circuit designer calling for laboratory development in advance of actual commercial design. It is the intent of this article to give a brief history of the development of a 50 kilowatt FM transmitter and to describe the final design of a commercial equipment.

## Development

Circuit development was conducted simultaneously with the development of a suitable high power tube since, to a great extent, the circuit at these frequencies is dependent on the tube design and must necessarily be contingent upon tube development. Work on the amplifier was first started at 50 mc since this frequency was in the range then employed. It was felt that a conventional type triode used in a grounded-grid circuit offered the greatest

possibilities for reliability and simplicity, while the use of air cooling provided simplicity of equipment and minimum maintenance. Accordingly, an air-cooled triode was produced with a special low inductance grid header, and with inter-electrode spacing insuring adequate efficiency (minimized transit time effect). At the same time an amplifier using special open line tank circuits was set up for test.

First tests were successful in producing stable power, but also brought to light problems in tube and circuit design, such as the necessity for a high conductivity seal between metal and glass and the need, from a circuit standpoint, for careful attention to current distribution from circuit elements to tube connections. Radiation problems were also encountered.

Calculations indicated that the tube developed for 50 megacycles, with minor modifications and with slight derating could be used for the 88 to 108 mc range. The amplifier circuit, while satisfactory at 50 megacycles was not satisfactory for use at

108 megacycles and was therefore replaced by a circuit having a concentric line type of construction. Experience gained at 50 megacycles indicated the advantages of parallel tube operation over push-pull operation. In the case of parallel operation adjustment proved much easier and design became simpler as there is no problem in driving from a single ended stage and feeding an unbalanced load. From the standpoint of harmonic radiation push-pull operation offers no real advantage since it is impossible to eliminate electrostatic coupling from the load. However, air-cooled tubes large enough to produce 20 kilowatts at 108 megacycles are necessarily large in terms of a quarter wave length, and it seemed doubtful whether they could be coupled tightly enough to really operate in parallel without going into push-pull operation or producing parasitic frequencies. Three identical amplifiers were built. One amplifier was used to drive the other two operating in parallel and feeding a common load. Precautions to prevent radiation were taken to the extent that all con-

FIG. 1 (below). The BTF-50A block diagram below illustrates how simplified circuit design was followed throughout to reduce tubes and transmitter components to a minimum. "Direct FM," grounded-grid circuits, single-ended amplifiers and instantaneous power cutback are typical features included.

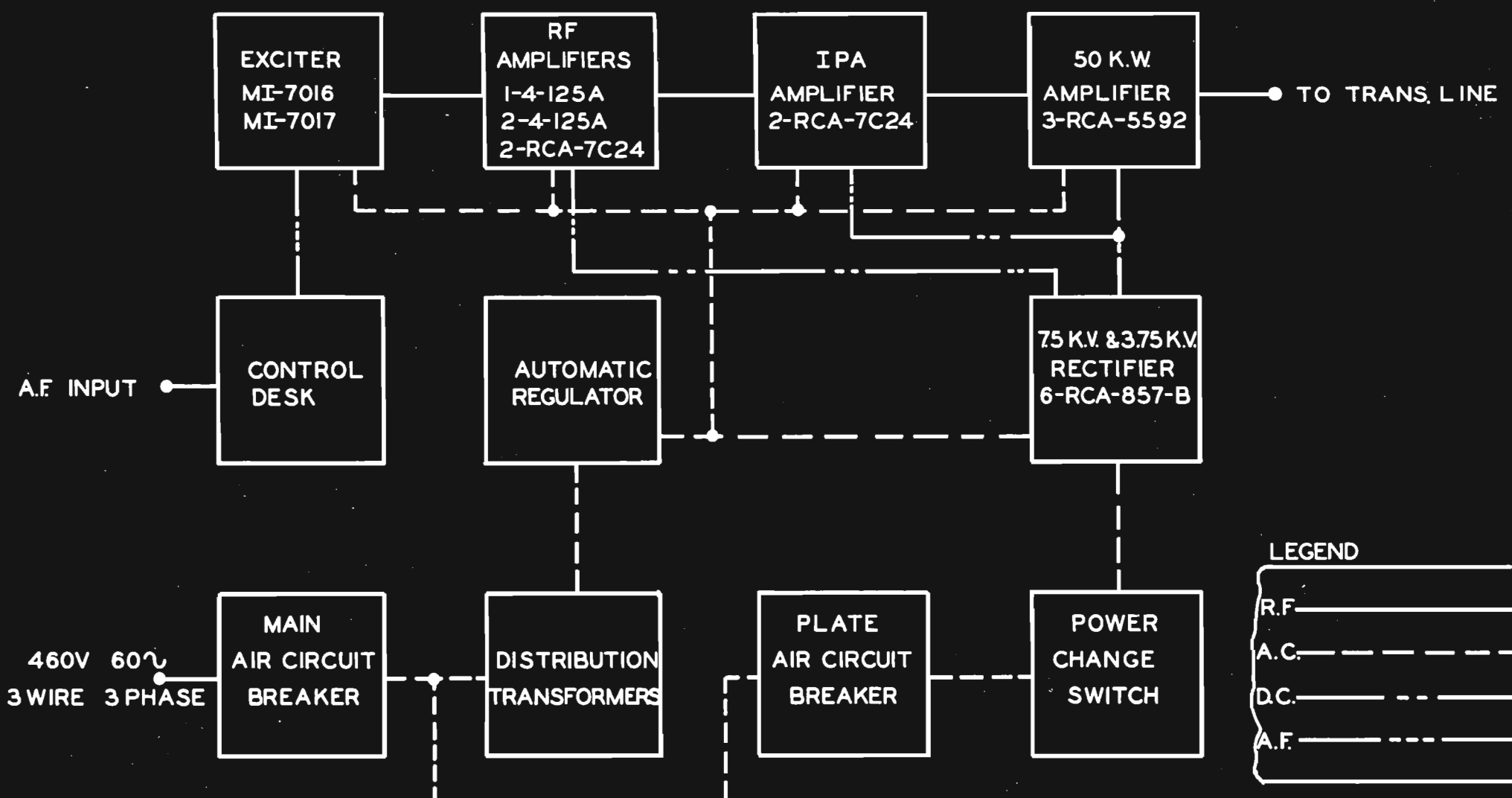

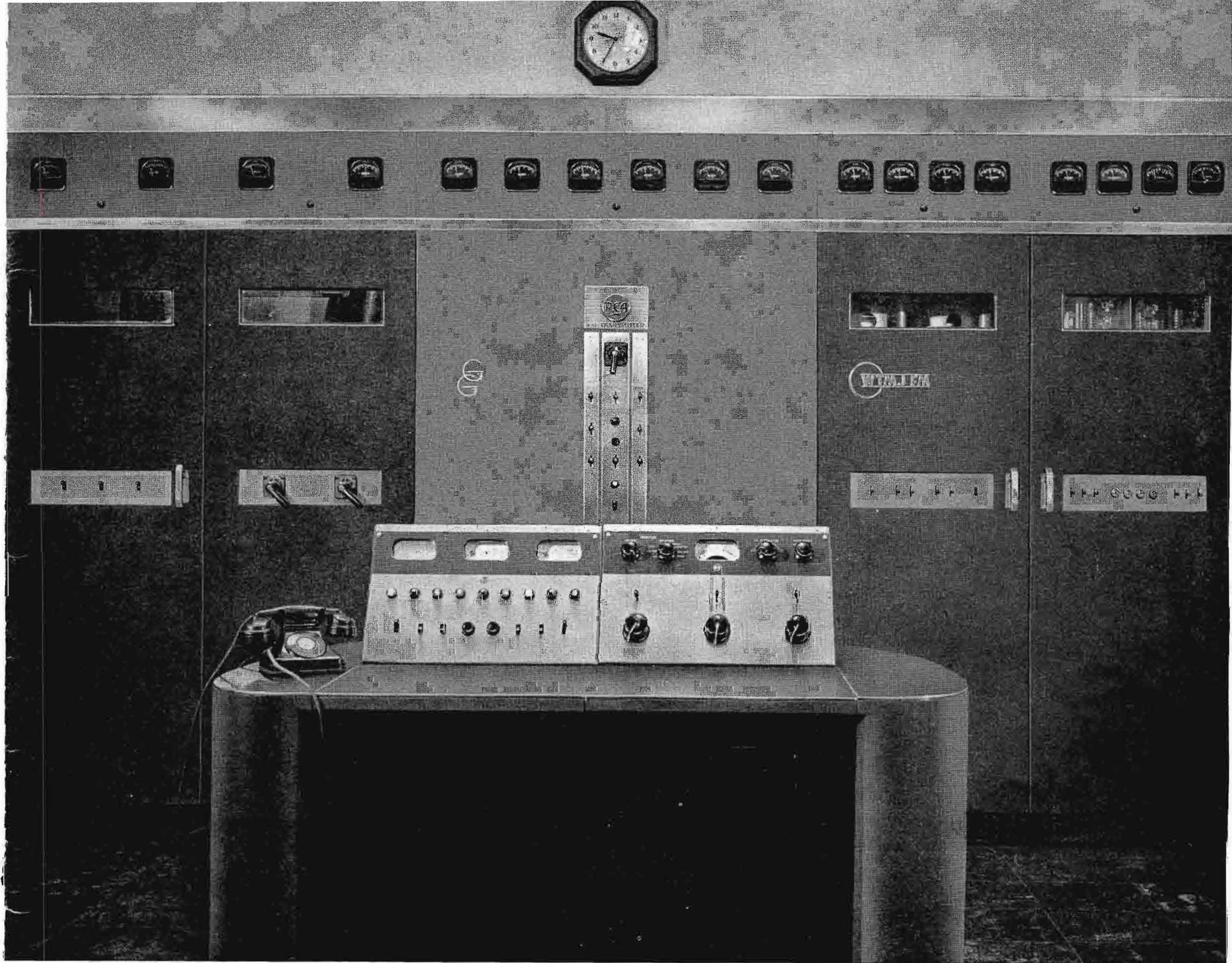
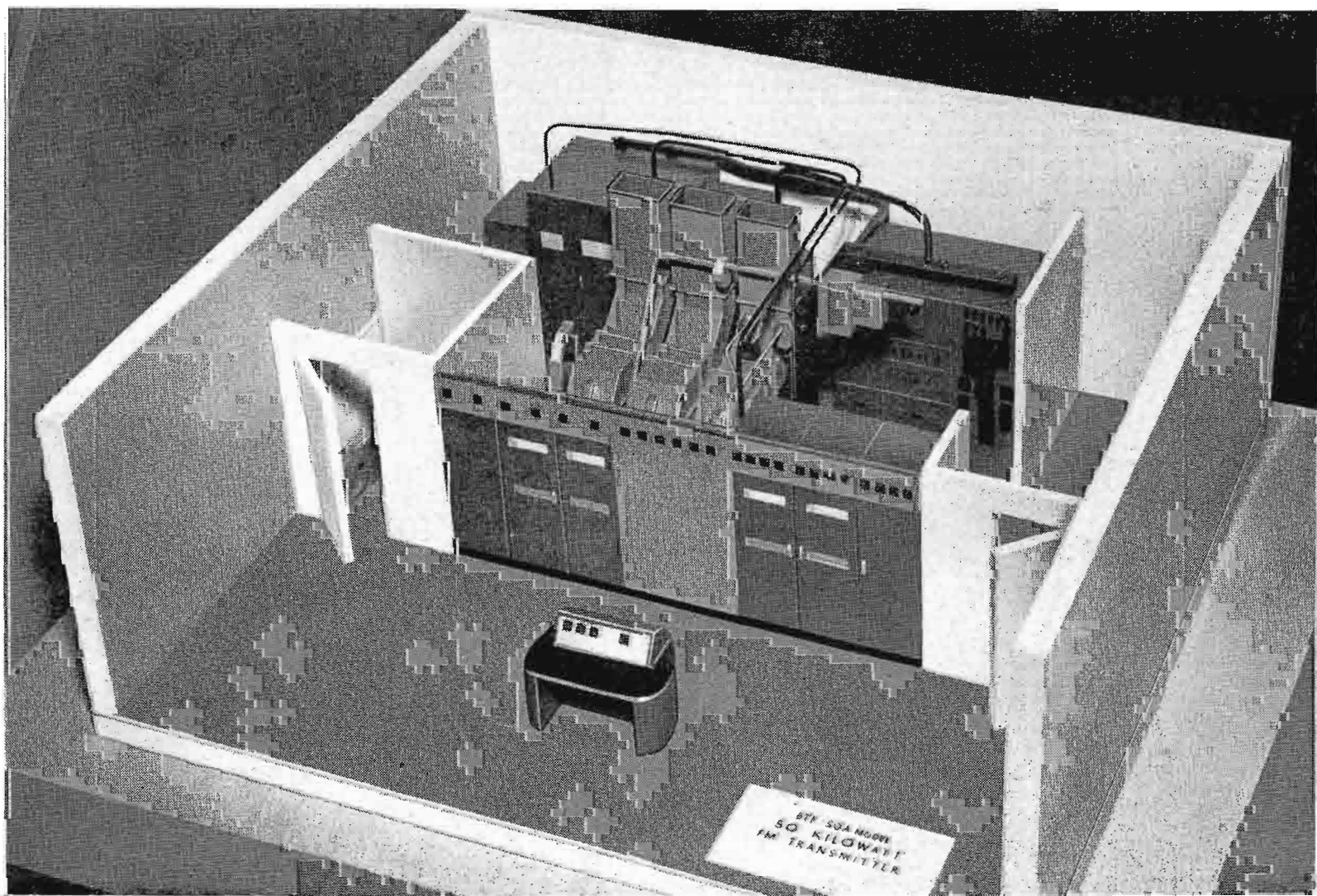
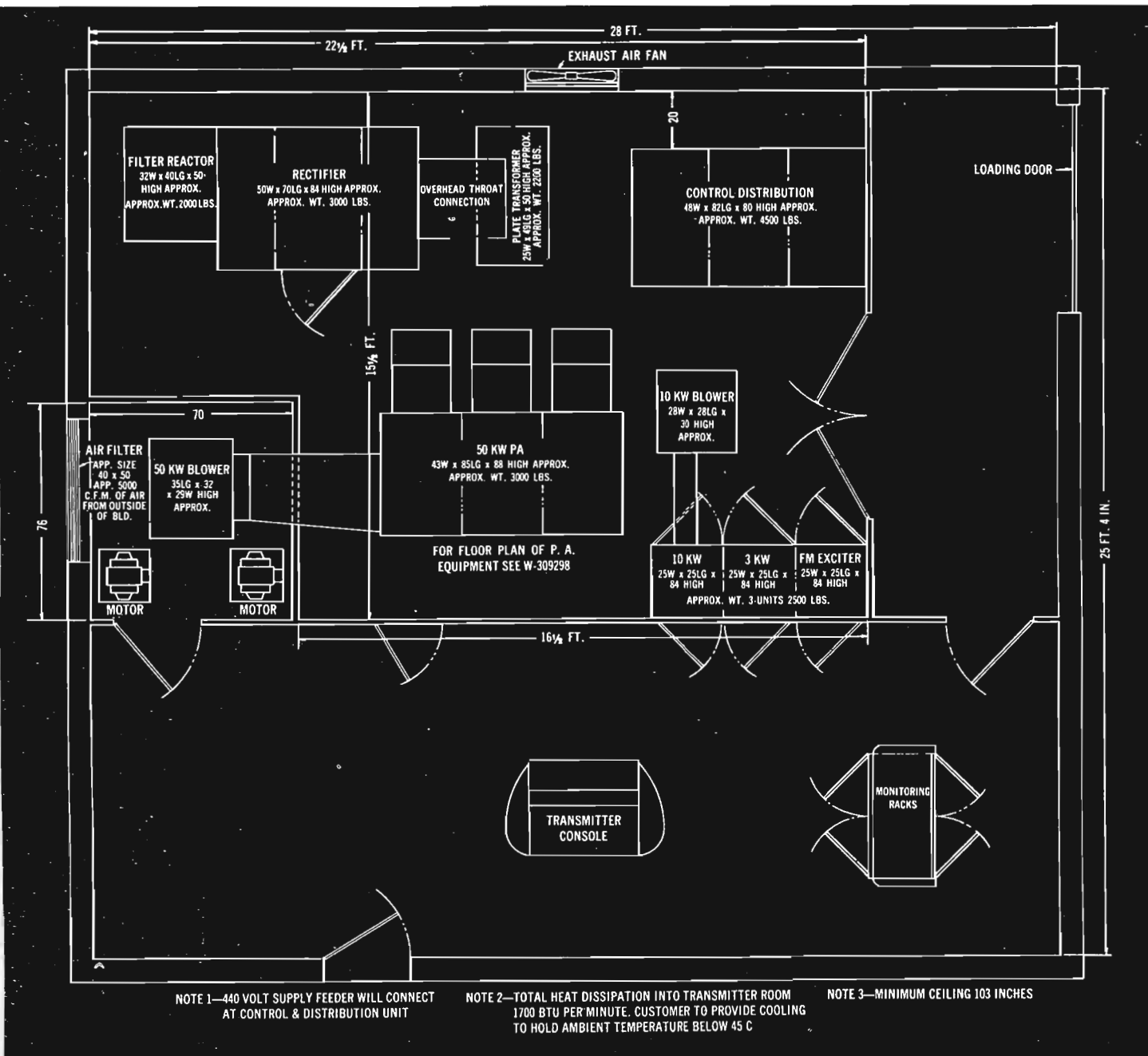

FIG. 2 (above). The final, commercial design 50 kilowatt FM transmitter as installed at WTMJ-FM, Milwaukee. The unified-front panel is finished in a two-tone umber gray to match companion equipment. In foreground is the BTC-1A supervisory console supplied with the transmitter.

FIG. 3 (at right). This model of the 50 KW FM transmitter made during early design stages shows how the entire BTF-50A equipment may be installed on one floor. Entrance doors (at left) to the H.P. blower room and (at right) to the overall transmitter enclosure provide complete walk-in accessibility.





trol wiring was kept out of the r-f fields, and radar type plumbing was used in the r-f circuit.

The amplifier when completed proved satisfactory in providing stable power with flexibility and ease of adjustment, and in having practically no stray radiation. The stability and lack of the idiosyncrasies commonly associated with high frequency amplifiers were gratifying. Refinements in the tube centered about improved methods to raise seal conductivity and to lower grid inductance between the active grid and the grid terminal. This also resulted in better shielding of the filament from the plate thus eliminating feedback capacity. An overall plate efficiency of 65 per cent was achieved, considering plate input as the input into the driver and both output stages. Tuning was not critical, and the frequency range of 88 to 108 megacycles was covered with no trick gadgets or suppressing circuits.

### Final Design

After preliminary development was completed the commercial transmitter was designed and designated RCA type BTF-50A. The entire transmitter is air cooled. Only two types of high power r-f tubes, 7C24 and 5592 are used in this transmitter both of which are fin-cooled external anode triodes. Both types, having low current density grid and plate glass-to-metal seals, are well adapted for use in grounded grid circuits. Both types employ grid header construction for good cathode-to-plate shielding and low grid inductance. The type 7C24 tubes are operated in cascade to approximately the 7.0 kilowatt level. The type 5592 tube is used from the 7.0 kilowatt to the 50 kilowatt level. Use of grounded-grid circuits with proper control of power gain per stage, permits a remarkably good utilization of tube capability, and at the same time allows the higher power level tubes in each chain to operate under more favorable conditions.

The external anode tubes employ special low impedance concentric line circuits, with the cooling fins of the tube forming part of the line.

The exciter unit includes all the frequency generating, modulating, and fre-

FIG. 4 (above). Suggested station floor plan for installation of the BTF-50A transmitter in a one-floor arrangement. Equipment may also be located at two levels if convenient (see WTMJ-FM, this issue).

FIG. 5 (at left). Closeup of the low-power grounded-grid amplifiers. 1 and 3 KW units are in left cabinet, and 10 KW at right. Note motors provided for easy push-button tuning of all stages.

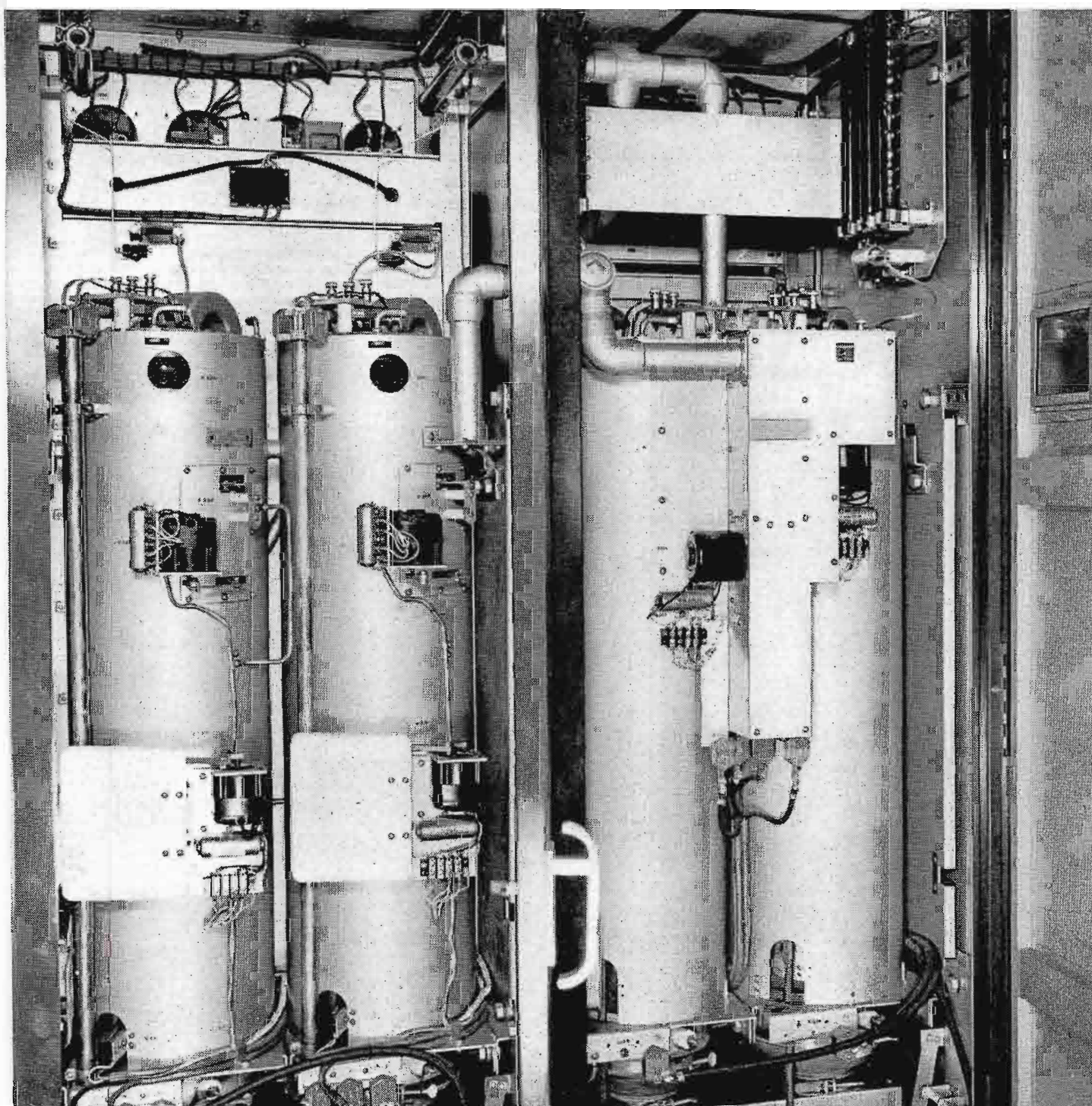

quency multiplying circuits of the transmitter, except the final doubler. The circuit employed provides all the advantages of direct FM plus the frequency stability of crystal control. Center-frequency stability is maintained by electronically comparing the sub-harmonic of the modulated signal with a standard frequency developed by a temperature controlled crystal oscillator. Any difference in frequency actuates a two-phase induction motor which drives a frequency compensating capacitor mounted on its shaft and connected across the tuned circuit of the oscillator. The center frequency is thus held synchronized to a multiple of the standard frequency generated by the crystal and the transmitted frequency is thus held within the frequency limits determined by the crystal.

The exciter drives two conventional grounded-cathode amplifiers using RCA type 4D21 tubes. The first of these amplifiers operates as a frequency doubler, while the second operates as a conventional amplifier. These amplifiers in turn drive two grounded grid amplifiers using RCA type 7C24 tubes. Driving power for the intermediate power amplifier is obtained from these amplifiers operating in cascade.

The Intermediate Power Amplifier employs two type 7C24 air-cooled tubes operating in parallel in a grounded-grid circuit. The electrical circuit is the same as that used in the previous type 7C24 amplifier stages and like these amplifiers employs tuned transmission-line type circuits. Since the grid is grounded for radio-frequency voltages, the driving voltage is applied between ground and filament. A pi type matching network is used with two elements tuned to control driving power. The output of the driving stage is coupled to this network by means of a small coupling loop fed from a concentric transmission line.

Each plate tank is concentric with the anode of the tube and its air cooler and forms the upper end of the inner conductor of the transmission line. Tuning is accomplished by adjusting the position of capacitor-type shorting bars by means of motor-driven screws. Output coupling is effected by small loops properly oriented within the space between the inner and outer conductors of the plate lines. Power output tuning, like input and plate circuit tuning, is controlled from the front panel through a tuning switch and motor.

The 50 KW amplifier incorporates features evolved in the advanced development work previously discussed. It consists of three identical amplifiers, each using an RCA type 5592 tube. The construction of

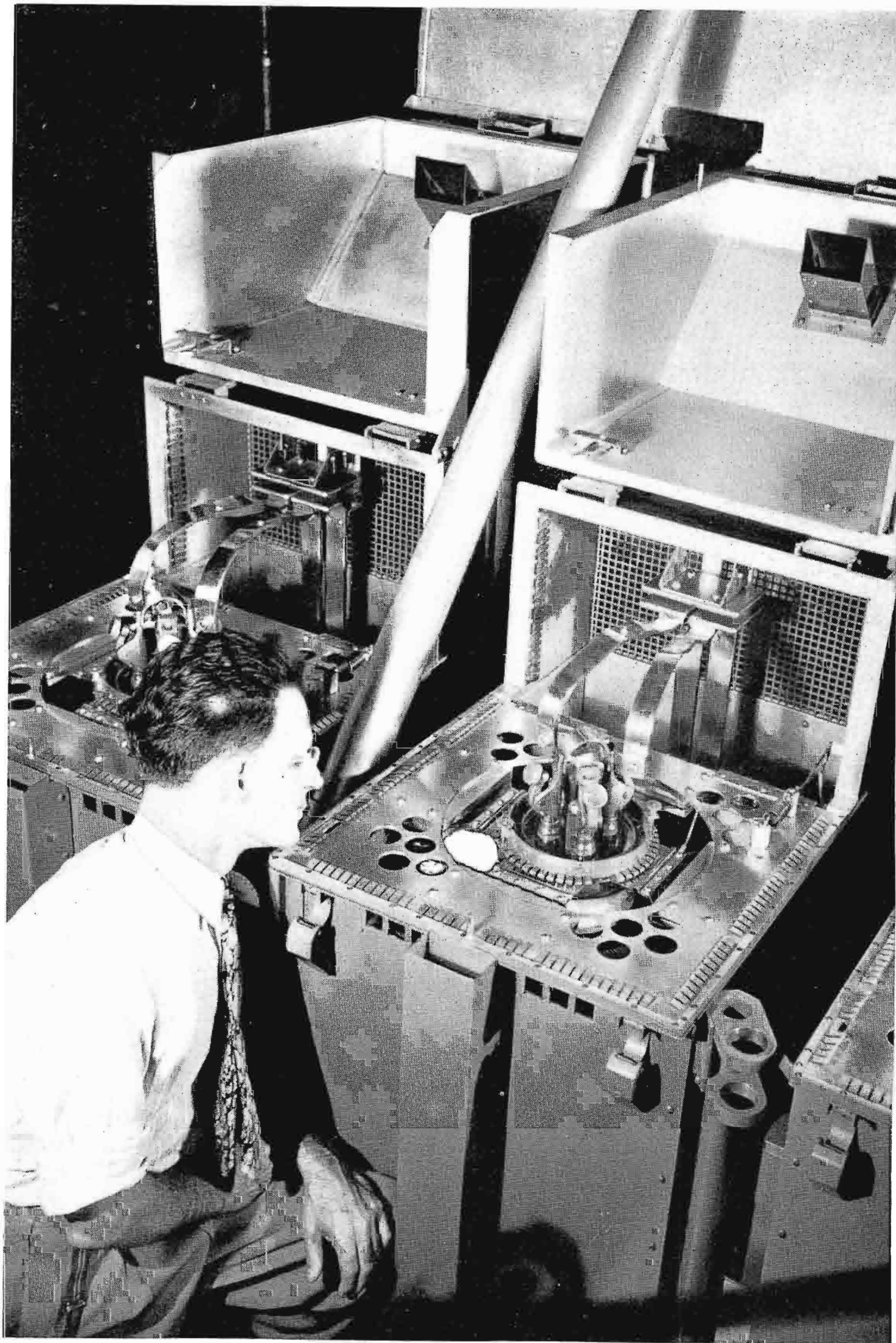
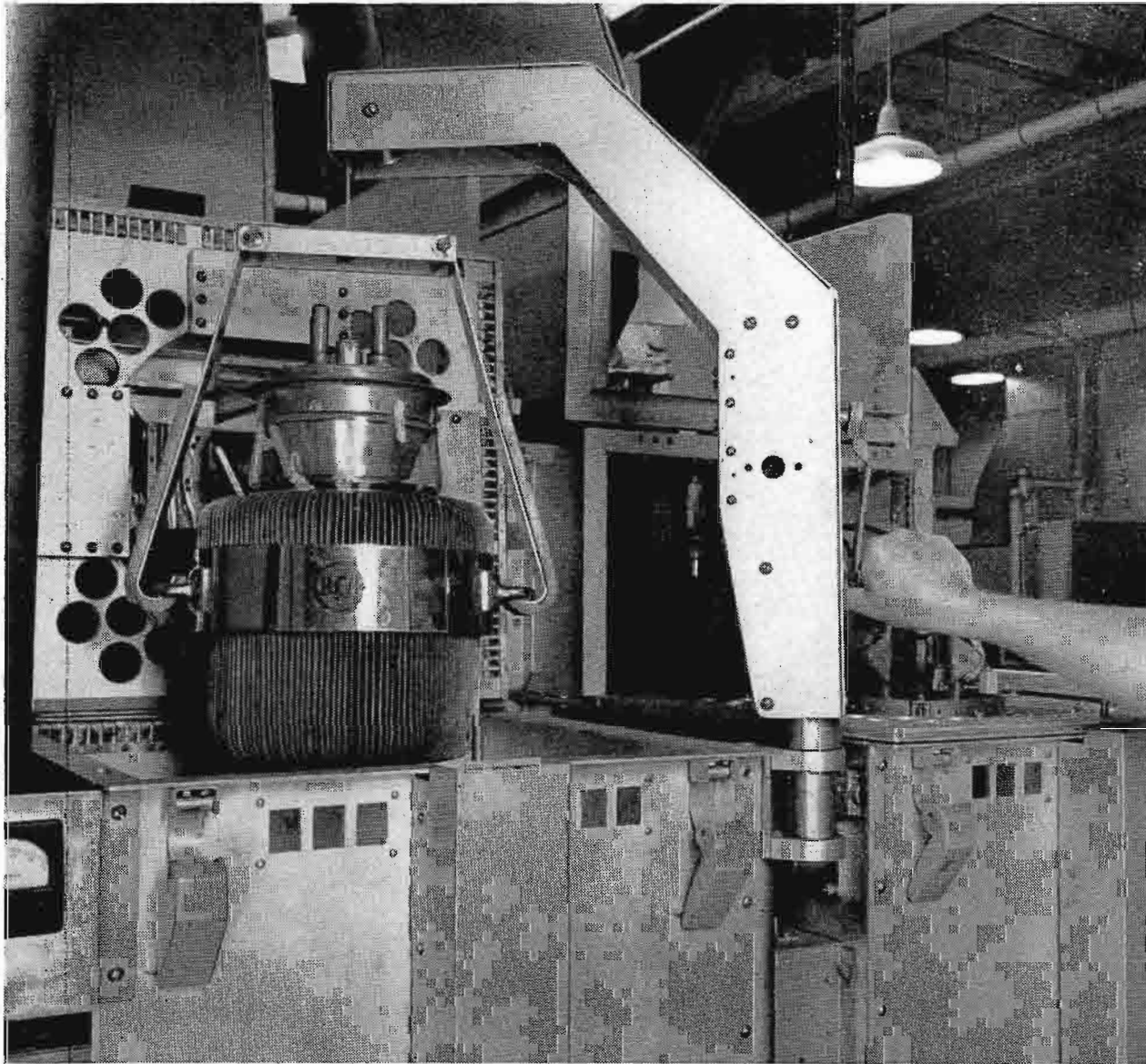

FIG. 6 (above). C. J. Starner inspecting one of the 50 KW FM tank units during engineering tests. The grounded-grid unit at left is the driver, and the two grounded-grid units (parallel-connected) at right form the final amplifier. Each concentric-line tank employs an RCA type 5592 tube. Each unit forms an integral part of the overall circuit. Complete shielding is provided. Neutralizing is not required.



these amplifiers is unusual in that the outer conductor of the concentric plate line tank is square and forms the skeleton of the unit.

Each unit is self-contained, housing all electrical components associated with its operation. The base of the unit forms a plenum chamber for cooling air and contains the control wiring and high voltage bus. The concentric plate line is formed by the frame of the unit and a center conductor mounted on a ceramic socket. The tube in turn is mounted on top of this center conductor and its cooling fins become a part of the conductor.

Plate voltage is fed to the base of the center conductor and the plate choke is the quarter wavelength of bus which connects this point to a de-coupling capacitor.

Tuning of the plate line is accomplished by moving a shorting bar vertically along the center conductor by means of motor

FIG. 7 (at left). The tube hoist shown here is used for easy and quick tube removal, and is supplied as standard BTF-50A equipment. The tube may be raised or lowered by handle visible at right in photo.

FIG. 8 (below). Closeup view of one section of the 50 KW P.A. unit with panel removed to show plate line, "shorting-bar," output coupling loop and balancing meter, as well as tuning indicators.

FIG. 9 (below). Mechanical sketch of a typical BTF-50A amplifier unit, illustrating details of construction and operation. All tuning is push button, motor-controlled from the transmitter front panel.

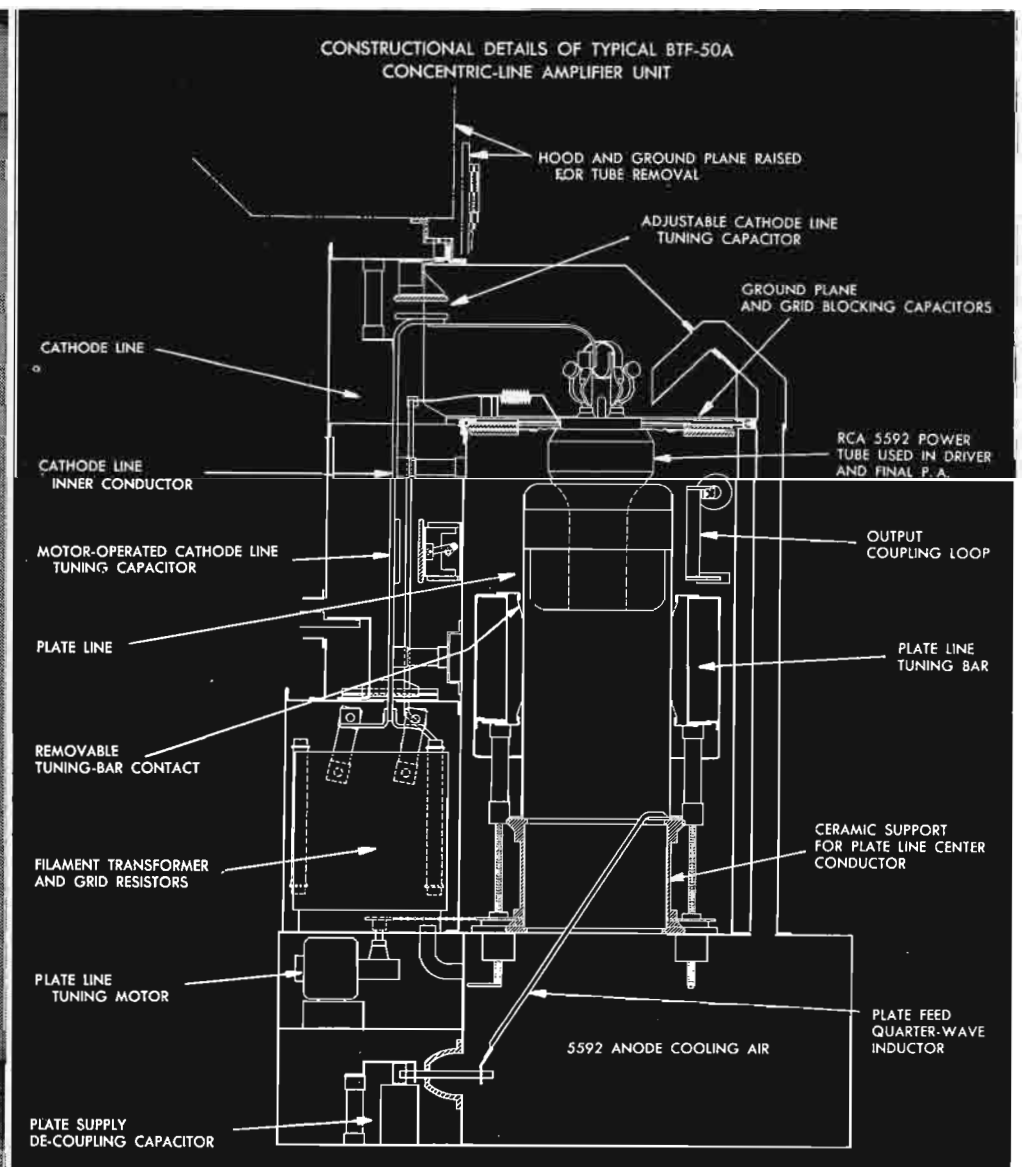
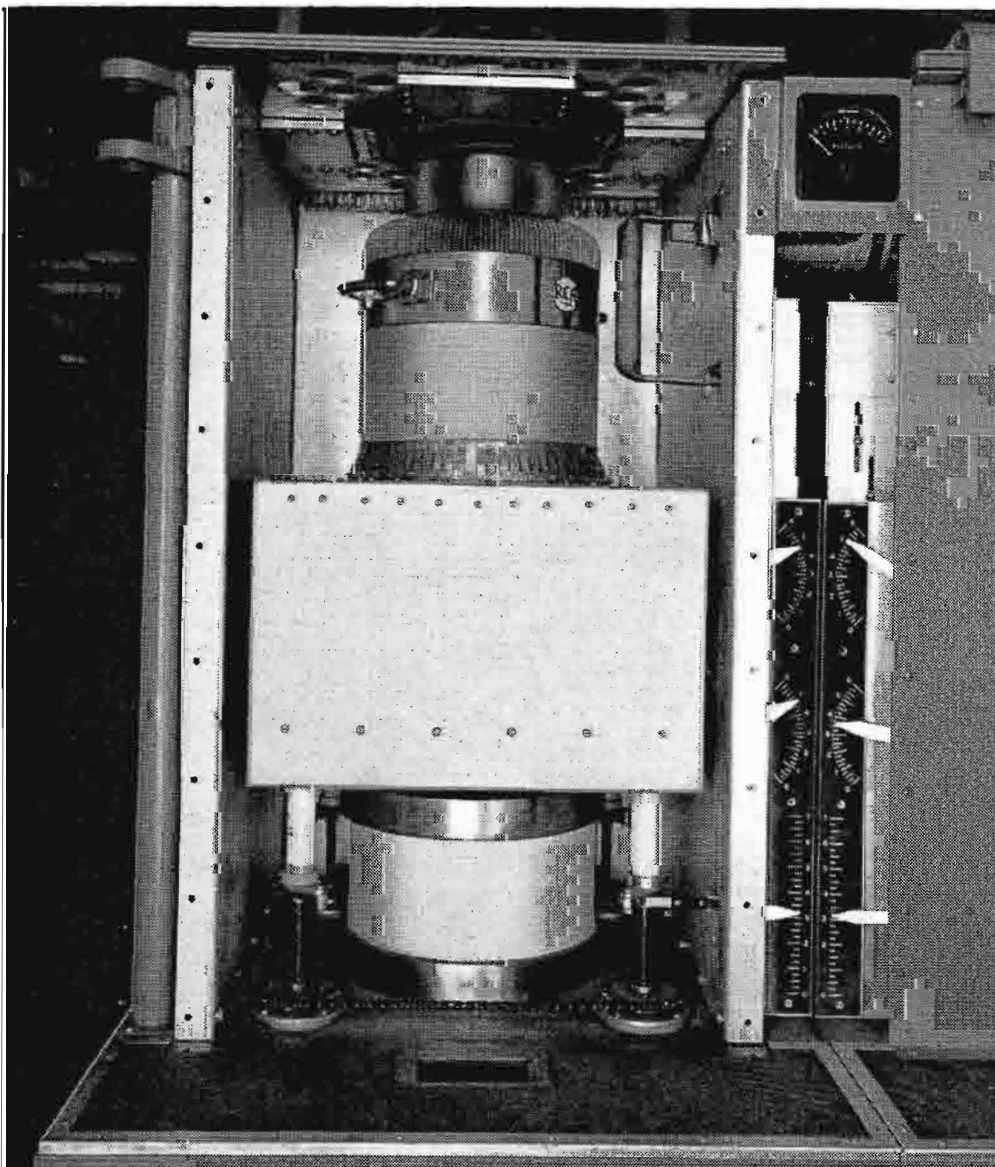

driven lead screws. The shorting bar is fabricated in the form of a box, fourteen inches in length and an inch smaller in width than the space enclosed by the outer conductor of the plate line, with spring contacts engaging the center conductor. This arrangement forms an open line between the surface of the "shorting-bar" and the inner surface of the outer conductor. The capacitive reactance of this line is low enough that the r-f voltage developed across it is of moderate value. It is, however, of sufficient value to materially lengthen the plate line electrically, allowing it to tune to a higher frequency than if direct contact to the outer shell were used. (The converse is, of course, true at low frequencies.) In order to take advantage of this condition at the upper frequency limit and still keep the physical length of the plate line short at the lower frequency limit, the shorting bar is

equipped with two sets of inner contact fingers of which the set at the top of the shorting bar is removable, while the set at the bottom of the bar is permanent. Removing the top set of contact fingers leaves a section of shorted line, next to the inner conductor, of the proper length and characteristic impedance to resonate at 88 megacycles. This method allows tuning of the plate line over the frequency range of 88 to 108 megacycles with a total shorting travel of approximately seven inches. This provides a compact line and helps to keep the amplifier at a convenient height.

The use of a grounded-grid circuit requires as nearly complete shielding between plate or output circuit, and cathode or input circuit as is possible in order to insure stability. At the same time the use of an air-cooled tube calls for clear space around the grid header to allow free passage of air from the cooling fins. To meet

these conflicting requirements the grid blocking capacitor is made in four sections which are symmetrically disposed around the grid connection of the tube, on the plate which forms the ground plane between input and output circuit. A satisfactory compromise between free space and good shielding was effected by breaking the area into small units, leaving no large unshielded area. Each capacitor section is of flat plate construction with mica dielectric of ample size to carry the current required, and with voltage breakdown sufficiently high to withstand gas arc voltages. The total capacity of the four sections is of the right value to insure neutralization.

The physical size of the tube is such that at the top frequency of 108 megacycles the electrical length from active filament to filament terminals is nearly a quarter wavelength. Therefore, a capacity-

FIG. 10 (at right). Rear view of the 50 KW FM amplifier unit showing exhaust ductwork and coaxial lines.

FIG. 11 (below). Closeup rear view of a 50 KW amplifier unit with panels removed to show filament line and capacitors at top, as well as filament transformer and grid resistors below.

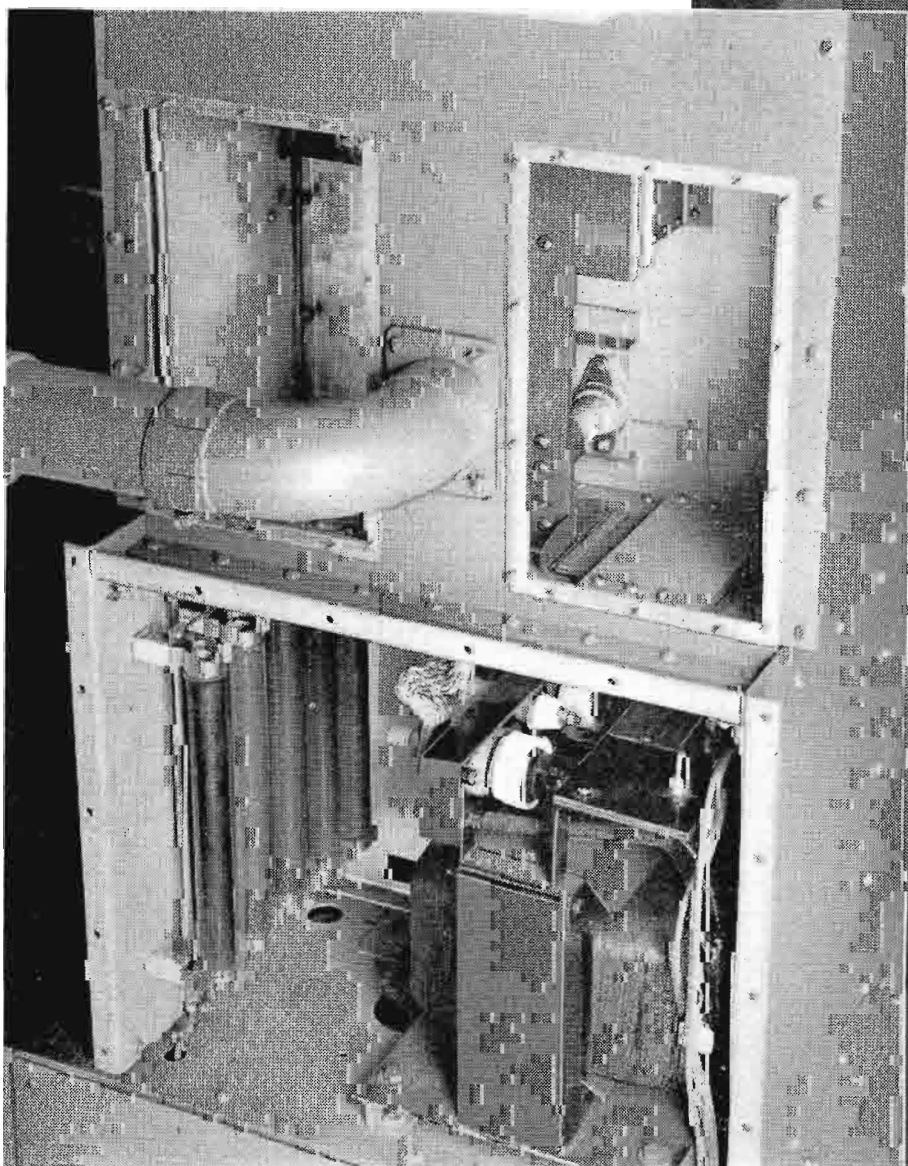
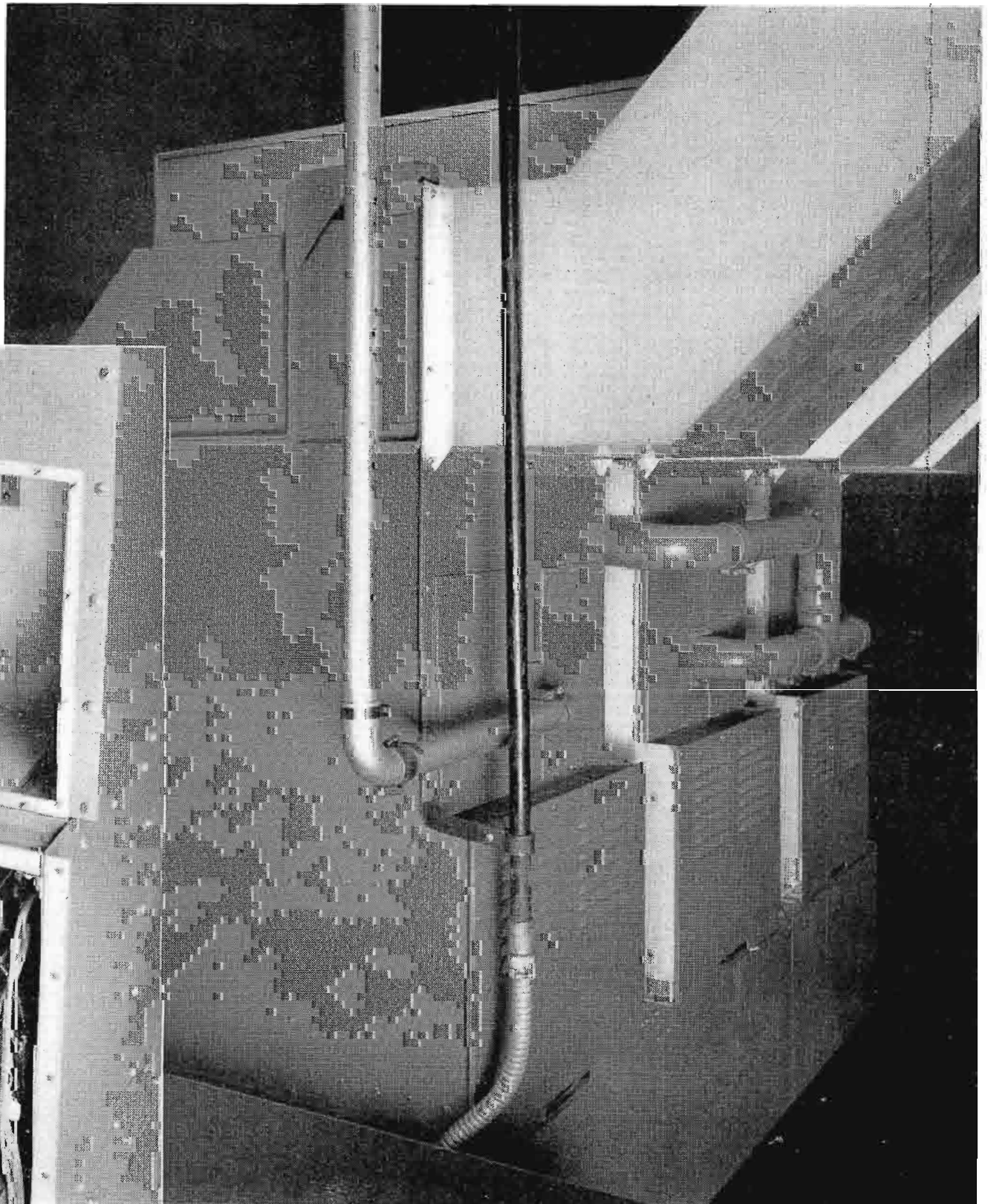

loaded three-quarter wave line, shorted at the input, is used for the filament circuit. This line is formed by the power-frequency filament buses which are folded over and pass down at the back of the plate line.

The input end of the filament line is isolated from ground for direct current and for the power-frequency filament current, but is shorted to ground through two flat plate mica capacitors for r-f frequencies. Tuning through the frequency range is accomplished by the use of two flat plate air-dielectric tuning capacitors, located along the first electrical half-wave from the shorted end of the line. Two capacitors are used in covering the entire frequency range in order to break up harmonic impedances and to enable the use of lower voltage capacitors. Each capacitor is a balanced unit, tuning both filament buses in parallel, with a plate connected to each bus and an associated ground plate. One capacitor is motor driven while the other is manually adjusted.

Coupling r-f energy to the filament line is accomplished through a loop located at the grounded end of the line. Provision is made for matching the impedance of the coupled circuits and in the case of the output stages, for balancing the driving circuit. The entire filament line is shielded

and the filament transformers and grid resistors are placed directly below the line for convenient connection, but are shielded from radio frequencies. Output coupling is motor controlled and is accomplished through the use of a coupling loop with its reactance tuned out by a series capacitor located at the ground end of the loop. This capacitor and the motor mechanism to operate the loop constitute a separate assembly located external to the plate line. A coaxial capacitor is used so that the capacity remains constant when the loop coupling is changed. The loop moves through a 60-degree angle around a vertical axis, giving a wide variation of loading with smooth control.

All r-f fields and currents are confined within shields while the tuning mechanisms and wiring are external to all r-f fields. Spring fingers are used to insure good contacts where panels are not bolted with the result that there is an almost total absence of radiation from the unit.

Tubes may easily be changed by first removing two quick acting snap fasteners. When these fasteners are removed spring loading raises the hood a short distance actuating an interlock switch which removes all plate voltage from the transmitter. Further opening of the hood oper-

ates a positive mechanical grounding switch on the high voltage bus. When the hood has been raised, removal of the filament connectors and the grid connectors, both of which are of a quick acting type, allows the grid separation plate to be raised on hinges to a vertical plane where a snap hook engages it.

Three of the units just described are utilized in the 50 KW amplifier. One unit operates as a driver, and two units operate in parallel as the output stage. The output of the driver is fed to the filament lines of the output stage through coaxial lines arranged so that an equal length of line feeds each of the output amplifiers. Each of the output amplifier filament lines has individual tuning and coupling adjustments to provide drive balance and phasing.

The power from the output stage is fed to a coaxial line transformer section of twenty-four ohms characteristic impedance so that each amplifier feeds a load impedance of approximately fifty ohms. Individual motor driven output coupling provides easy load balancing between the two amplifiers as well as adjustment of power output.

An amplifier balance meter indicates whether the amplifiers feeding the load are equally balanced. A crystal rectifier feeding a d-c meter is connected across a slot located in the center of the outer conductor which interconnects the two output amplifiers. A voltage across this slot is caused by the current flowing from one amplifier to the other and not by the current flowing from each amplifier to the load. The meter will, therefore, register only when the outputs of the amplifiers are unbalanced.

The amplifier tuning controls are located on the front panel. One set of controls operates the driver tuning motors and another set of controls operates the tuning motors of both output amplifiers. A differential key switch designated "balance-tune" switch mounted adjacent to the output-stage tuning controls, allows the tuning motors in the output amplifiers to operate simultaneously in either the same or in opposing directions. Operating both tuning motors in the same direction affords simultaneous tuning of both amplifiers. Operating them in opposing directions balances the amplifiers with practically no effect on the tuning or loading of the output stage.

FIG. 12 (below). View of the blower and motors used for supplying cooling air to the 50 KW driver and final amplifier unit.

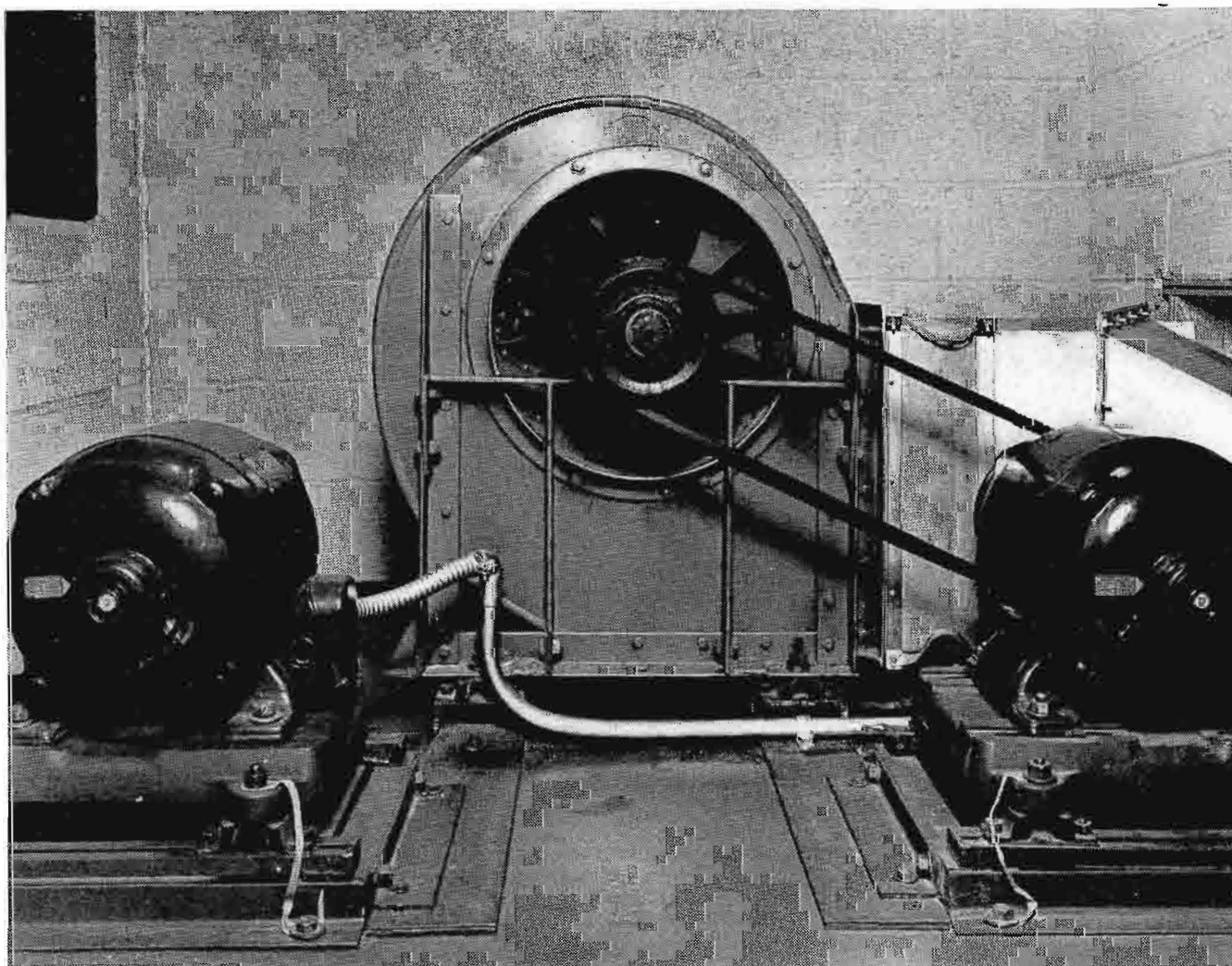



Tuning adjustments are simple and uncritical and absolute stability is obtained under conditions of zero bias, no drive, as well as normal operating conditions.

While the two parallel amplifiers feeding the common load are called the output stage, the driving amplifier contributes materially to the output power. Power gain of the output stage is such that each output amplifier contributes approximately 19 KW to the load while the driver contributes 12 KW. Under these conditions we have a three-tube 50 KW amplifier.

Provision is made for operating the transmitter in emergency at a reduced power of 7.5 kilowatts. In case of failure in the 50 KW amplifier output stage operation of a front panel control switch will automatically shut off the plate power, disconnect the driver and final amplifiers, ground their d-c feed, transfer the antenna from the 50 kilowatt amplifier to the intermediate power amplifier, then reapply plate power to the intermediate power amplifier. At the same time all protective interlocks on the 50 kilowatt amplifier are by-passed, allowing air and filament power to be removed. The 50 kilowatt amplifier and the blower are isolated thus permitting tubes to be changed and servicing to be done while the transmitter is operating at reduced power.

Removal of the plate power from the 50 kilowatt amplifier is accomplished by a double throw single pole contactor of trip-latch type located in the rectifier cabinet. Pilot contacts on this relay in conjunction with interlocks operated by the transmission line switches, give proper sequencing to the transfer operation.

Switching of the antenna from the 50 kilowatt amplifier to the intermediate power amplifier is accomplished by means of new type triple-latch transmission-line switches (see "50-KW FM Power Cutback Switch," this issue, for complete description). The antenna at all times remains mechanically connected to the 50 kilowatt amplifier. Electrical switching is accomplished by using impedance characteristics of a shorted quarter-wave section of a transmission line, with the switches shorting these sections.

One switch is located midway in the line between the output of the intermediate power amplifier stage and the antenna junction box; this line is of the proper length to provide a quarter-wave section

FIG. 13 (at right). Closeup view of the harmonic attenuator and transmission line monitor provided as a part of the transmitter equipment.

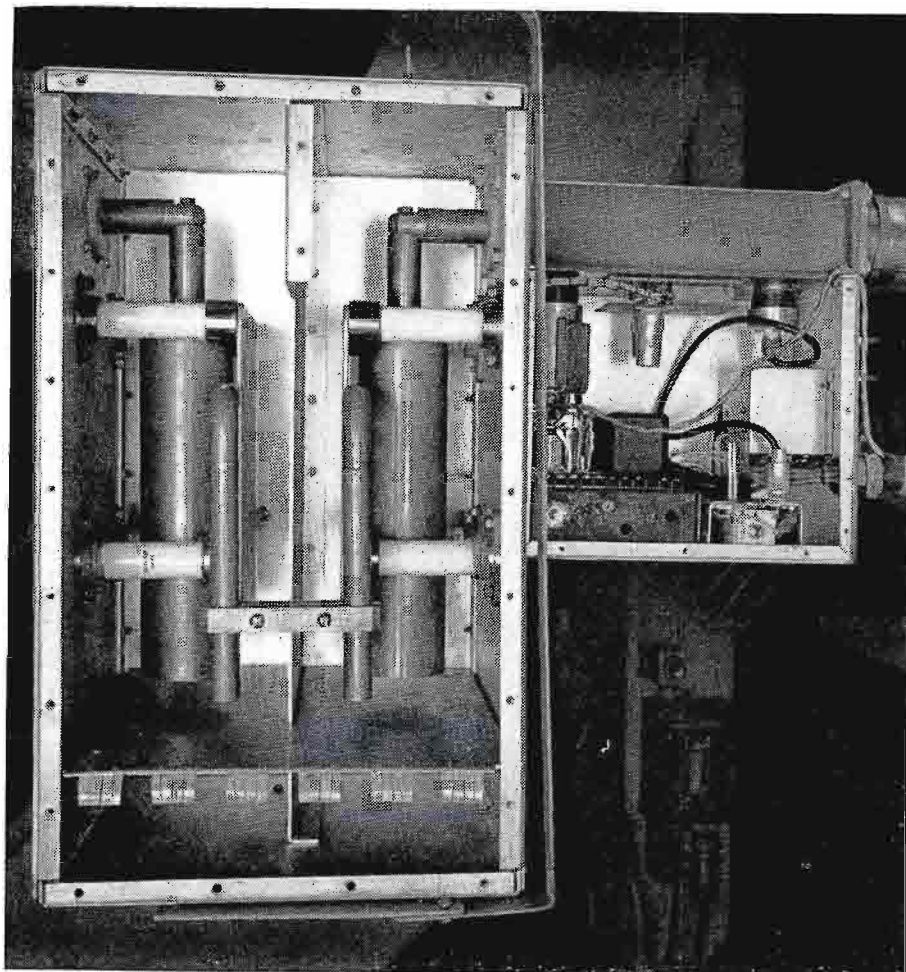

FIG. 14 (below). D. G. Robertson, RCA engineer, illustrates how hinged turret panels of the BTC-1A supervisory console provide complete accessibility. Note that individual meter panel may be tilted back for easy zero adjustments. Transmitter control turret is at left; audio control turret, at right.



on either side of the switch. It is evident that closing this switch will create a high impedance on either the amplifier or the antenna side. A second switch is located a quarter wavelength from the intermediate power amplifier in the line feeding the 50 kilowatt amplifier, while a third switch is located a quarter wavelength from the antenna junction box, in the output line from the 50 kilowatt amplifier. Use of these three switches will connect or isolate the antenna and amplifiers as required.

All plate power to the transmitter is supplied by one rectifier unit using 6 RCA 857-B mercury-vapor tubes connected in a three phase full wave circuit, with a tap to supply the lower power stages. In case a tube fails, a pre-heated spare tube may be manually switched in place of any of the six operating tubes, at the same time

removing the defective tube from the circuit. A reactor input filter is used in the high voltage output with a resistor in series with the filter capacitor to limit peak discharge current to safe values in the event of gas arcs in the output tubes. Filter constants are chosen to limit ripple voltage well below noise level specifications. The center tap filter is in two sections with the output capacitor having a series resistor to limit its peak discharge surge current.

The plate transformer is an air-cooled, natural-draft unit, totally enclosed and arranged for either throat or conduit connection. Primary taps are provided to accommodate line voltages from 440 to 480. An extended winding on the primary provides for tune up voltages of approximately 57 per cent of the full operating voltage.

A harmonic filter and a protective device are provided as a part of the transmitter equipment. Both devices are important to continuous trouble-free operation of the station. The harmonic filter (connected in the transmission line between the transmitter and the antenna) by attenuating all frequencies above the fundamental, insures that other services, operating on higher frequencies will be free of interference even though located close to the transmitter. The protective standing wave detector monitors the antenna transmission line and will cut off the carrier if there is a sudden change in the standing wave ratio such as would result from a transmission line or antenna element arc over.

### High Power FM Installations

Representing the first commercial type 50 KW FM transmitter to be air-tested in early 1947, the BTF-50A is now installed and operating regularly at WBRC-FM in Birmingham, Alabama and WTMJ-FM in Milwaukee (see BROADCAST NEWS, this issue) and WMCF, Memphis.

The RCA 50 KW FM transmitter, type BTF-50A, when used with the RCA eight-section Pylon antenna, enables high-power FM broadcasters to serve primary service areas up to nearly 200 miles in radius, when mountain elevations are used for the high-power, high-gain antenna. Up to 600 KW of effective radiated FM power is possible (see WBRC, this issue) when this combination is employed.

### Performance Specifications

A summary of the performance characteristics for the BTA-50F transmitter is as follows:

- (1) 50,000 watts of radio-frequency power are delivered into an output impedance of 51.5 ohms, with front of panel controlled emergency output of 7500 watts.
- (2) Carrier frequency stability deviation is less than 1000 cycles.
- (3) Audio frequency response is flat within  $\pm 1$  decibel from 30 to 15,000 cycles at all percentages of modulation up to 100 ( $\pm 75$  kilocycle swing).
- (4) Audio frequency distortion is less than 1 per cent, root mean square, from 30 to 15,000 cycles, at 100 per cent modulation ( $\pm 75$  kilocycles).
- (5) FM noise level measured  $-70$  decibel below 100 per cent modulation ( $\pm 75$  kilocycles swing).
- (6) An input power is required of approximately 118 kilowatts from a 3 phase 60 cycle, 460 volt line.

FIG. 15 (below). The high-voltage rectifier employs six long-life 857-B tubes and furnishes plate voltage for entire transmitter. A pre-heated spare which may be switched in place of any one of the operating tubes is provided. Full width door provides walk-in access to all rectifier components.

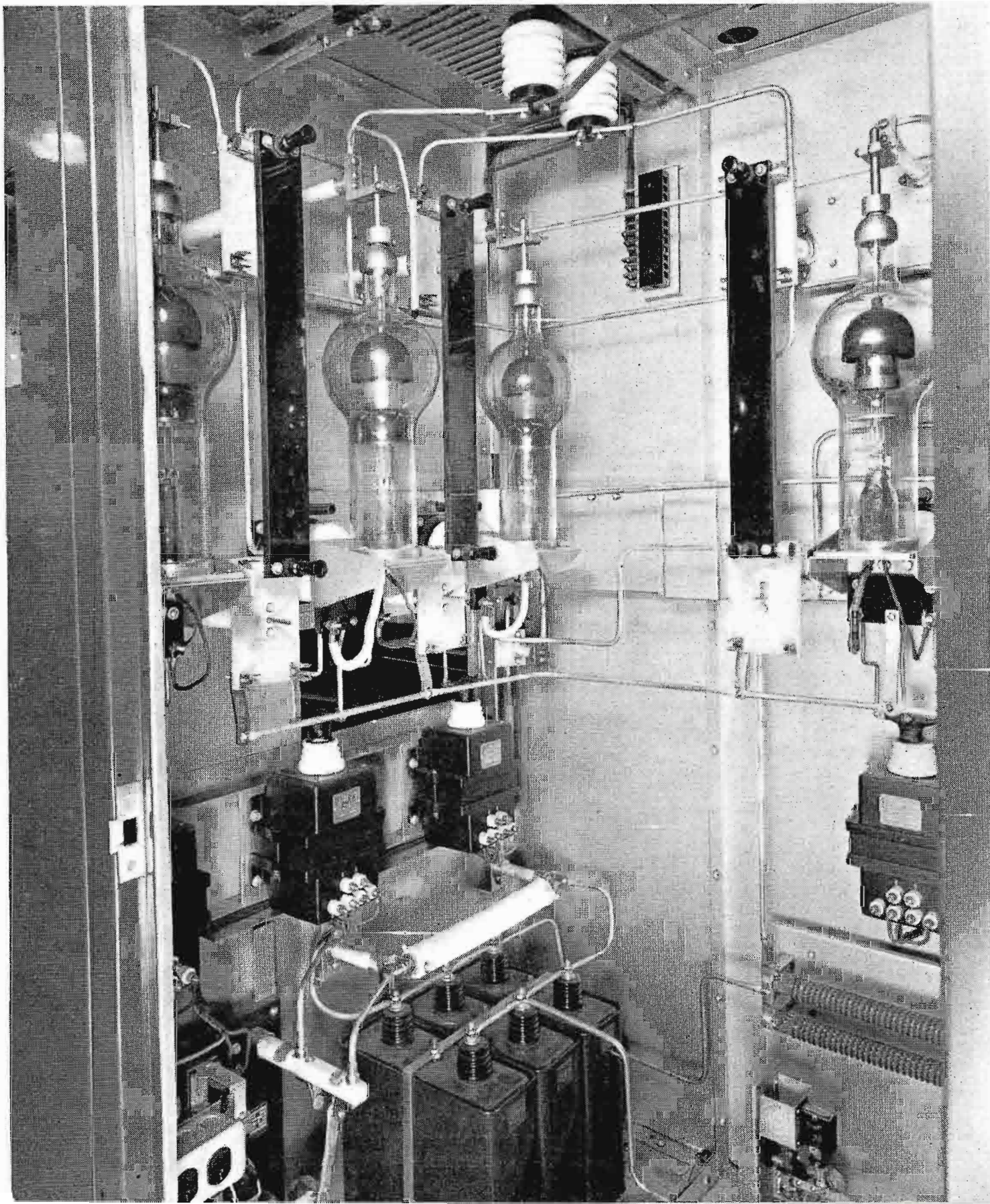

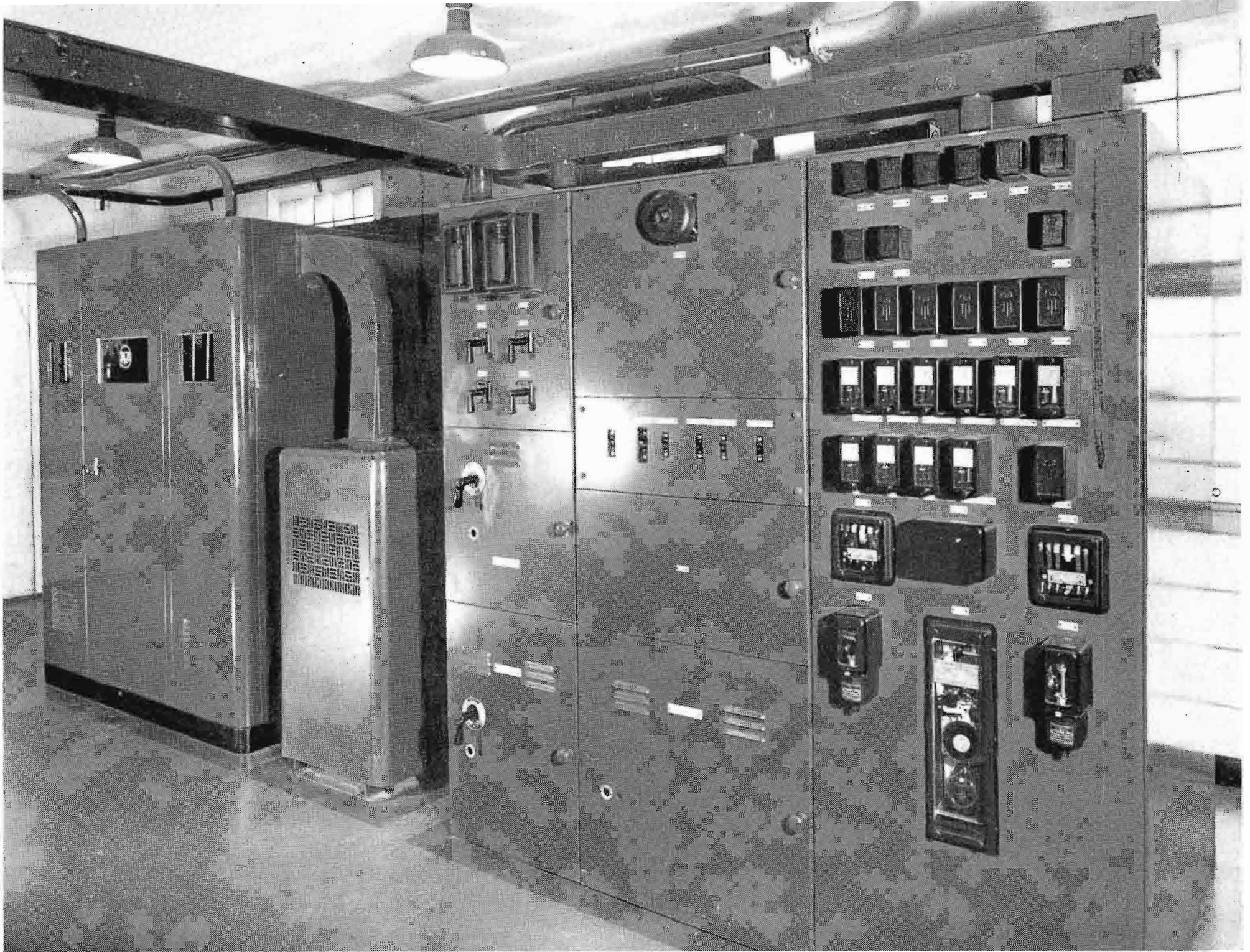
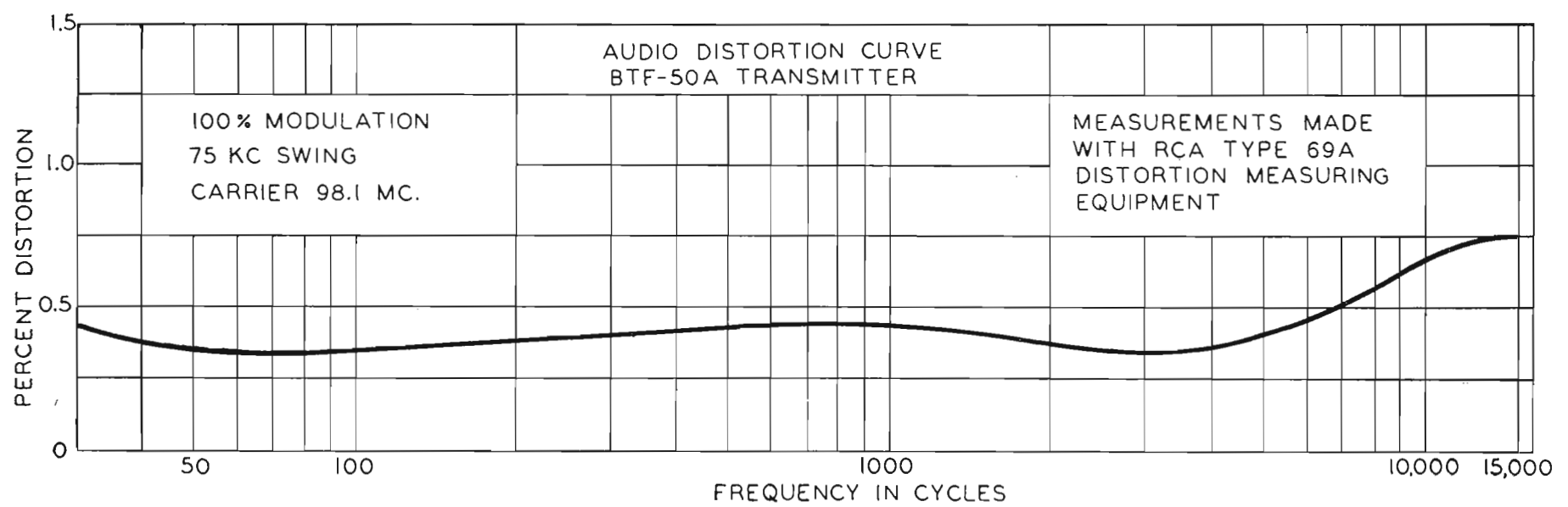
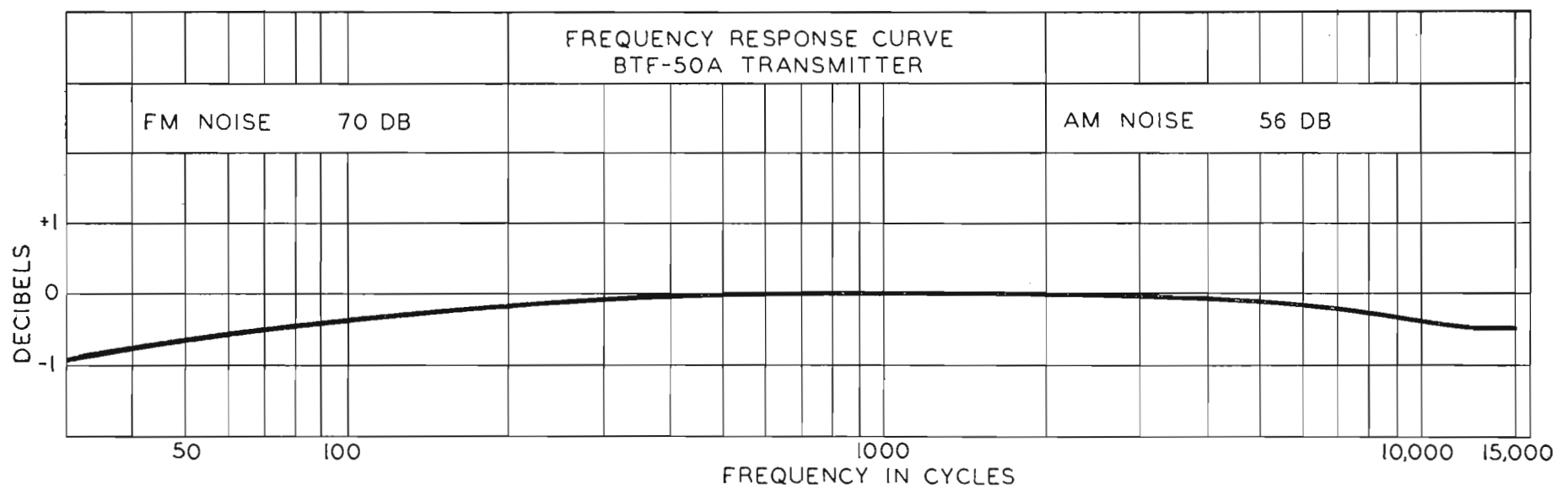

FIG. 16 (above). The complete high-voltage rectifier is housed in the cabinet at left above. At center is the H-V plate transformer; and at right, the transmitter power and control panels.

FIGS. 17 and 18 (below). Frequency Response and Audio Distortion curves plotted from engineering test floor data. Response is flat within  $\pm 1$  db from 30 to 15,000 cycles and distortion less than 0.75%.



# THE 50-KW FM POWER CUTBACK SWITCH

by **C. J. Starner**

Transmitter Engineering Section  
Engineering Products Department

The RCA Transmission line shorting switch fills the need for a means of switching r-f power at high frequencies and high powers in coaxial-type lines while introducing little or no discontinuity in the lines. Standing wave ratios are virtually unchanged by the introduction of the switch in the line and shielding remains complete. Electrical switching is accomplished by using the impedance characteristics of a shorted quarter wave section of line, with the switch furnishing the means of shorting the sections (see diagrams of Figs. 4 and 5). Switches in combinations may be used to perform many types of switching functions, with the assurance that complete isolation or complete connection will occur. Used in a  $3\frac{1}{8}$ -inch coaxial impedance, the switch will handle 50 KW of r-f power at 100 megacycles with a standing wave ratio as high as 2 to 1. Fig. 1 shows the switch inserted in a transmission line, illustrating the self-supporting in line method of clamping on the transmission line. In Fig. 1, the transmission line shorting switch is used in conjunction with the new RCA BTF-50A, 50 KW FM transmitter. Control and interlocking wiring is carried in the conduit

at the bottom of the switch. Two typical switching combinations are shown in the following line diagrams of Figs. 4 and 5.

Fig. 2 is a semi-exploded view of the shorting switch with the mounting flange and dust cover removed, and shows the contact fingers in the closed (shorted) position. Mechanically, the operating mechanism approximates the operation of a conventional camera shutter with the operating power supplied by electrical solenoids.

Operation is of the latch-trip type with the solenoid being used to operate, but not to hold the mechanism. In the position shown here, the left hand solenoid has operated to move the switch to the closed position. Before the solenoid was energized, however, the switch was held in the open position by a positive mechanical latch. When the solenoid is energized and starts its travel, it first disengages this latch and then moves the switch to the open position where a similar mechanical latch again locks the mechanism. Adjustment is provided at the end of both the open and closed travel, to give correct spring tension to the contact fingers on the center conductor and to insure that these contact fingers withdraw to the outer conductor diameter of the line when in the open position. The contact fingers are pivoted on pins and have a slot in the end opposite the contact surface. This slot engages a

pin set on a ring, this ring being rotated by movement of the solenoid as described above.

In the picture of Fig. 2 the pivot point is the smaller (inside) circle of pins, while the actuating pin and slot are the larger (outside) circle of pins. It is apparent then that a slight rotary movement will cause the contact fingers to open and fall back to a larger diameter. The ring upon which the actuating pins are mounted moves with movement of the two ears extending above the solenoids and is thus rotated by linear movement of the solenoids.

Shown in Figs. 2 and 3 is the flange mounting for inserting the switch in a transmission line. Contact to the line is assured by clamping, and contact to the switch body is obtained through the six mounting bases, against which the flange is bolted. An expanding type split connector, not shown in the picture, is used between the center conductors of the incoming and outgoing line, and forms the contact surface for the fingers.

Electrically, we have, in the shorted position, 12 contact fingers, each forming a direct radial connection between inner and outer conductors of the line. Each contact finger is three-eighths inch wide with ample silver contact surface on the inner conductor and with tension contact on both

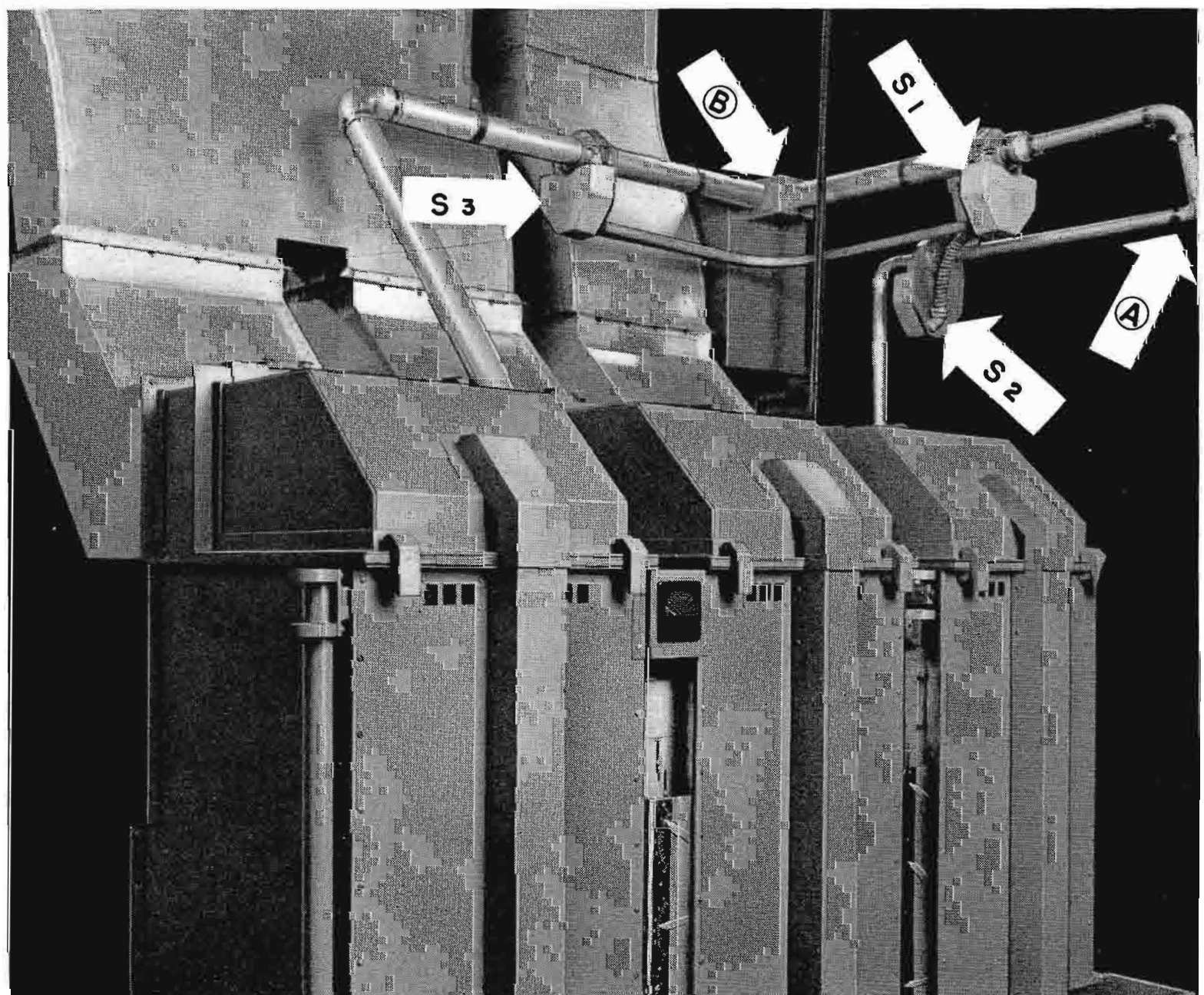

FIG. 1. View of the BTF-50A, 50 KW FM tanks. Arrows (plus diagram of Figs. 4 and 5) show how the transmission line switch impedance arrangement is used to effect instantaneous power cutback, when desired.

FIG. 2 (at right). Closeup of the transmission line shorting switch with cover removed. Note that contact fingers are in the "closed" position.

the pivot point and the actuating pin surface insuring positive contact to the outer conductor.

Fig. 3 shows the switch in the open position. Note that the mechanism has rotated and that the solenoid positions are reversed, causing the contact fingers to open and fall back to the diameter of the outer conductor of the line. The switch, electrically, is now, as far as the transmission line is concerned, non-existent. It should be noted that, strictly speaking, a very slight amount of inductance has been added to the line, due to the enlargement of the outer conductor for the length of the switch mechanism. This length is short and at frequencies in the order of a hundred megacycles there is virtually no discontinuity.

Interlock switches are mounted on the rear (not visible) of switches and are protected by covers. Two interlock switches are provided to monitor the travel in both the closed and open position. These interlock switches are operated by movement of the latching mechanism, and assure not only that the switch has operated to the desired condition, but that the latch mechanism has operated and locked the switch in the desired position.

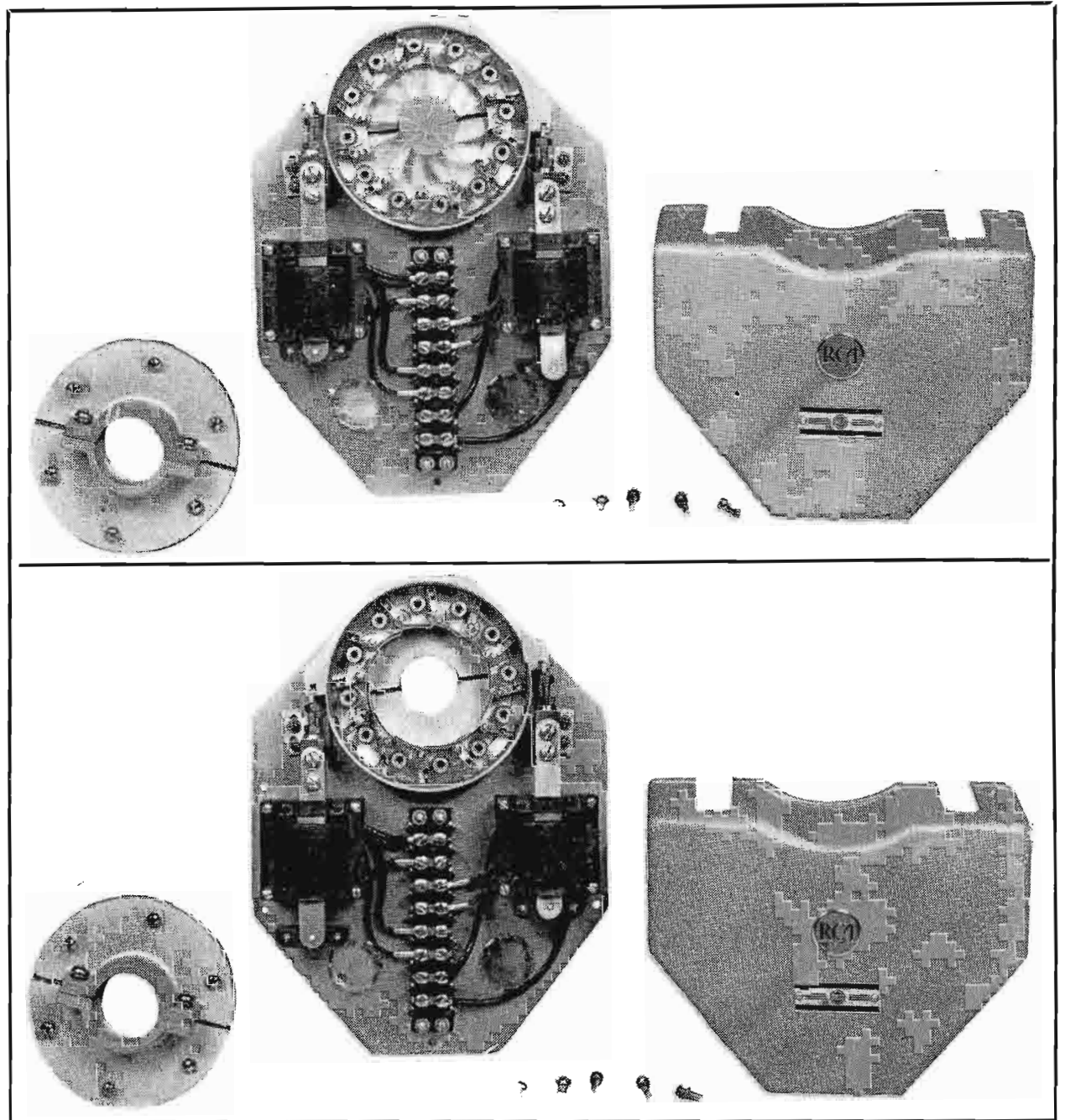

FIG. 3 (above). View of the shorting switch in the "open" position. Mounting flange is shown at left and protective cover at right.

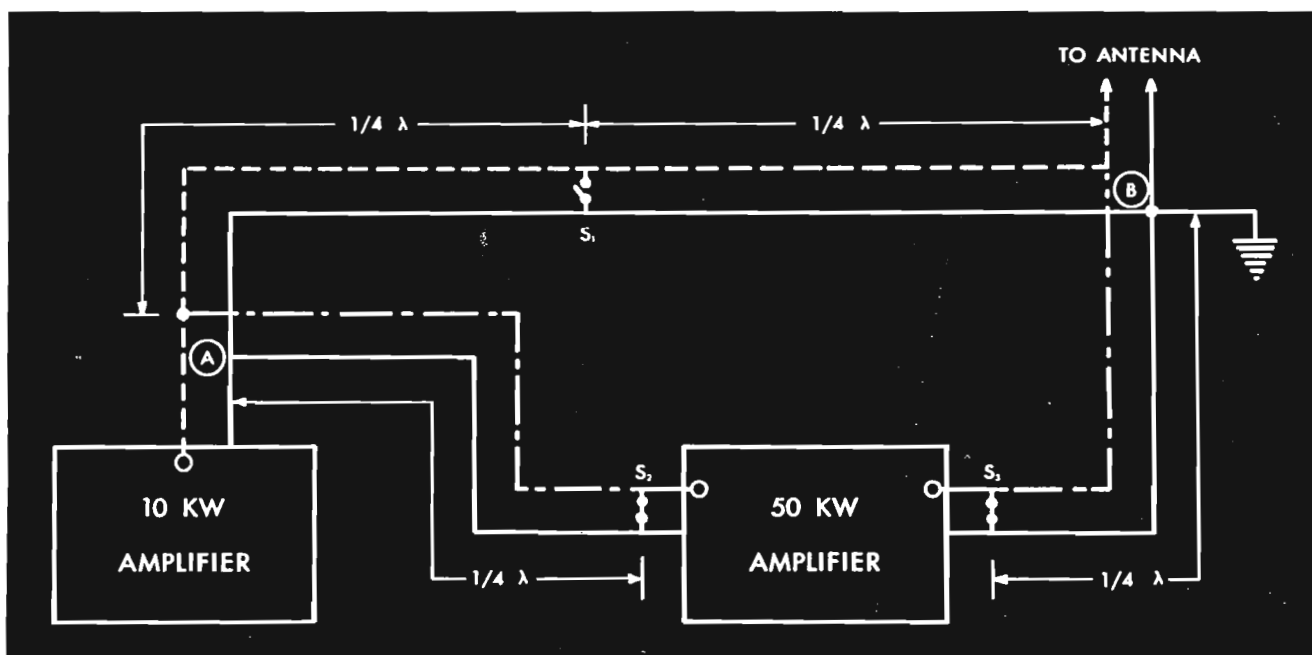
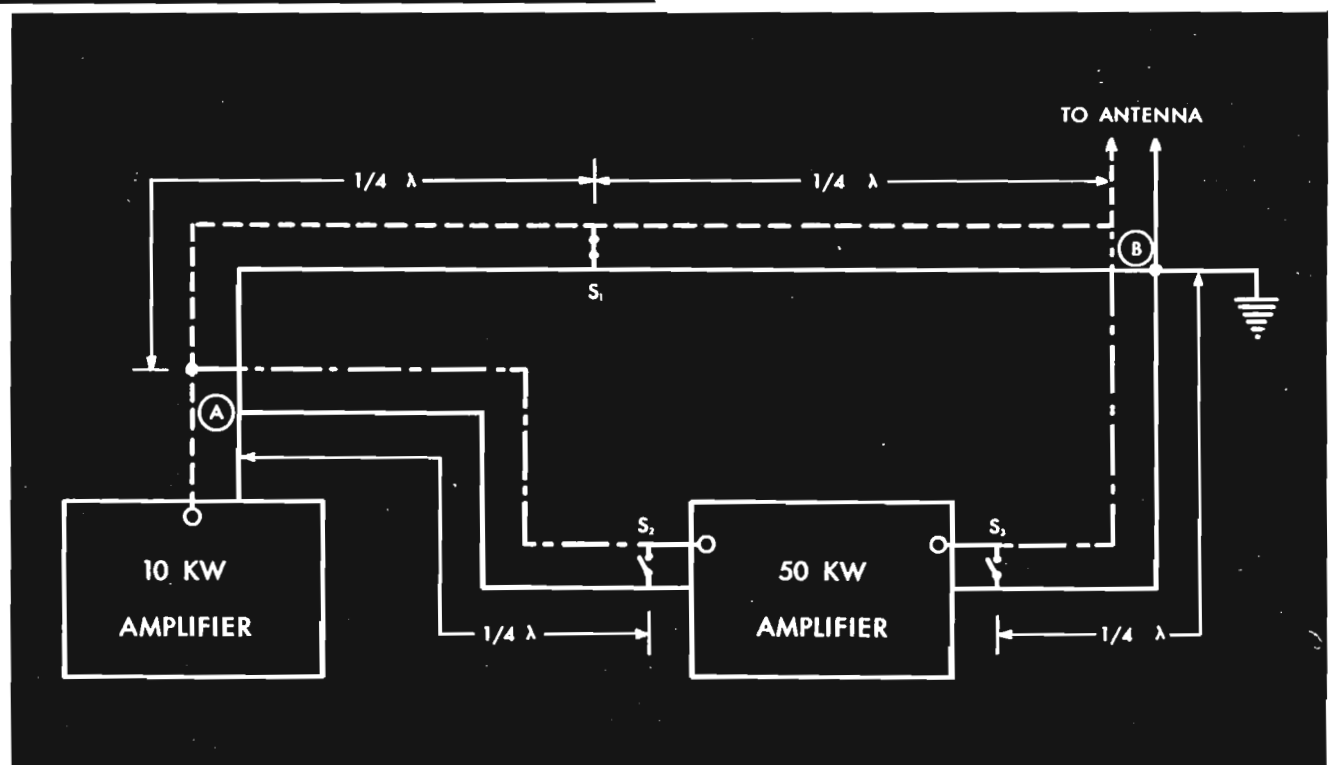

FIG. 4 (at left). Low-Power Operation . . . For emergency operation (at low power) switch  $S_1$  is open, allowing power to be fed (through the dotted line) from the 10 KW amplifier directly to the antenna. Switches  $S_2$  and  $S_3$  are closed, effectively shorting the input and output of the 50 KW amplifier. Because  $S_2$  is a quarter wave from A it reflects infinite impedance at that point and hence does not affect the output of the 10 KW amplifier. Similarly,  $S_3$  is a quarter wave from B and therefore does not affect the impedance at that point.

FIG. 5 (at right). High-Power Operation . . . During regular operation (at full power output) switch  $S_1$  is closed and switches  $S_2$  and  $S_3$  are open.  $S_1$  shorts the direct line between the 10 KW amplifier and the antenna (dotted) and causes the output of the 10 KW amplifier to be fed to the input of the 50 KW amplifier. The output of the 50 KW amplifier feeds the antenna through the line indicated (in long dashes).  $S_1$ , being a quarter wave from point A and B, reflects infinite impedance at these points and hence does not affect normal operation.



# WTMJ-FM...WORLD'S FIRST "Super-Power" FM

By **PHILLIP B. LAESER**

Chief Engineer

FM and Television Facilities

**WTMJ-FM**, formerly W55M, was one of the pioneer FM stations to begin operating in January of 1940 and was the first station to take the air west of the Alleghenies utilizing this improved system of FM broadcasting. On September 18, 1948, WTMJ-FM, owned and operated by the Milwaukee Journal, began regular operation of the first high-band super-power FM station in the nation. An effective power of 349 KW was radiated from the antenna system located some one thousand feet in elevation above the city of Milwaukee. The transmitter used was the newly-developed RCA BTF-50A, 50 KW FM transmitter. An eight-element antenna located on top of a 550-foot tower is used as the radiating system.

With this power, WTMJ-FM is able to give the finest FM service to its listeners within a radius of 105 miles, which corresponds to the twenty micro-volt contour. Signal strengths in the order of twenty-five to thirty thousand micro-volts are obtainable over practically the entire metropolitan area of the city of Milwaukee. Pri-

mary coverage, within the one thousand micro-volt contour, is given to the four largest cities in the state of Wisconsin, namely Milwaukee, Madison, Racine and Kenosha.

The RCA 50 KW transmitter is located in a building atop Richfield Hill which is about twenty-one miles from the downtown metropolitan district of the city of Milwaukee. Richfield, Wisconsin is directly northwest of Milwaukee proper and about fifteen miles inland from Lake Michigan. If WTMJ-FM were located in Milwaukee proper, some forty to fifty percent of the area served would be over the waters of Lake Michigan proper. By locating the transmitter fifteen miles inland a land area of 18,000 square miles is being served. The population served, according to the 1940 census, is an estimated 2,432,000 people.

## Antenna System

The antenna system at WTMJ-FM consists of a Blaw-Knox, Type H-40, self-supporting, heavy-duty, 550-foot tower. The tower has a base spread of approxi-

mately seventy-one feet between the corner legs. One hundred sixty cubic yards of concrete were used in the four tower footings. Mounted on the top is an eight-element antenna bringing the overall height above ground up to 628 feet or approximately one thousand feet over the city of Milwaukee. The antenna system is fed by two 3 $\frac{1}{8}$ -inch co-axial transmission lines using flange couplers. In view of previous experience, it was deemed advisable that the antenna be split using one transmission line to feed the top four elements and the remaining line to feed the bottom four elements. The phasing between the two groups of antennas is accomplished in the transmitter room below. The advantage of this dual system of transmission line lies in the fact that in the event of failure in one of the antennas or transmission line sections, it would be possible to cut out the defective section and continue transmission on the remaining one-half of the system at one-half transmitter power. Under these conditions, only listeners in the outer fringe area would notice a change in the field strength from the station.

## Transmitter Building

The building (see Fig. 1) housing the new WTMJ-FM commercial-type 50 KW FM transmitter is a two floor brick building which is located about 130 feet from the base of the tower. Figs. 4 and 5 show the plan view of the building and transmitter layout including caretaker's room and operators' emergency living quarters. On this floor of the building are located the various units making up the main assembly of the transmitter proper.

## The 50 KW FM Transmitter

Mechanically, the entire transmitter consists of a series of self-supporting sections arranged in line behind a unified front panel (84 inches high x 16 $\frac{1}{2}$  feet long). The direct FM exciter, low power amplifiers (including the 1, 3 and 10 KW grounded-grid stages) and necessary blower are located directly behind the right-hand front panels, as shown in Fig. 10. Doors of the front enclosure allow free access to the driver and power amplifier, r-f cab-

FIG. 1 (below). View of the WTMJ-FM transmitter building. Part of the nearby FM tower structure is also visible.

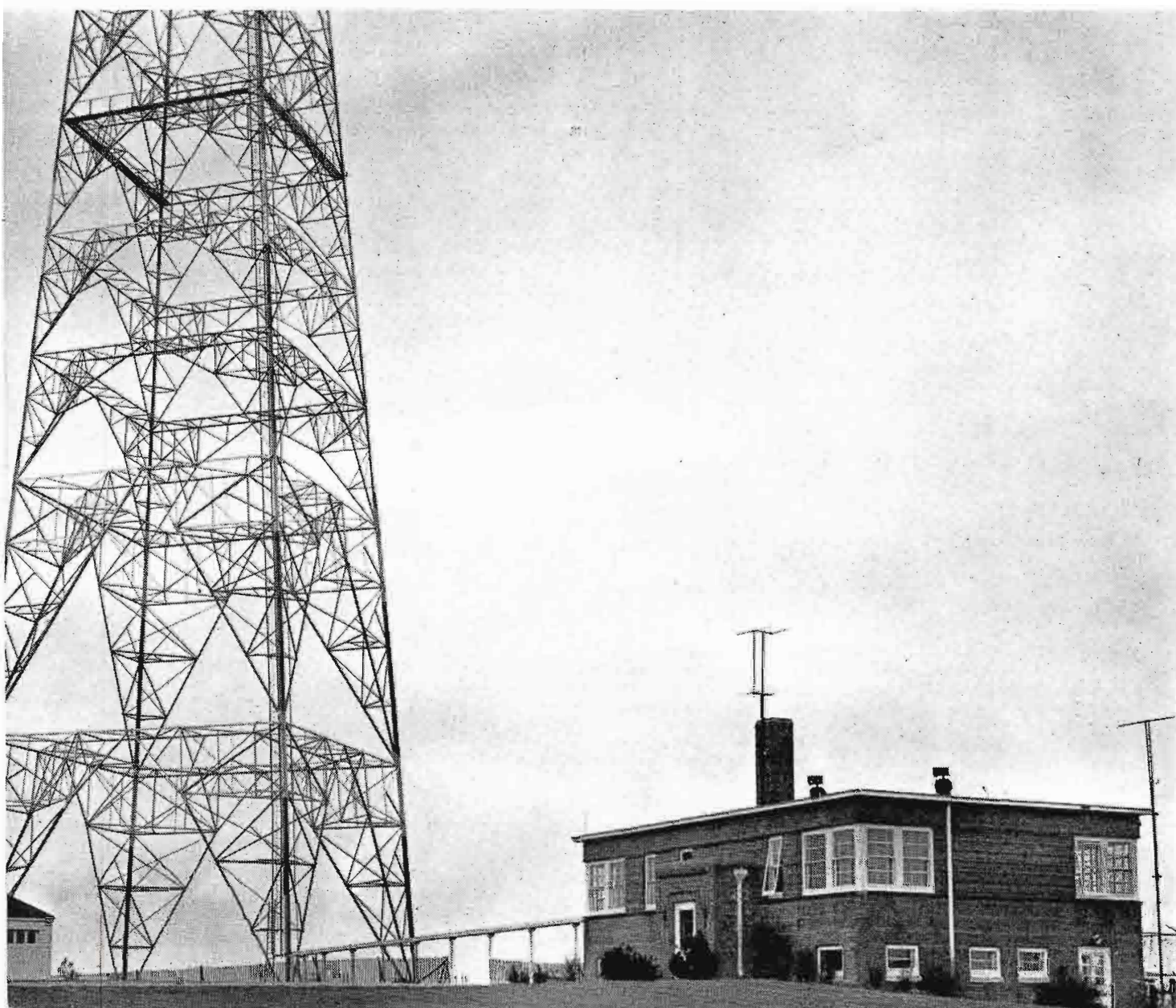



FIG. 2 (above). Phillip B. Laeser, WTMJ chief engineer, observes as W. B. Fletcher, RCA engineer, demonstrates ease of power cut-back to 10 KW from 50 KW operation. All units of the RCA 50 KW FM transmitter are mounted behind a unified front panel providing a neat business-like arrangement with complete accessibility.

CONTOURS OF WTMJ-FM  
RICHFIELD, WISCONSIN

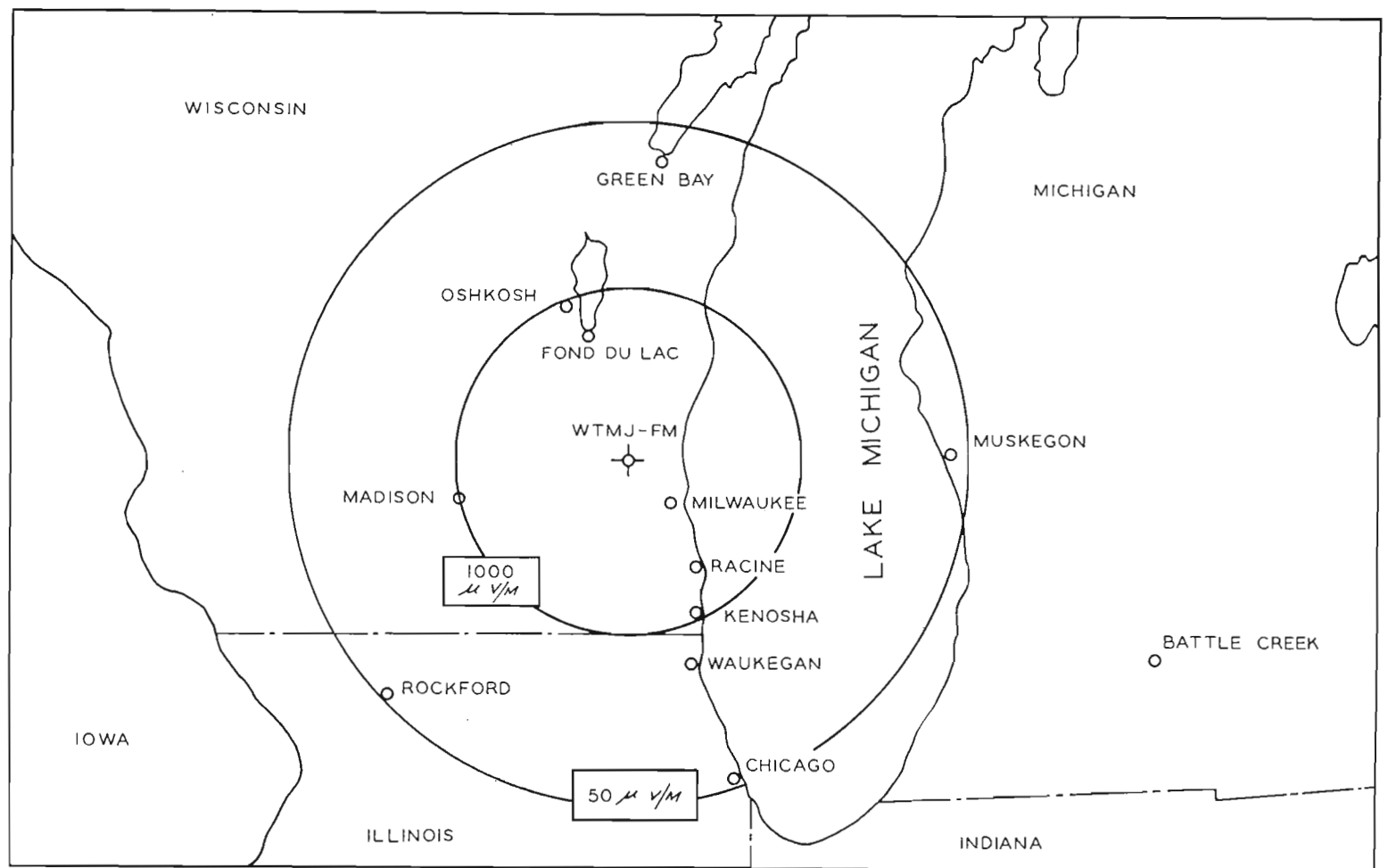
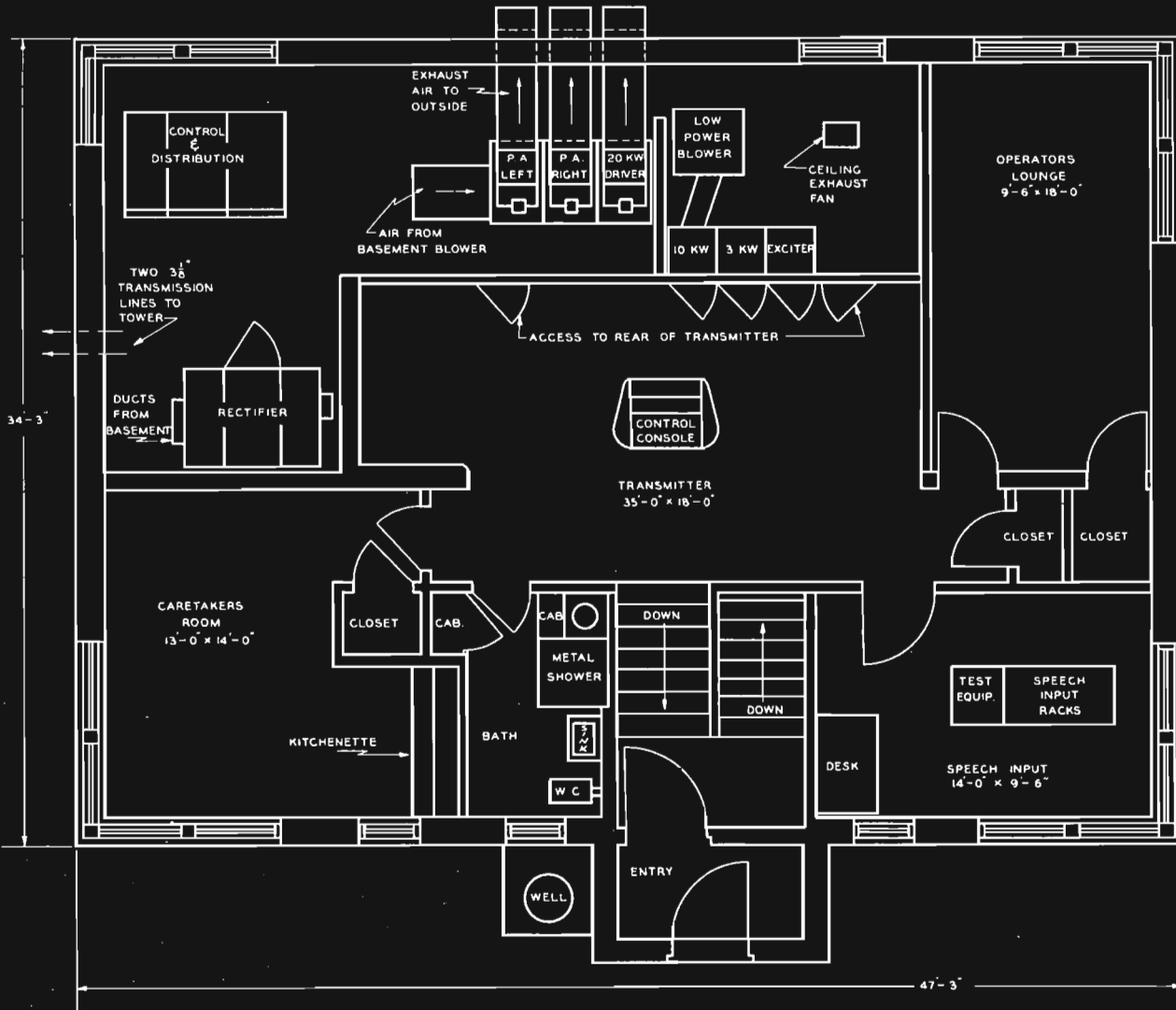
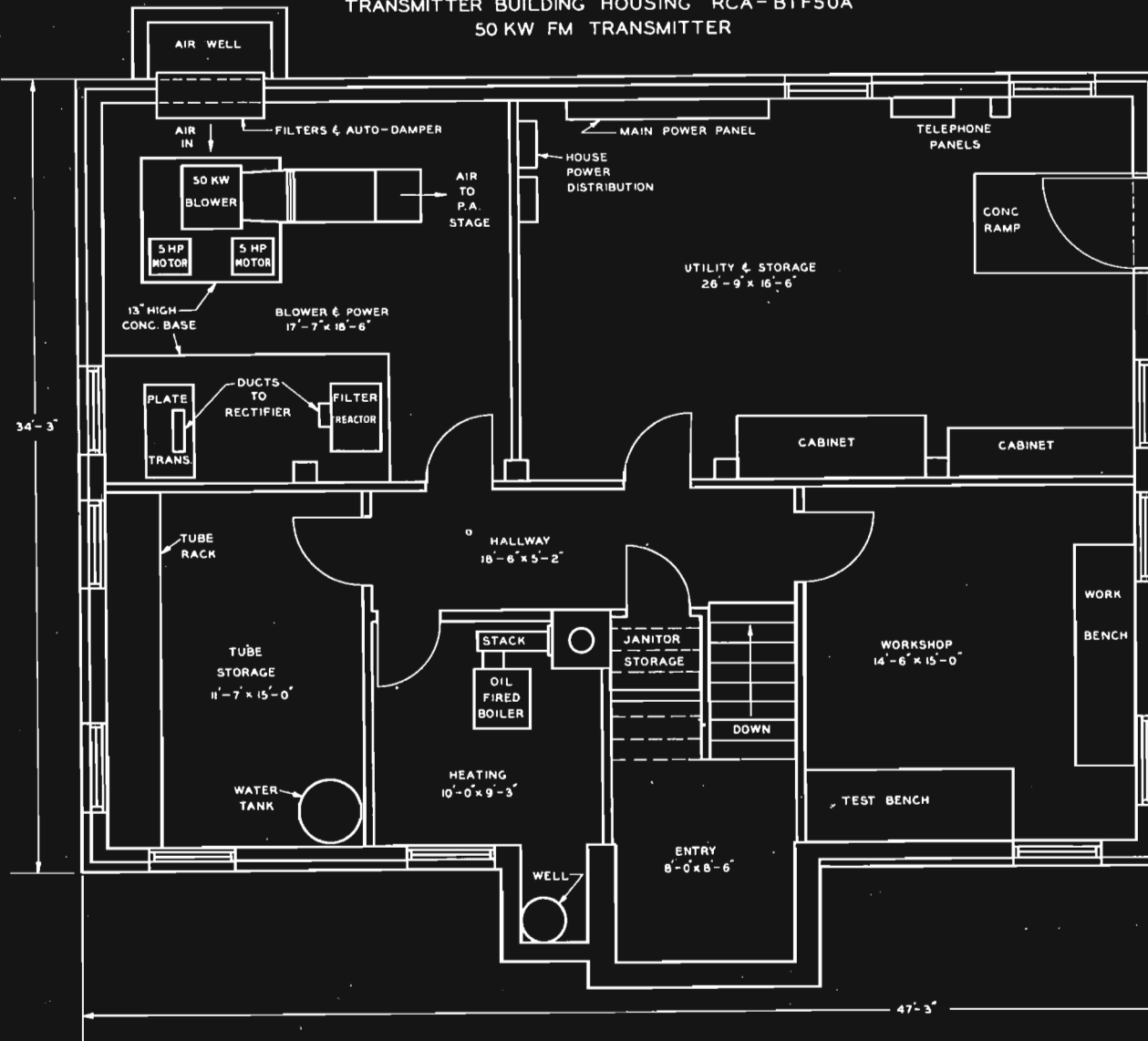

FIG. 3 (at right). As contours of WTMJ-FM show, coverage is extended into parts of three states, Wisconsin, Illinois and Indiana.

1<sup>st</sup> FLOOR PLAN OF WTMJ-FM RICHFIELD, WISCONSIN  
TRANSMITTER BUILDING HOUSING RCA-BTF50A  
50 KW FM TRANSMITTER



BASEMENT PLAN OF WTMJ-FM RICHFIELD, WISCONSIN  
TRANSMITTER BUILDING HOUSING RCA-BTF50A  
50 KW FM TRANSMITTER



inets, and to the entire transmitter enclosure area. To the rear of the left-hand and center control panels are the three power amplifiers which combine to make up the 50 KW power amplifier.

To obtain the necessary 50 KW of power, two 25 KW amplifiers and one 20 KW driver amplifier, each using the newly-developed air-cooled RCA type No. 5592 tubes, are used in grounded-grid circuits. (Fig. 6 shows these amplifiers.) By using grounded-grid amplifiers in all of the power stages, a considerable amount of generated power is fed through the amplifier from each of the preceding driver stages. This is reflected in the output circuit as an apparent increase in the overall efficiency of the amplifier. In the instance of the two final 25 KW amplifiers, which are coupled together to feed the antenna, the efficiency factor under normal grid drive conditions for 50 KW operation is 85 percent.

With typical power readings of  $E_p$  of 7.9 K.V. and  $I_p$  of 7.35 amp. or a power input of 58 KW, we obtain an output of 50 KW. One of the several features of the transmitter is the power cutback equipment consisting of trip-latch transmission line switches which allow instantaneous transfer of the antenna to the 10 KW stage. This operation thereby removes all power from the 50 KW circuits leaving the equipment safe for the personnel to service in the event of equipment failure. Another feature of the transmitter is the reflectometer which is mounted on the transmission line leading to the antenna. This instrument indicates the degree of the reflected energy from the antenna system. In the event of an antenna or transmission line failure causing the reflected energy to increase beyond a predetermined set safe value, the reflectometer in connection with its associated equipment will immediately cut off the transmitter power,

FIG. 4 (at top). First floor plan view of WTMJ-FM transmitter building shows location of 50 KW FM transmitter components. Note that doors provide walk-in access to entire transmitter enclosure.

FIG. 5 (at left). Basement floor plan at WTMJ-FM shows how high-power blower and ducts, plate transformer, filter reactor and ducts to rectifier are installed at basement level due to limited space available on first floor.



thereby safeguarding and protecting the antenna system from burnout.

The 50 KW transmitter supervisory console (furnished with the transmitter) is located in a central position in front of the transmitter proper. This new console is especially designed for use with the RCA 50 KW FM transmitter and contains a transmitter control turret and audio control turret. Thus, complete switching, mixing and control-circuit facilities are provided for greater ease and efficiency of station operation.

The high-voltage rectifier and power-control panels are located directly to the left of the power amplifier. A feature of the new transmitter is the walk-in type construction of the high-voltage rectifier, thus making tube changes and transmitter service comparably simple. In the main rectifier, six RCA 857-B mercury-vapor tubes are connected in a three-phase, full-wave circuit with a half-voltage tap to supply the lower power stages. A pre-heated spare may be manually switched in place of any of the six operating tubes.

Since sufficient room was not available near the high-voltage rectifier for the high-voltage transformer and filter reactor, they were located in the basement directly below. Steel ducts between the units were installed to form a protection for the high voltage leads. Fig. 8 shows the transformers in the basement below. At the basement floor level are located the 440 volt 150 KVA power and switching facilities, blower room, high voltage and filter reactors, spare tube room and building heating equipment. Fig. 5 shows the plan view of this building level. Fig. 7 shows the blower installation. Because of the many developmental and experimental projects that the Milwaukee Journal station has undertaken in the past, there is available to the personnel a fine array of technical instruments and machine tools.

**FIG. 6 (above).** A. B. Van Alstyne, WTMJ-FM transmitter supervisor, using tube hoist to install one of the RCA 5592 P.A. tubes in the power amplifier unit. At right 5592 tube is in place and ready for operation when outer housing cover is closed.

**FIG. 7 (center).** The blower and associated ductwork for the power-amplifier air-cooling is located at the basement level, as shown here.

**FIG. 8 (at right).** Since sufficient floor space was not available near the high-voltage rectifier, the H-V transformer and filter reactor were mounted directly below on a concrete platform at the basement level and connected with ductwork.

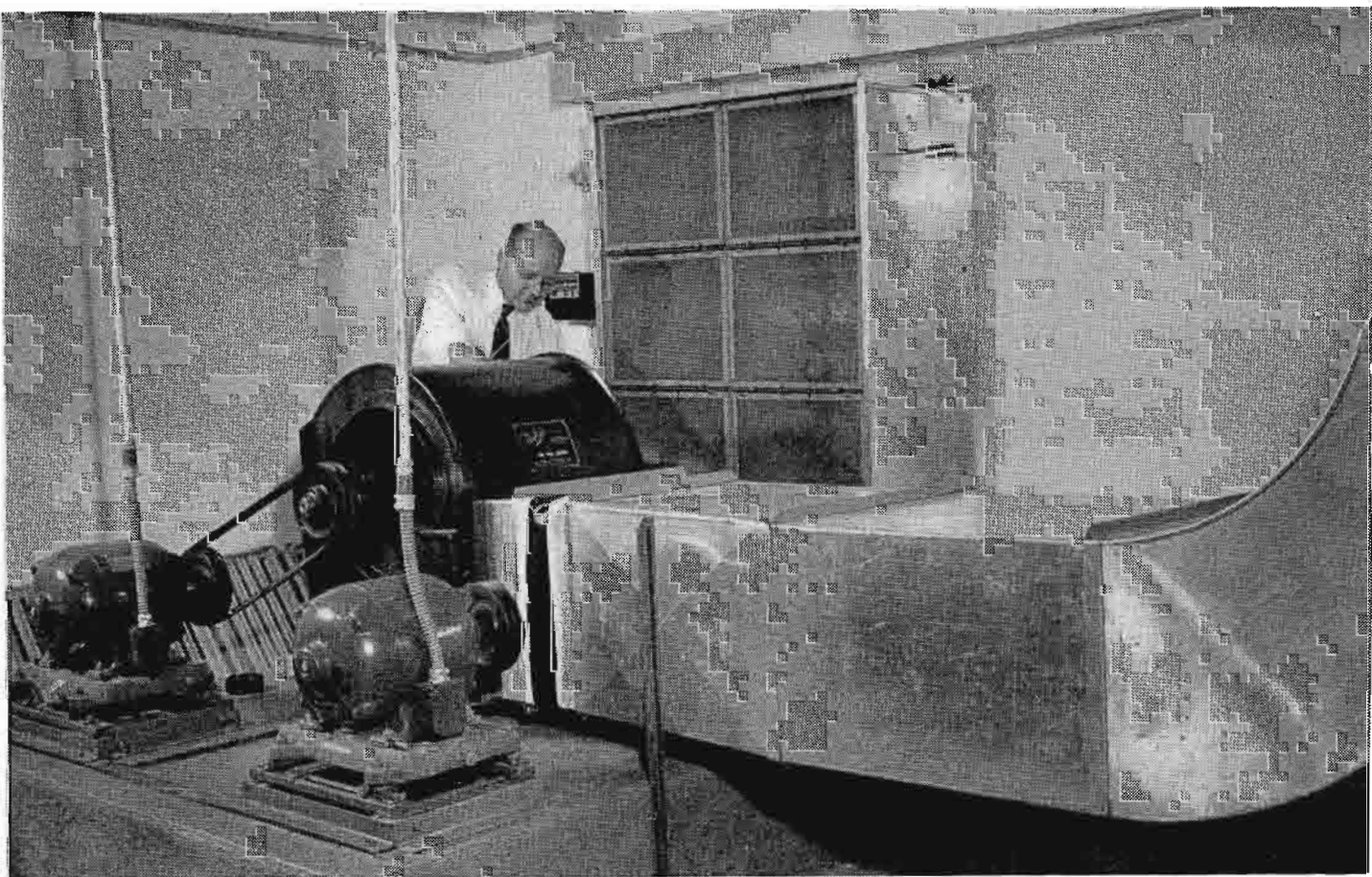
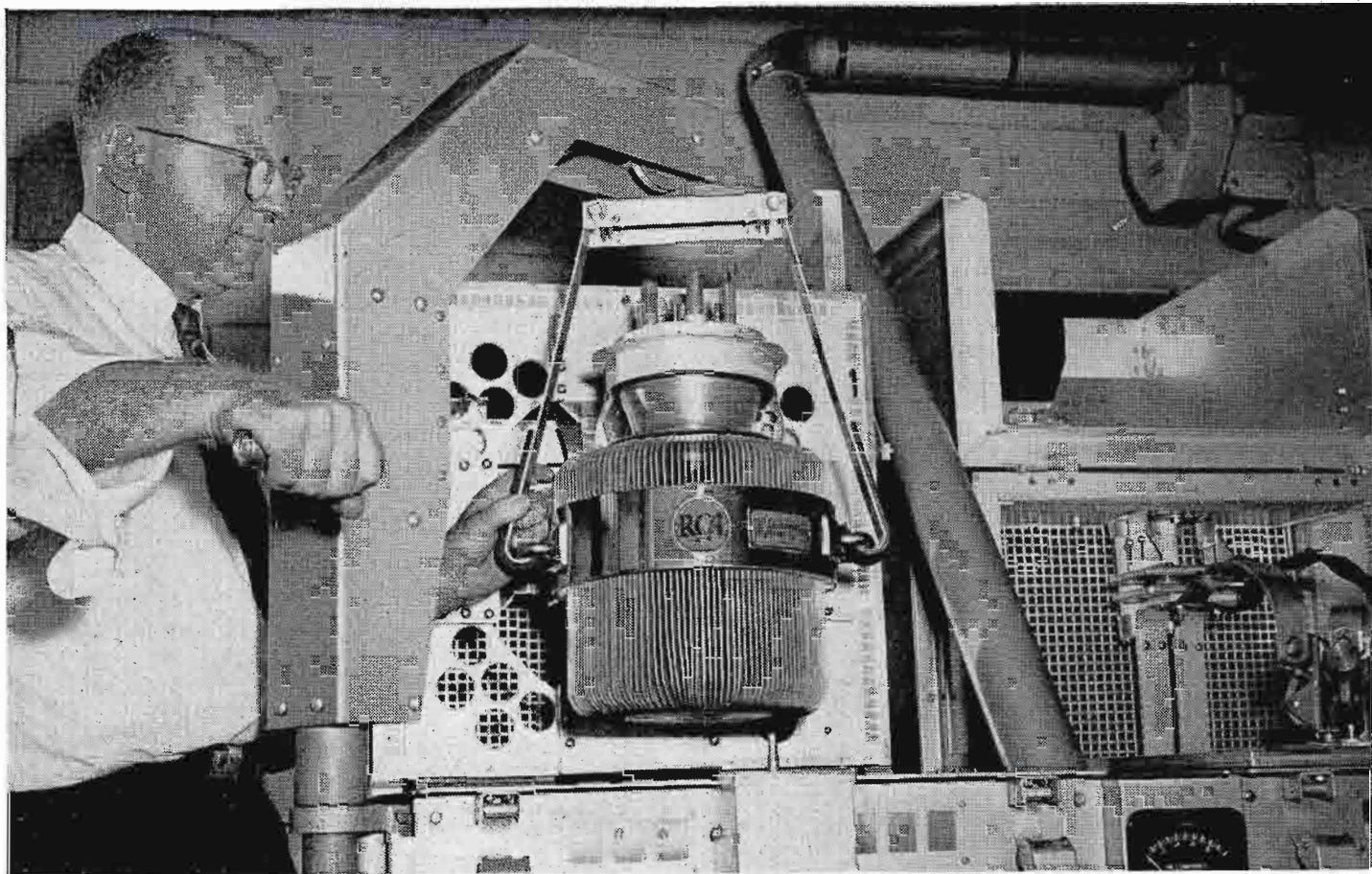

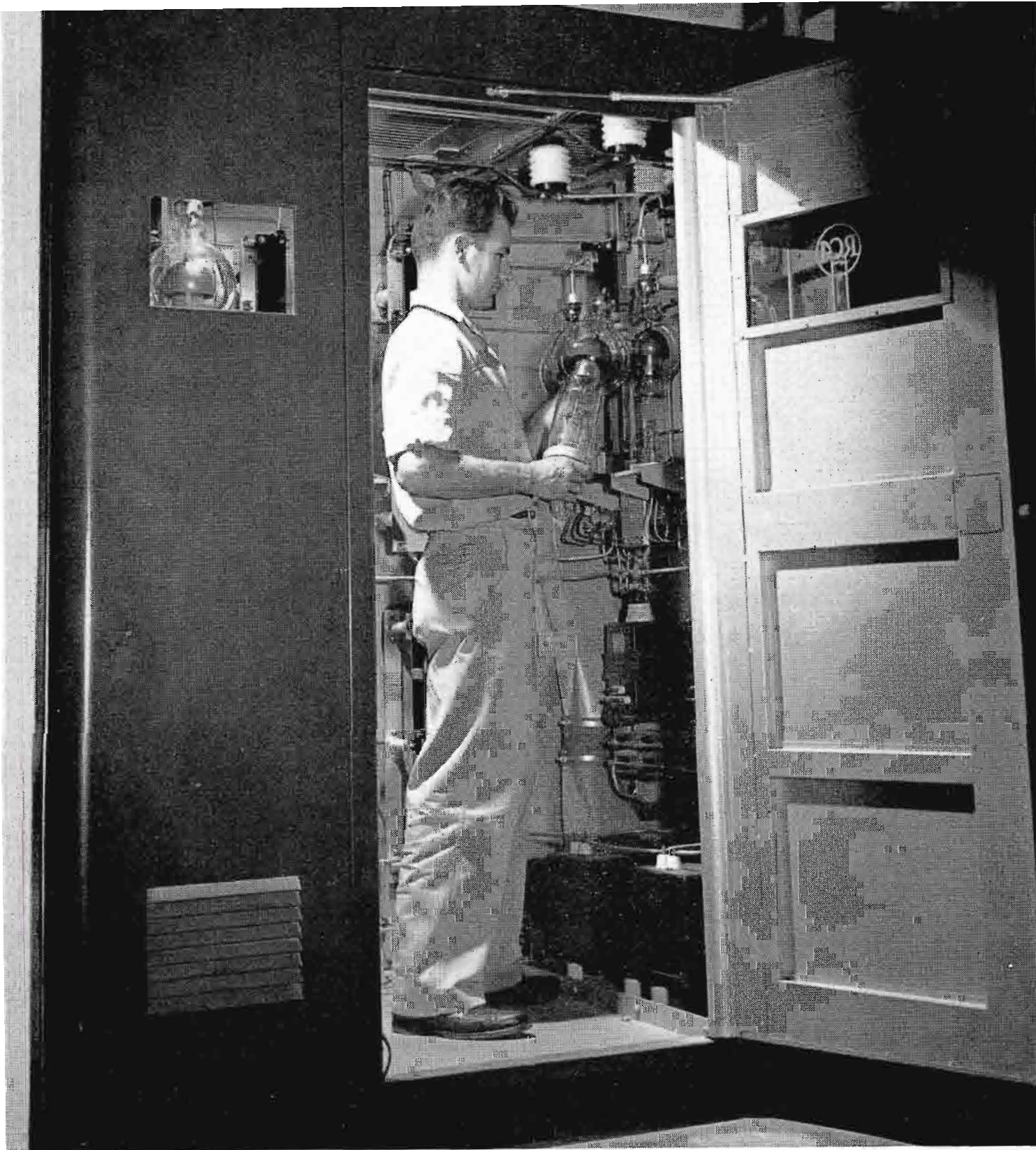
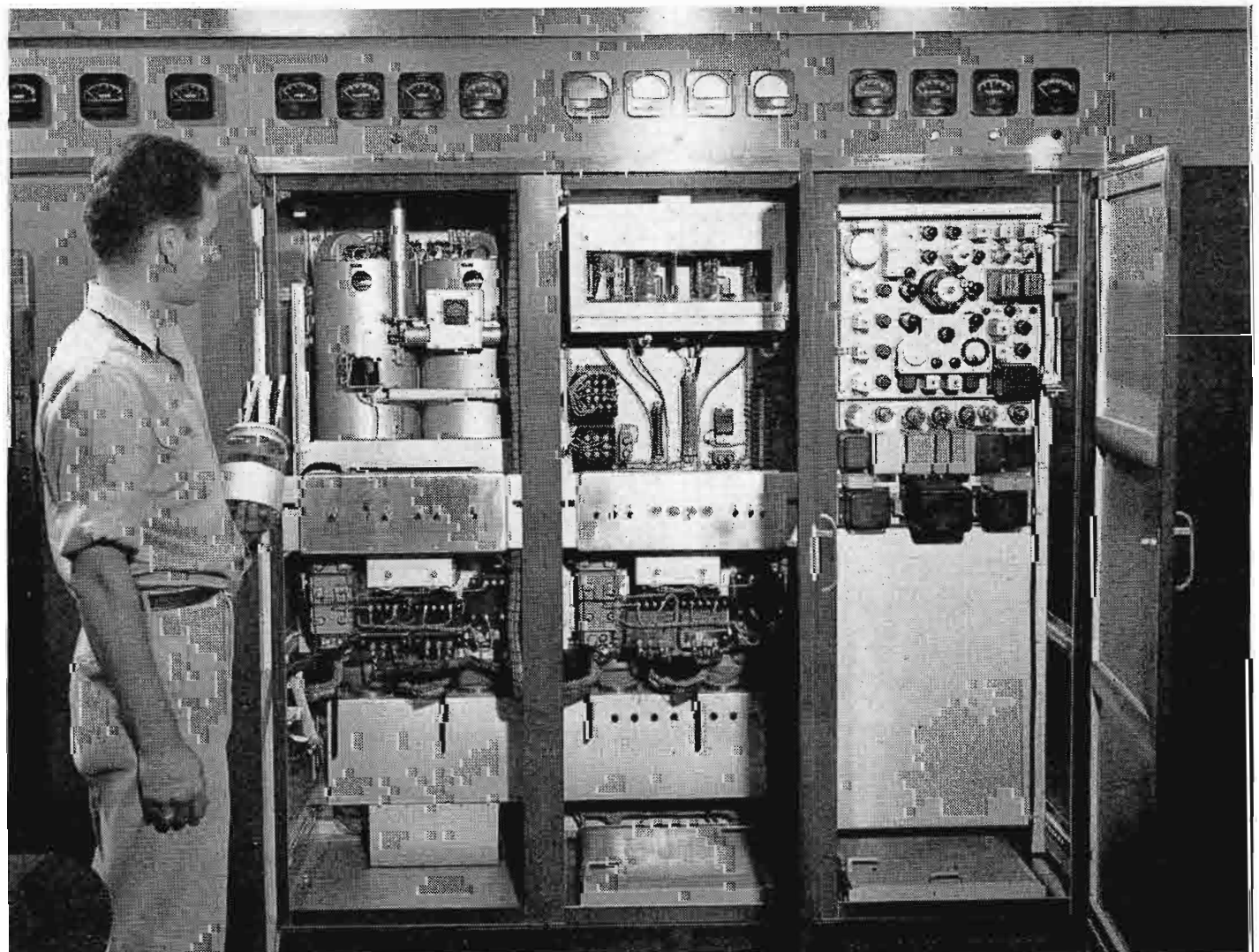

FIG. 9 (at left). WTMJ-FM engineer, Raymond Hernday, is shown installing an 857-B rectifier tube. This photo shows the "walk-in" type construction used for ease of operation and maintenance of all components of the 120 KVA rectifier unit. This rectifier supplies plate voltage to all power amplifier tubes down to and including the  $\frac{1}{4}$  KW amplifier.

FIG. 10 (at right). In this view, an RCA 7C24 tube is ready to be installed in the 10 KW grounded-grid stage at left. The same type tube is used in the 1, 3 and 10 KW grounded-grid stages. The modulator or "Direct FM" exciter unit is visible at right.



**Performance**

The operation of the transmitter has been extremely stable and has turned in an excellent record of continuous performance at 50 KW output on 93.3 megacycles. Measurements have been taken on the transmitter and indicated that the AM noise level runs better than 52 db and the FM noise level better than 65 db which includes studio and a twenty-six mile circuit of the Wisconsin Bell Telephone Company program line. The transmitter performance alone is considerably better

than the preceding figure. Figs. 11 and 12 show that the overall distortion and frequency characteristics to be well within the Federal Communications Commission's requirements. The second harmonic content at 186.6 megacycles was measured one-half mile from the transmitter and compared to a General Radio 804B Signal Generator. The second harmonic signal was found to correspond to 120 microvolts. This value is considered not to be objectionable to other services. Field intensity measurements are now being taken by the station

engineers using an RCA Model 301 Field Intensity Meter. Several preliminary runs have been made out and beyond the predicted twenty microvolt contour and indicate that the performance of the station will more than meet the original estimates of coverage.

In addition to the FM station, the Milwaukee Journal Radio Stations operates WTMJ and WTMJ-TV in Milwaukee, and WSAU and WSAU-FM at Wausau, Wisconsin.

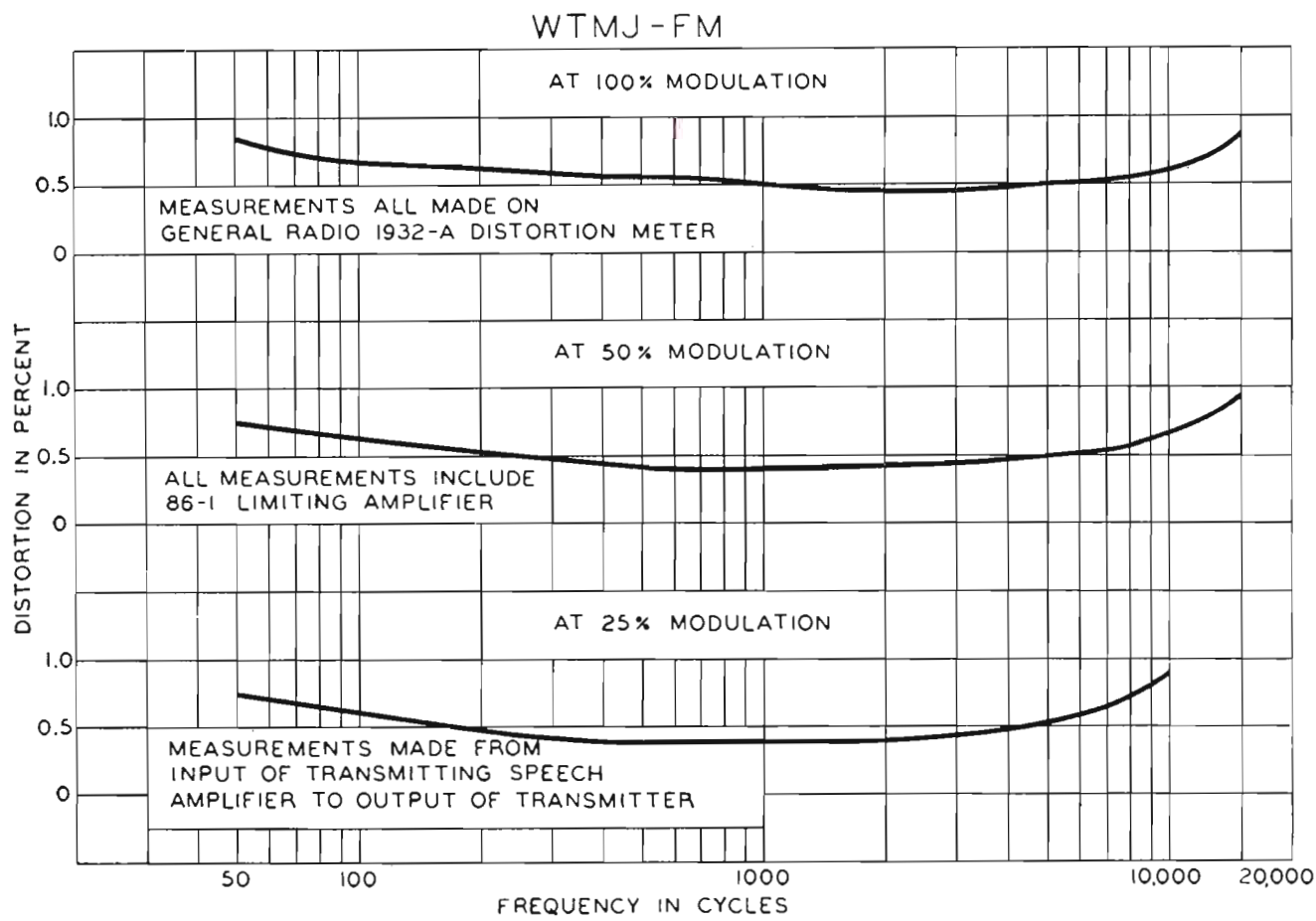
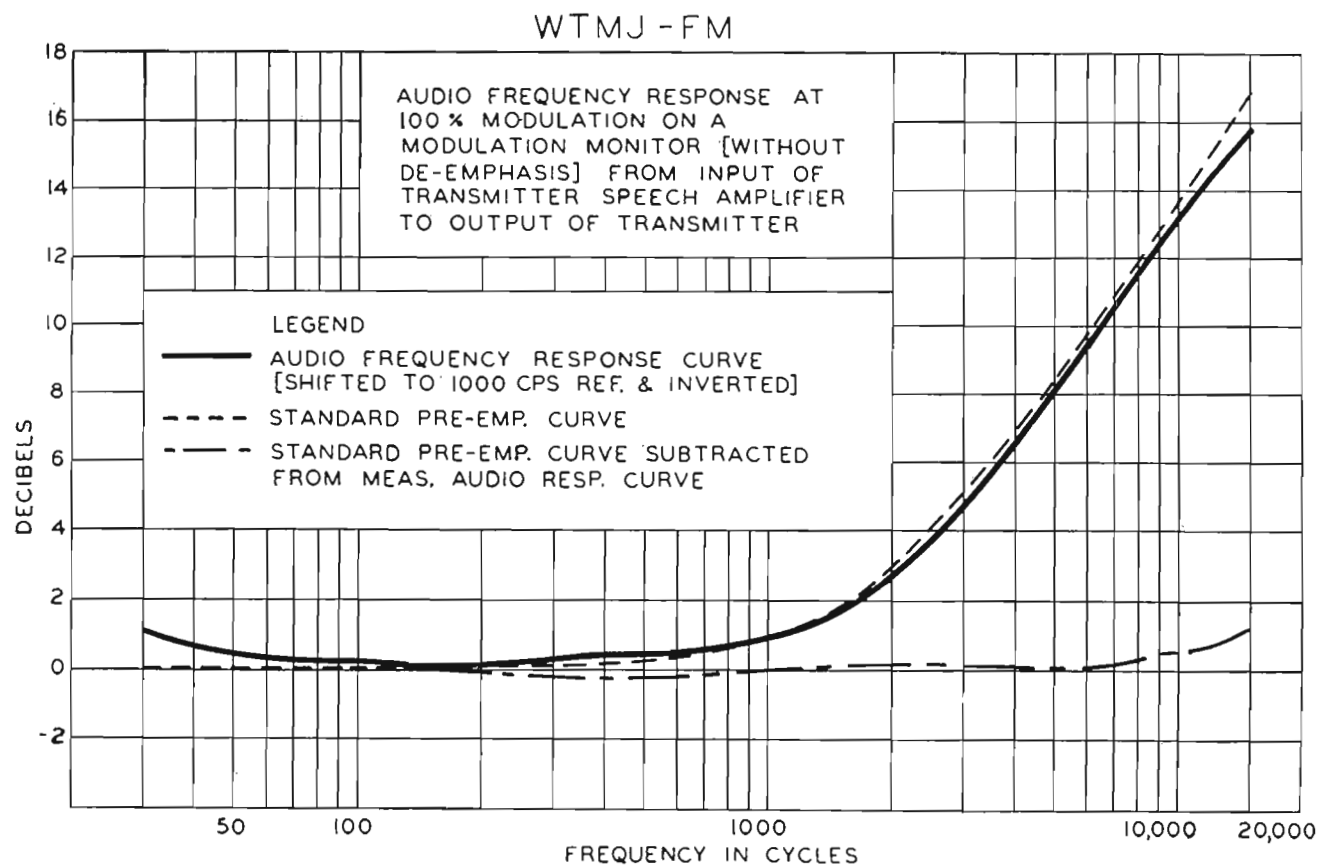

FIG. 11 (at left). As the distortion curves at left illustrate, overall performance of the WTMJ transmitter is well within the FCC distortion limit of 1½% from 30 to 15,000 cycles.

FIG. 12 (at right). Audio frequency response measurements taken on the WTMJ transmitter result in a curve which is essentially flat from 30 to 15,000 cycles.



# WBRC-FM...WORLD'S MOST POWERFUL FM STATION

by **G. P. HAMANN**  
Technical Director and Manager

Extension of FM service to wide rural areas was proven practicable in early November when Station WBRC-FM, Birmingham, Alabama, the world's most powerful FM radio outlet went on the air. Regular reports are being received from

listeners that WBRC "super-power" FM broadcasts provide program entertainment with clarity and without static and interference to rural sections that have never had adequate night-time reception. Coverage obtained has been very rewarding. For

information on measured data and results obtained the reader is referred to O. O. Fiet's article, also in this issue.

The station's new RCA 50 KW FM transmitter, in conjunction with an RCA 8-section Pylon antenna with power gain of 12, develops an effective power of 546,000 watts on a frequency of 102.5 megacycles. WBRC's new broadcasting station achieves maximum program coverage by its ideal location atop Red Mountain, famed iron-ore mountain overlooking Birmingham. The mountain-top is more than 1000 feet above sea level, and the 108-foot antenna surmounts a 450-foot tower.

The Birmingham station which also broadcasts AM programs with its 5 KW RCA 5D transmitter is owned and operated by Eloise Smith Hanna, one of the very few women broadcasters in the country.

## FM Transmitter Building

The Birmingham broadcasting station is a modern one-story, concrete block structure. It is designed to house not only the new 50 KW FM transmitter, but a 5 KW RCA television transmitter, as well as studios and control rooms, etc.

The entire 50 kilowatt transmitter including power control, rectifier and blower equipment is located in the left wing of this building. A test equipment rack and the transmitter supervisory console are also installed in the same area for maximum convenience and efficiency of transmitter operation. Just adjacent and to the right of this wing will be located the television transmitter room and studio facilities consisting of master control room and studio. The extreme right-hand wing is devoted to storage space, garage with parking facilities, and an observation deck.

## The 8-Section Pylon

The combination of the high-gain 8-section Pylon antenna (gain of 12) and 50 KW FM transmitter is capable of providing an effective radiated power of up to 600 kilowatts in serving the wide rural areas surrounding.

FIG. 1 (at left). Situated on Red Mountain, 1558 feet above sea level, WBRC's 8-section Pylon radiates an effective power of 546 KW.

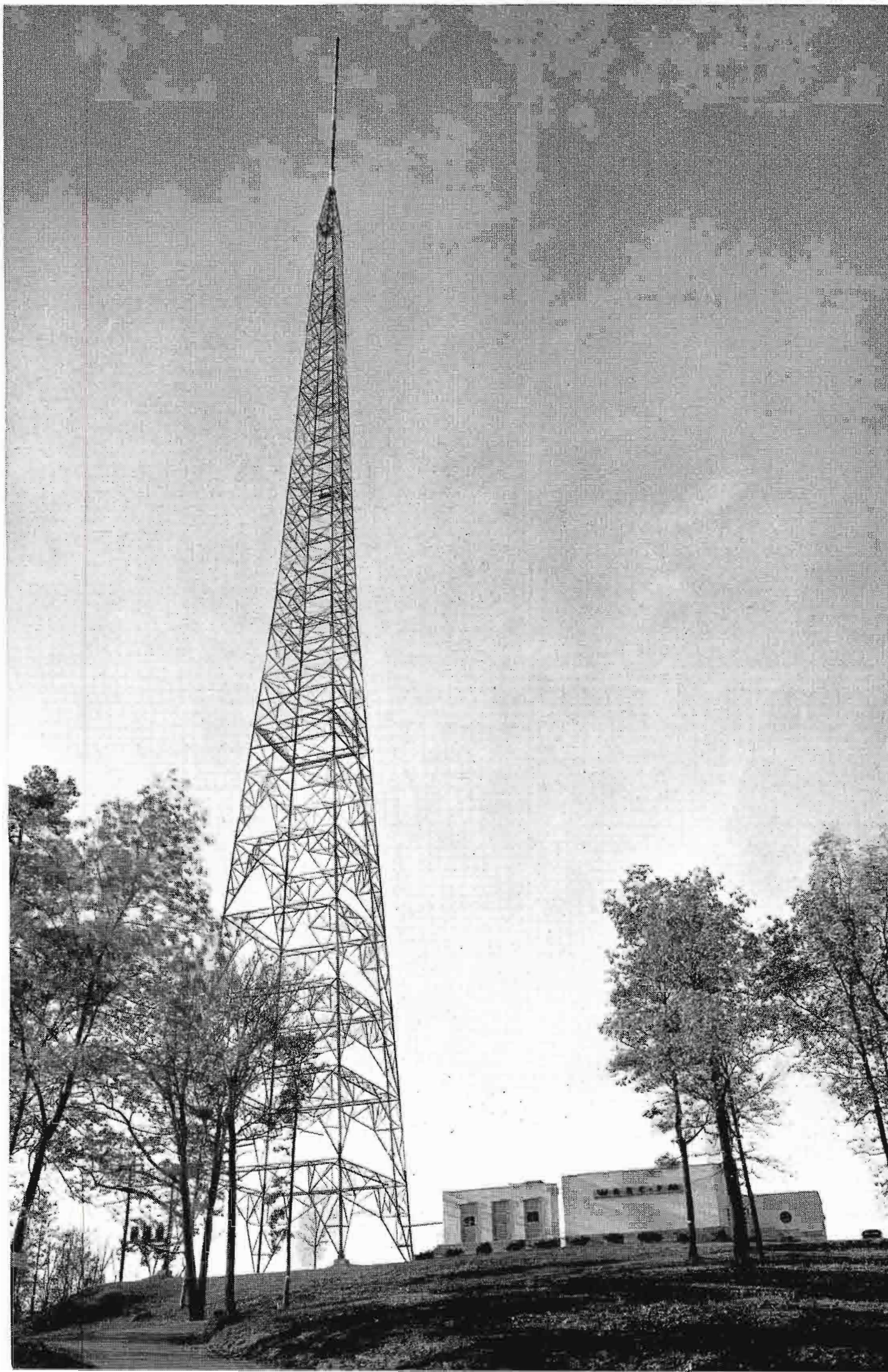



FIG. 2 (above). WBRC-FM's 50 KW transmitter, RCA type BTF-50A, presents a streamlined appearance, with all essential controls front-panel mounted and easy to reach. In this view G. P. Hamann, author, is at the controls while C. J. Starner, RCA engineer, looks on.

The antenna consists of 8 cylindrical Pylon sections which total 108 feet in length. As may be seen in Fig. 1, the antenna is installed in close proximity to the station transmitter house. For additional technical details regarding antenna installation and erection, the reader is referred to O. O. Fiet's article in this issue of BROADCAST NEWS.

#### The 50 KW FM Transmitter

All 50 KW FM transmitter equipment is installed in a single enclosure approximately 30 feet by 24 feet. The entire 50 KW transmitter consists of a series of self-supporting sections behind a single front panel (84 inches high by 16½ feet long) with heavier power equipment arranged in the rear. Due to the small size of individual sections, the moving and installation of equipment into the building proceeded smoothly. During installation, the trans-

mitter was broken down into units no larger than 52½ inches by 84 inches.

As may be seen in Fig. 3, the direct FM exciter, low power amplifiers and necessary blower are located behind the right-hand front panels. In this arrangement the 50 KW blower is located on the left-hand side of the 50 KW amplifier (Driver and Final)—and the balance of the equipment to the rear of R-F sections.

Doors in the front enclosure allow access to the driver and power amplifier, r-f cabinets, and to the transmitter area. With the transmitter "on the air," station personnel may walk behind the enclosure and around the individual units for close inspection. All incoming power supply and high-power rectifier switchgear, lower-power distribution circuits, contactors, and control relays are centralized in a one unit which is located at the rear of the enclosure. This unit also contains the voltage

regulator and distribution transformers. Operational controls, indicating instruments, indicator lights, and tuning controls are located on the front panel and tuning operations required for normal daily adjustments are remotely controlled by front panel key switches controlling motor drives on the tuning elements. Power amplifier tuning controls are conveniently located with respect to the corresponding meters for observing tuning and R.F. output during tuning operations.

Electrically, the low-power amplifiers are grounded-grid circuits with 7C24's used in all stages above the 250 watt level. All amplifier circuits are single-ended and operated Class "C." The driver amplifier uses a single RCA 5592 and drives the two parallel-connected 5592's of the final amplifier. Driver and final are constructed as one unit and electrically and mechanically each unit forms an integral part of

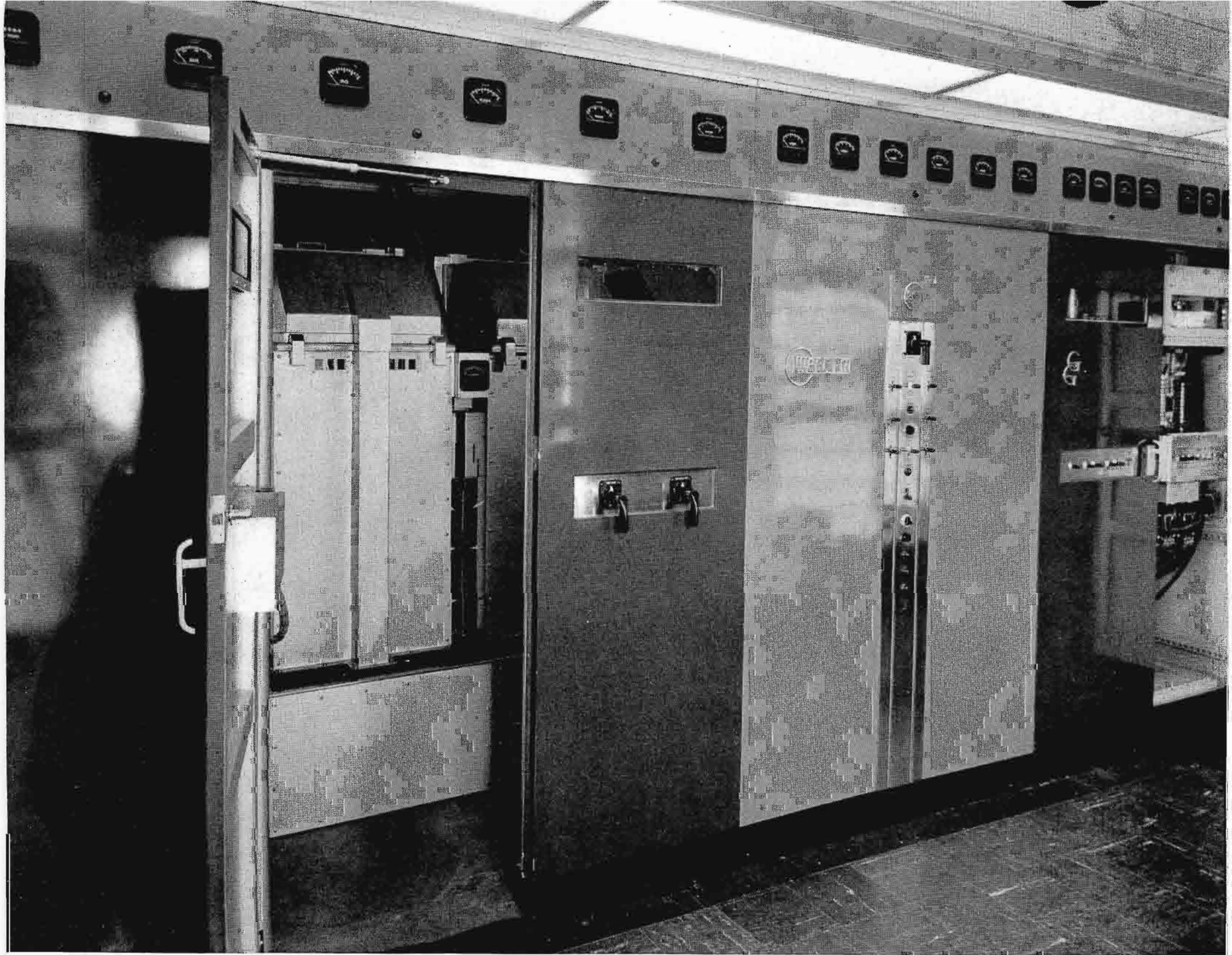
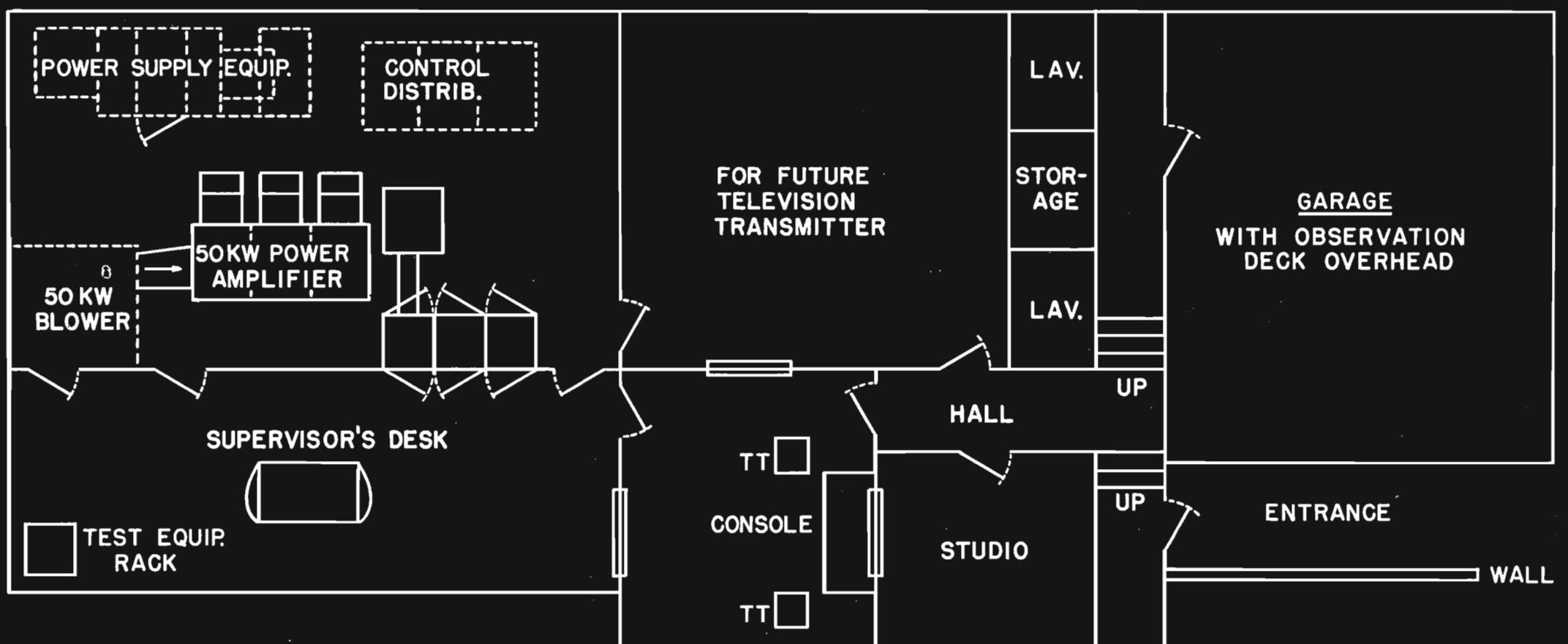
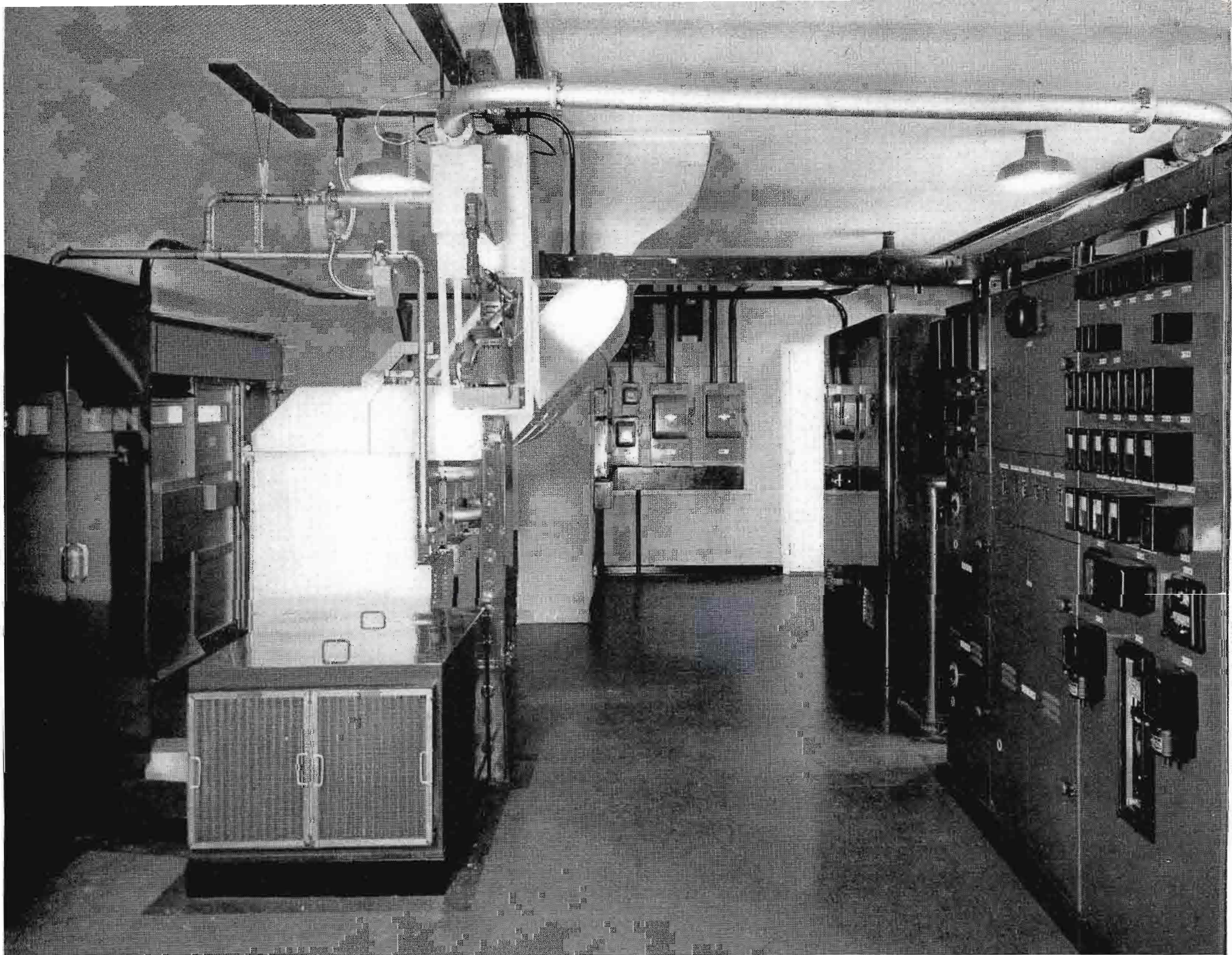

FIG. 3 (above). Front view of the WBRC-FM transmitter with doors opened to illustrate extreme accessibility. Note how 50 KW tanks at left are mounted so as to provide walk-around space.

FIG. 4 (below). WBRC-FM Floor Plan. All components of the 50 kilowatt transmitter are mounted on one floor. Studio facilities and space for future television transmitter are also provided.





**FIG. 5 (above).** This view shows the entire BTF-50A, 50 KW FM enclosure. Low power r-f and exciter are at left, 50 KW grounded-grid amplifier at left center, and H-V rectifier and power and control units at the extreme right. Plenty of walk-around space is provided for every unit of the transmitter.

the grounded-grid circuit. The WBRC-FM 50 KW amplifier is shown in the views of Fig. 3 and Fig. 5. Mechanical construction provides complete shielding of driver and power amplifier and does away with radiation and r-f pickup in adjacent circuits. Mechanically, the base of the concentric-line units forms a plenum chamber for cooling air and also carries control wiring and the high-voltage bus. All amplifier tuning is accomplished from the front panel.

As shown in Figs. 4 and 5, the complete high-voltage rectifier is located at the rear center of the WBRC-FM transmitter enclosure for the convenience of making d-c and a-c connections. All interconnections are made in either built-in or overhead ducts, so that the only conduit or trenches required were those for the supervisory console and incoming power.

The Supervisory Console is located as shown in the floor plan of Fig. 4. It includes both a transmitter control turret and an Audio Control Turret for most efficient station operation. Essential operational controls are duplicated on the r-f turret and the audio turret has necessary controls for program handling.

Two features of the high-power FM transmitter that especially appealed to management were the relatively few number of tubes and spares required—and the provision of power cutback facilities. The power changeover equipment consists of transmission line switches of the trip-latch type which are installed as shown in Fig. 8. Electrical switching to lower power is accomplished by utilizing the impedance characteristics of shorted, quarter-wave transmission line sections to transfer the antenna to the output of the 10 KW amplifier.

#### **WBRC-FM Performance**

In general, no special precautions such as screened rooms or extra shielding were used in the installation. Test equipment is installed at a convenient location, about 8 feet from the front panel and about 6 feet beyond the end of the front panel housing the 50 KW amplifiers. R.F. for the monitor, and audio leads, etc., is carried in a regulation trench. A 4-inch ground strap bonds the test rack to the console and the audio equipment as well as to the transmitter.

Program is fed to the transmitter from an adjacent room, which is acoustically treated but has no special r-f treatment (no shielding). Transcription turntables and audio amplifiers are located in this room with the pre-emphasis network and limiting amplifier located in the test equipment rack.

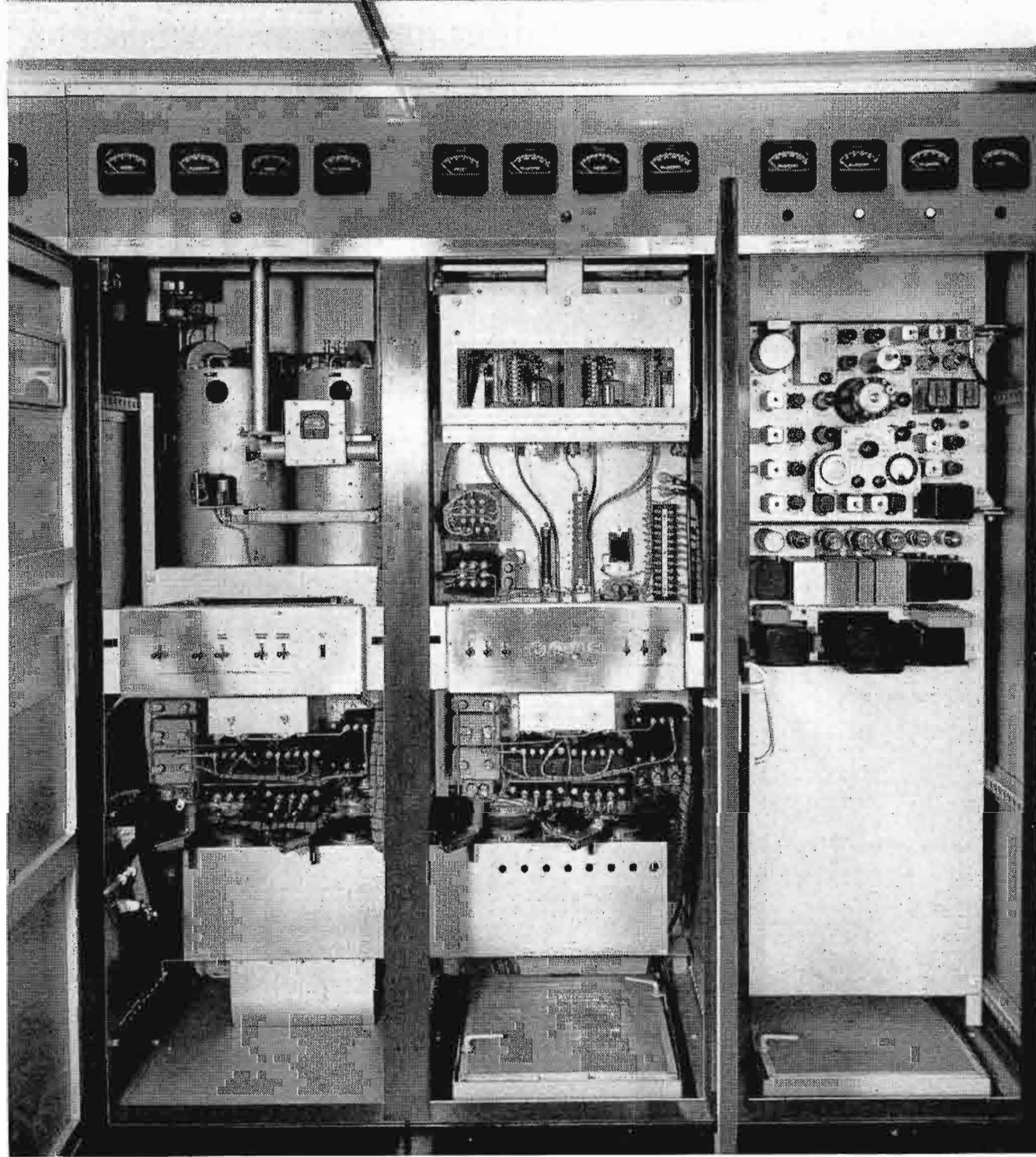
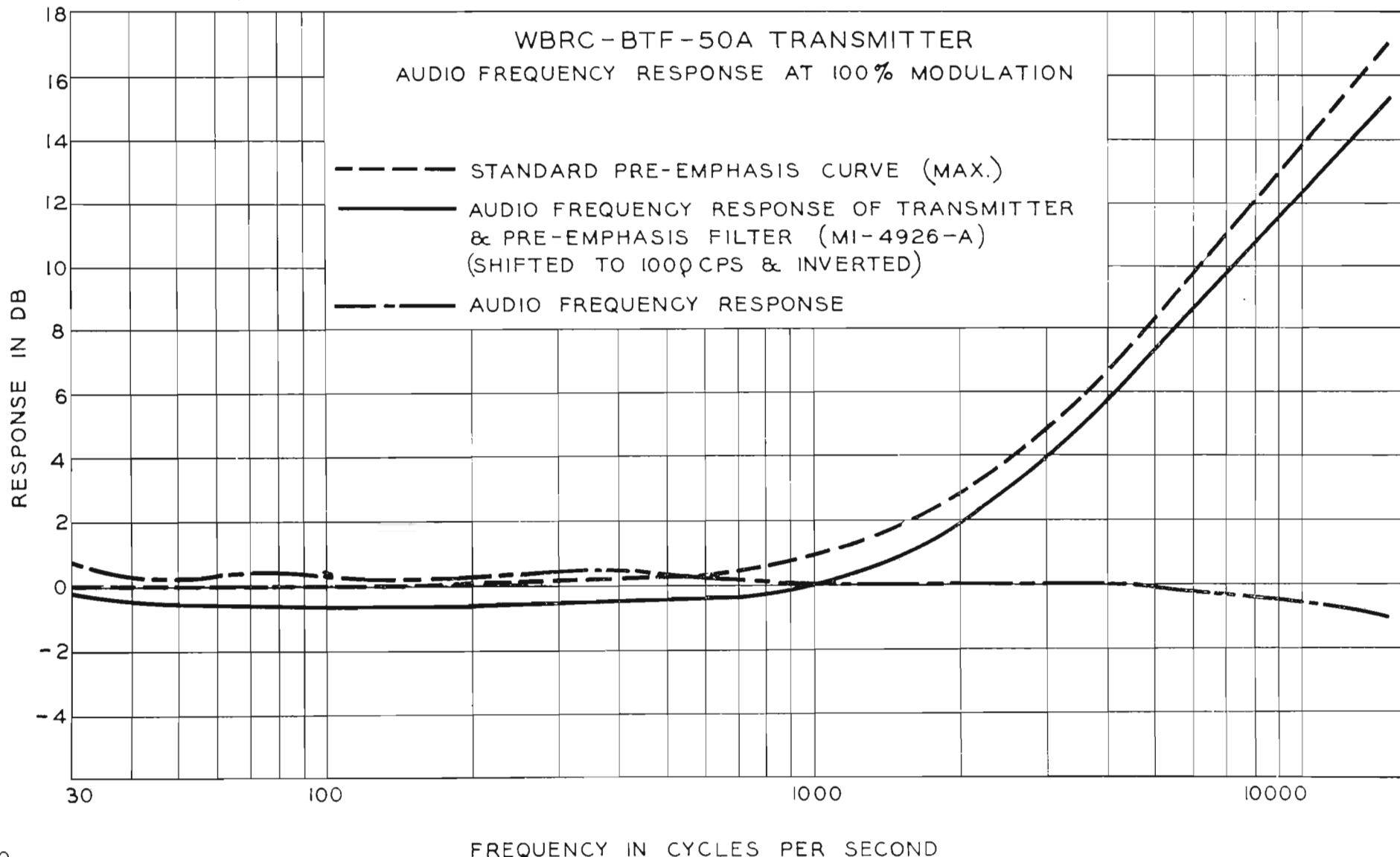

FIG. 6 (above). Closeup view of the "Direct FM" exciter at right, 1 and 3 KW low-power, grounded-grid amplifiers at center and 10 KW grounded-grid amplifier at extreme left.

The taking of complete performance data was entirely routine. Measured distortion, response and noise level data, checked that predicted by RCA, and as measured with a dummy load. No r-f filtering or isolating was necessary. Curves of Figs. 7 and 9 show WBRC-FM frequency response and distortion. FM noise was measured as  $-73$  db, AM noise levels at  $-53$  db with RMS distortion below .7% from 30 to 15,000 cycles, at 100% modulation (75 KC swing). (The above are transmitter and not system measurements.) For predicted performance curves, refer to C. Starner's article on the 50 KW FM transmitter, included in this issue. Program modulation was also routine, and no filtering or special work was necessary. Program amplifiers could be opened to full gain with no sign of r-f troubles.

The transmitter tune-up presented no unusual or serious problems. 50 KW power at 102.5 megacycles was obtained with excellent stability, and dependability. The usual minor difficulties associated with an equipment of this size were present but no serious problems were encountered. Since this was one of the first installations of equipment capable of generating and

FIG. 7 (below). Frequency response curves taken on WBRC-FM's 50 KW transmitter show response to be essentially flat from 30 to 15,000 cycles. (Measurements were taken with antenna load, and isolation or r-f filtering were not necessary.)





radiating power above 500 KW in the 100 megacycle frequency range, there was some speculation as to what problems might be encountered in regard to test facilities, program handling, adjacent stations, etc.

Recalling some of the phenomena encountered when early high-power AM stations went on the air with 500 kilowatts in the 540-1600 kilocycle band in the 1930's, such as nearby neon signs glowing even when turned off, arcing in loose joints in rain-spouts or other metallic joints with audible program, etc., there was some speculation as to whether the neon lights in the nearby statue of "Vulcan" might stay lighted, and whether both WBRC's audio and test equipment as well as those of the nearby FM stations, would be seriously affected.

Although published data of tests made in Camden with 300 KW E.R.P. in the FM band indicated that there would be no troublesome phenomena because of the high power radiated, there still existed some concern because of the close proximity of two relatively low power FM stations on the same mountain location. Happily, no ill effects whatsoever, due to the high power, were noted either in WBRC audio or test equipment or in that of the nearby FM stations.

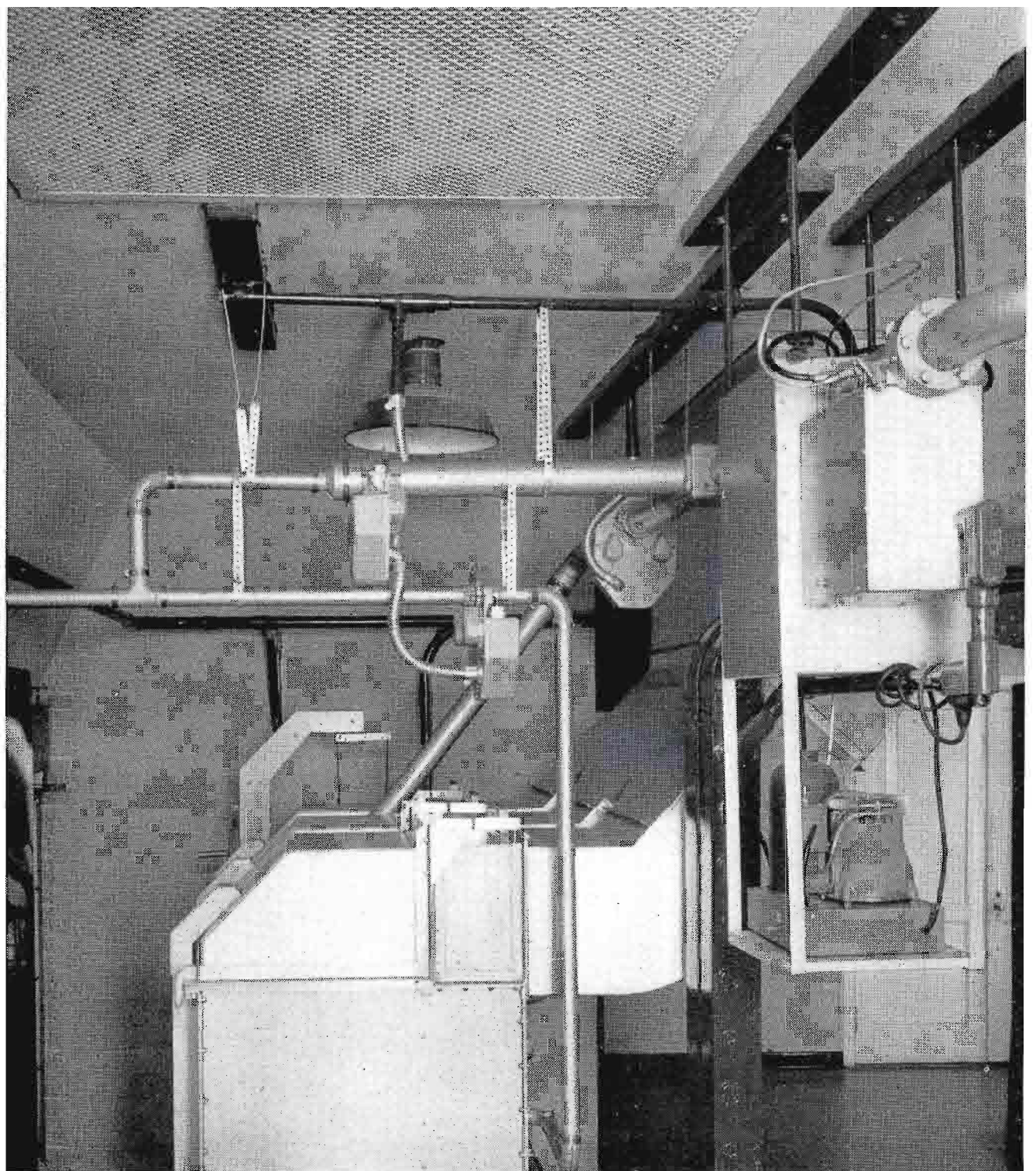
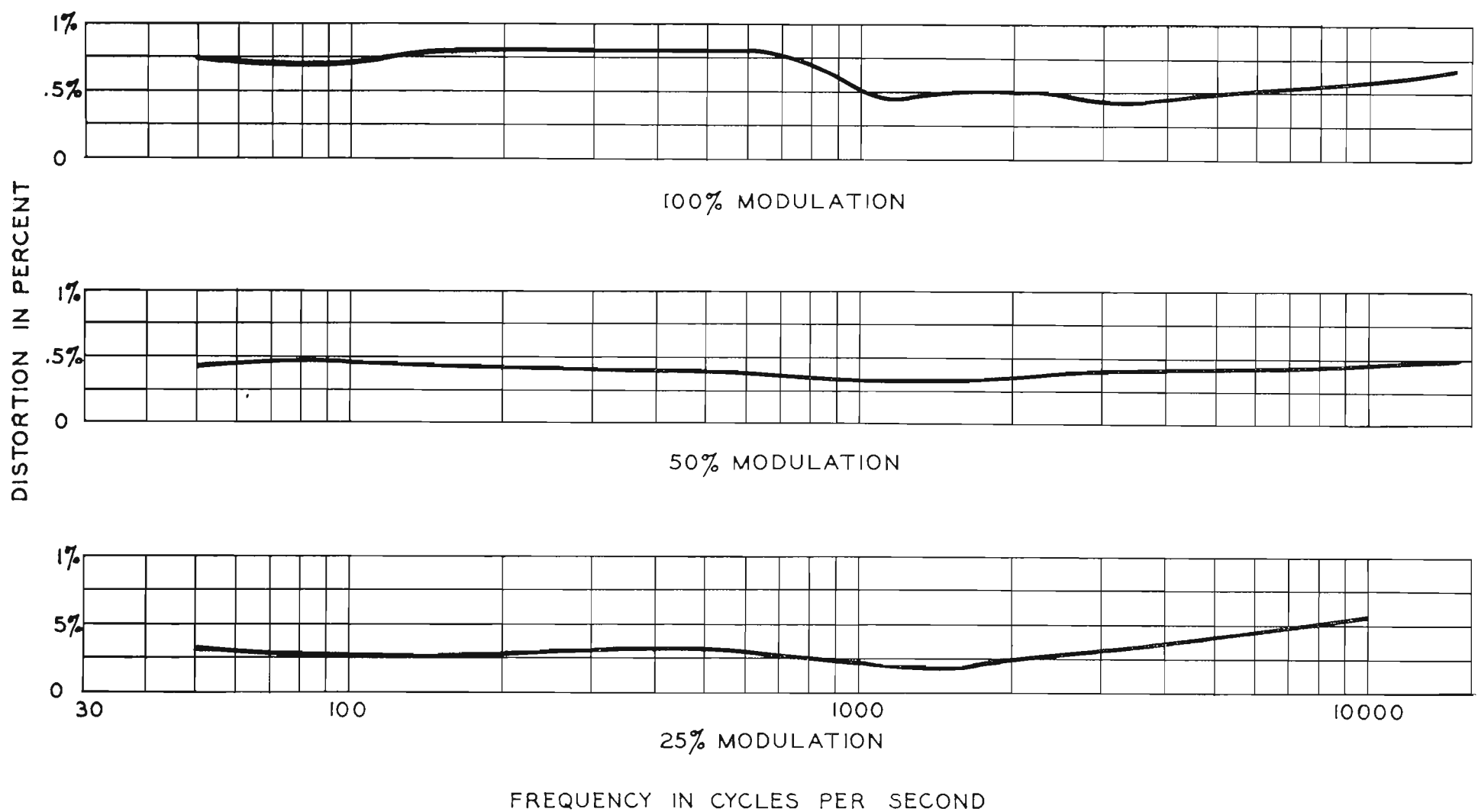

FIG. 8 (above). Closeup of a portion of the 50 KW FM amplifier unit showing the transmission-line power cutback switch arrangement. (Visible in center of photo.) The transmission line monitor and harmonic filter are shown at extreme right.

FIG. 9 (below). Distortion measurements were made at three references, equivalent to 25%, 50% and 100% modulation. RMS distortion was below .7% in all cases from 30 to 15,000 cycles.



# 8-SECTION PYLON MAKES 546 KW A REALITY AT WBRC-FM

FIG. 1. Aerial view of WBRC-FM 8-section Pylon antenna installation, showing Birmingham in the background and the WBRC-FM transmitter house at the tower base.

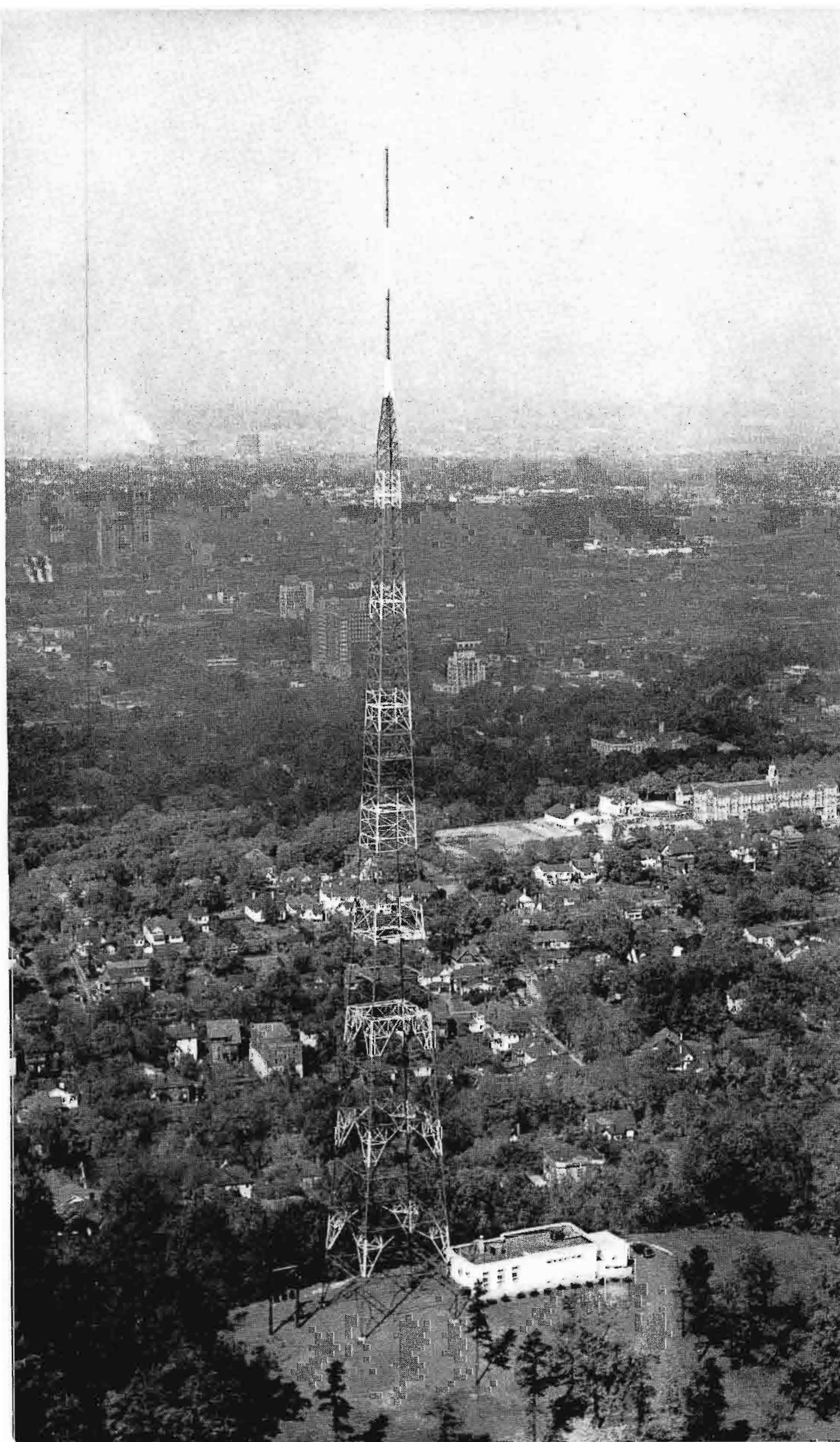

by O. O. FIET

Transmitter Engineering Section  
Engineering Products Department

An RCA BTF-50A 50 KW Transmitter and an RCA 8-section Pylon antenna have enabled WBRC-FM to achieve an effective radiated power of 546 KW. The antenna also makes possible future expansion to 1092 KW by use of a 100 KW FM power amplifier.

It is not surprising that the most powerful FM broadcast station in the world should be constructed in Birmingham, Alabama, since the high noise level in the standard AM broadcast band existing in southern U.S.A. increases as the distance to the Gulf of Mexico diminishes (see Fig. 2). Marine radio operators sailing through the Gulf of Mexico know of the excessively high radio noise level and frequently experience complete radio communication "blackouts" in certain areas. This experience is not confined to marine radio operators alone, but is also well known by all who have had the opportunity to observe the standard AM broadcast reception in these areas. Fortunately, the situation is different in the FM broadcast band where atmospheric noises are naturally at a low level. Thus, commercial high-frequency, high-power FM broadcasting has given the southern U.S.A. broadcaster an opportunity to serve larger primary service areas. "Super-power" FM overcomes many problems confronting the southern AM broadcasters—such as: excessive night-time sky wave interference, expensive directional antennas, and frequency allocation studies required for a new AM broadcast station.

Mrs. Eloise Smith Hanna, owner of WBRC and WBRC-FM, and her staff were quick to recognize the possibilities of a "super-power" FM broadcasting station in Birmingham, one of the largest industrial cities in central southern U.S.A., which has grown to its present greatness over a period of about 70 years, because of a fortuitous and unusual supply of all of the raw materials required in the manufacture of iron, coal, iron ore and limestone. All three materials are available in large quantities and commercial quality within

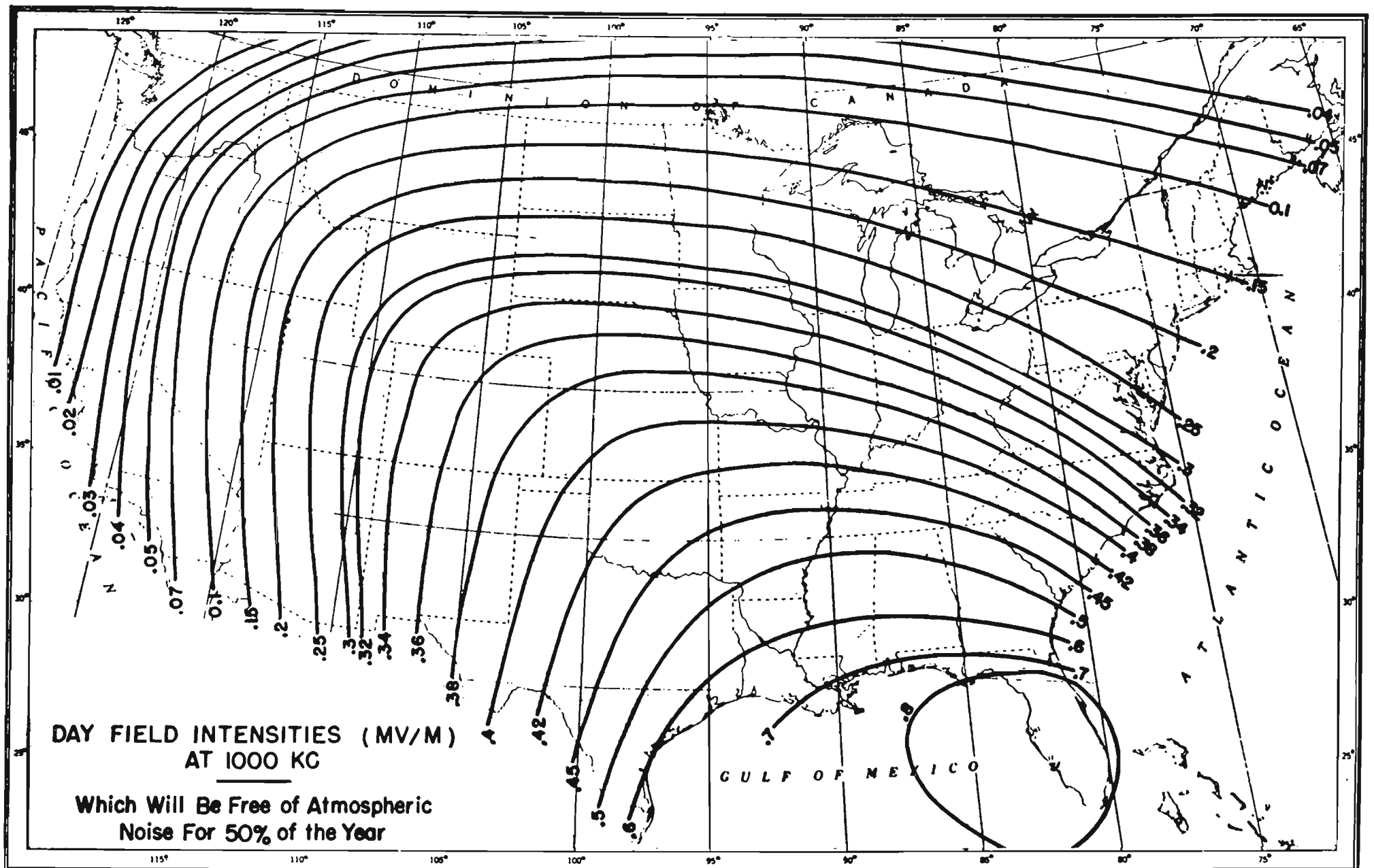

FIG. 2. This noise contour map illustrates the night-time field intensities (millivolts per meter) required to overcome atmospheric noise for 50% of the year at 1000 kc in the standard AM band.

a five mile radius. Red Mountain, upon which WBRC-FM is situated, is one of many mountains in this area which is formed mostly by common iron ore (hematite). The red rust color of the weathered surface of the "iron" mountains is an interesting sight for people visiting Birmingham for the first time.

The high AM broadcast band noise level in and around Birmingham, Alabama, has not permitted adequate night-time coverage, of many surrounding rural sections by AM broadcasting, on an economic basis. Thus, many observers, including RCA engineers, have awaited with interest the results of the FM "super-power" installation. Early reports have been spectacular and especially rewarding were comments received in a recent letter from G. P. Hamann, technical director of WBRC-FM/AM. These comments, which are quoted below, will serve to illustrate the remarkable FM broadcast service being given by WBRC-FM.

1. WBRC-FM has already received over a thousand favorable comments from 22 states.

2. FM broadcast stations 225 miles distant are picking up WBRC-FM signals of sufficient dependability and quality for re-broadcast.

3. WBRC-FM is giving broadcast coverage to rural sections that have never had adequate night-time FM or AM broadcast reception.

4. Many interested broadcasters and engineers observing WBRC-FM now know what "super-power" FM can do.

5. Line-of-sight coverage is not a practical limitation to the service area of an FM broadcasting station. Coverage well beyond line of sight contributes greatly to the service area achieved when sufficient FM power is radiated.

#### Engineering Data and Performance Checks

Fig. 1 shows an aerial view of the tower and 8-section Pylon installed on top Red Mountain (some of the residential and downtown Birmingham is visible in the background). The FM transmitter building, which includes space for television transmitting equipment, is located near the transmission line is carried up the tower

base of the tower. A  $6\frac{1}{8}$  inch concentric to feed r-f power to the 8-section Pylon. This large coax has the greatest power transmission efficiency and capability of any concentric line commercially available. The 50 KW of r-f power which the concentric line carries is considered very conservative operation and will permit future expansion to 100 KW input to the 8-section Pylon by merely adding a 100-KW power amplifier to the present RCA BTF-50A 50 KW FM transmitter. WBRC-FM may thus increase their effective radiated power to 1092 KW with a minimum of alteration and expense if future requirements indicate the necessity of a power increase.

A closeup view of the 8-section Pylon, Fig. 3, shows the simple clean, streamlined appearance of the 8-section Pylon which consists of eight, stacked co-linear cylinders. The ventilator and a standard 300 Mm code beacon are visible at the top of the Pylon.

The two "stub-matchers" for the top and bottom four sections and the adjustable trombone phasing adjustment which permits variation of the vertical pattern

tilt to achieve the best possible coverage are visible in Fig. 4. Fig. 4 shows a closeup of the stub-matcher and pattern tilting units in the tower top just below the bottom Pylon section. These units may be mounted elsewhere in a position best suited to a particular station installation.\*

The two "stub-matchers" permit a very accurate adjustment of the power distribution\* to the top and bottom four sections

to obtain the greatest possible gain, efficiency, and a very good input standing wave ratio to the antenna system. The voltage standing wave ratio measured with a precision measuring line after adjustment of the stub-matchers at WBRC was 1.03. This standing wave ratio is considerably better than the maximum of 1.10 considered necessary to meet the severe impedance requirements of a television trans-

mitting antenna, and of course, many times better than the maximum "SWR" of 1.5 established by the RMA for FM broadcast antennas.

The trombone phasing adjustment permits variation of the vertical pattern tilt up or down as desired to obtain the best possible coverage for any 8-section Pylon installation. The "trombone" may be varied for maximum field strength at any desired distance and location.\*\* The final adjustment may easily be changed later, whenever it is desired to obtain different coverage characteristics.

### Coverage

The field intensities of WBRC-FM were measured at many locations by RCA engineers, and because of the irregular terrain a precise comparison could not be made with calculations based upon the FCC standards of good engineering practice. However, comparison with field intensities established at the same receiving location by other FM stations near Birmingham gave a very good comparison and appropriately accounted for the local terrain and environment. The average of a large number of field strength measurements of WBRC-FM and another FM station in the locality gave a measured ratio of WBRC-FM's field strength of 42-to-1 compared with the predicted ratio of 33.5-to-1. The latter ratio was based upon effective radiated power and height of the transmitting antenna. This indicates a field strength approximately 25% greater than expected and corresponds to a 56% increase in effective radiated power. This same bonus in signal intensity has been observed at other commercial 8-section Pylon installations.\*\*

Many field strength measurements were made at various locations, behind hills and bluffs—in deep holes—and gullies. These locations were selected after a study of topographic terrain and profile maps to obtain the most pessimistic field strength data. The lowest field strength measurement obtained at any point for close-in locations out to ten miles was 7000 microvolts per meter—7 times the signal required for good metropolitan service. A sensitive field strength meter was used and it was not possible to detect other FM stations in this *particular close-in location*. However, most of the field strength measurements of WBRC-FM at all terrain locations out to 10 miles varied between 600,000 and 20,000 microvolts per meter. The 7000 microvolt reading included de-

FIG. 3. Closeup of the high-gain, 8-section Pylon as installed on the 450 foot WBRC-FM tower.

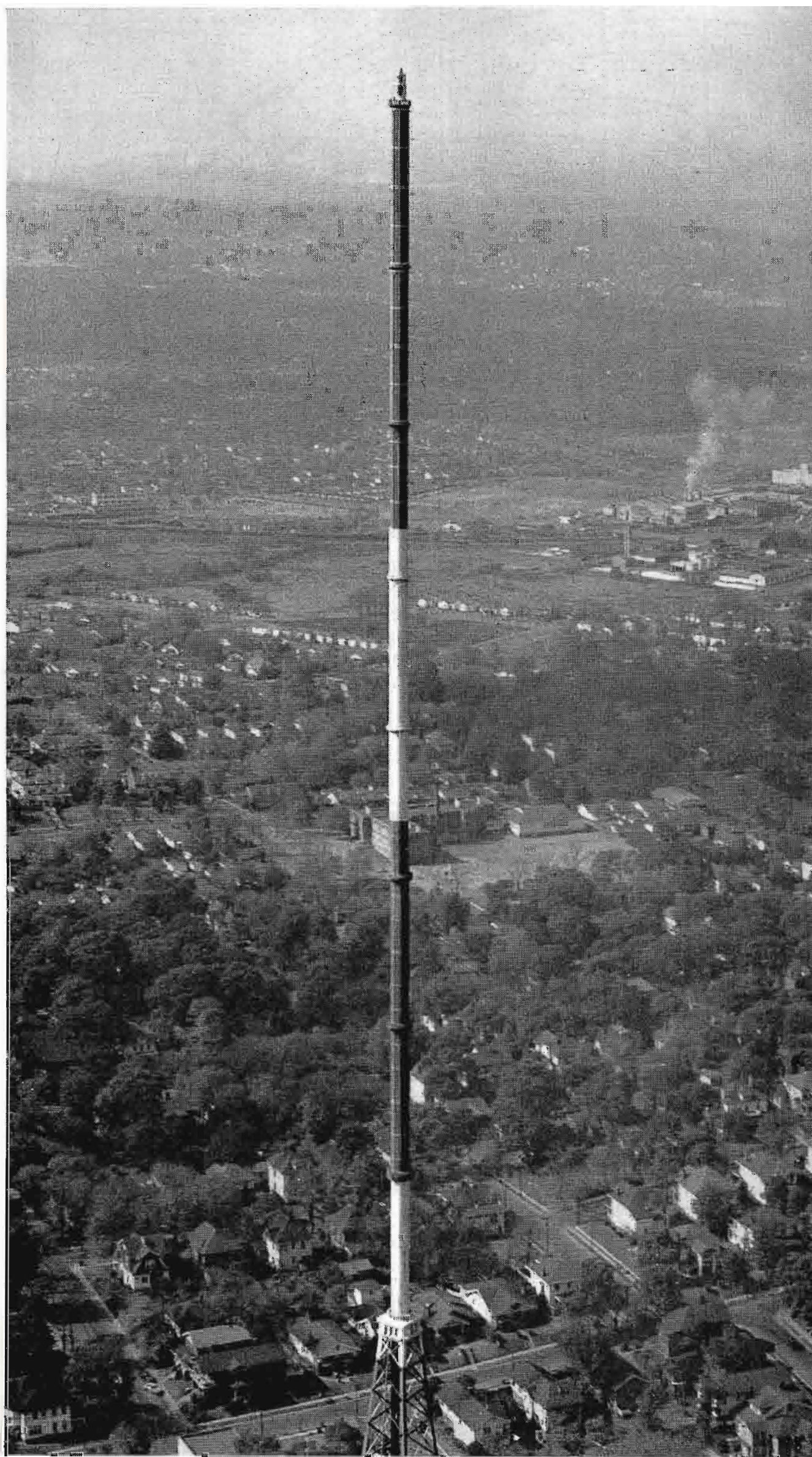

structive interference of received signals reflected from the local environment, and movement of the field-strength-meter antenna a few feet resulted in much higher field intensity readings. The mountainous terrain around WBRC-FM was far from ideal for best FM reception, however the signals established in even the most unfavorable locations are many times more than adequate.

The unusual coverage characteristics of the 8-section Pylon does have a logical explanation. The adjustable vertical pattern tilt contributes greatly to this bonus of signal strength achieved. Engineering calculations indicate that a proper downward tilt of the vertical pattern determined by terrain and transmitting antenna elevation can increase the line-of-sight field strength up to 3 db. This is accomplished without reducing the useful signal beyond line-of-sight, and at the same time high-angle radiation which causes undesirable tropospheric transmission may be reduced. Experience on previous 8-section Pylon installations with the adjustable vertical pattern tilt confirm the increased signal intensity observed at WBRC-FM.\*\* The beam tilt feature will enable field strengths up to 2000 KW effective radiated power to be obtained with the 8-section Pylon and a 100 KW FM transmitter. The 8-section Pylon is the only commercial FM broadcast antenna available with a "steerable" vertical pattern. Unidirectional antennas with steerable beams\*\*\* (the "Musa," multiple unit steerable antennas) have been used for many years in short-wave broadcasting and for communication work where they have proven their versatility and practicability.

The top of the 8-section Pylon rises 558 feet above the top of Red Mountain giving an elevation about 1560 feet above sea level and an effective center of radiation approximately 1000 feet above the average terrain. The line-of-sight distance for a 30 foot receiving antenna elevation is 45.4 miles. The distance to the 50 micro-volt per meter contour is about 100 miles, representing the FCC standard limit for the primary service area. It is important to note that the accepted service radius of WBRC-FM which extends 54.6 miles beyond or over twice line-of-sight distance illustrates that line of sight is not a serious limitation on service radius. The 100 mile service radius does not represent the actual limit of high-quality, dependable FM re-

ception with a suitable FM receiving system. FM stations 225 miles distant are receiving WBRC-FM signals of high dependability and quality, suitable for FM re-broadcast.

Although WBRC-FM is doing a spectacular job of coverage with "super-power" FM, the performance achieved does not represent the practical limit of service radius. FM stations in the western United

States, where accessible mountain elevations are sufficiently high, may attain primary service area radii up to 200 miles when using the same E.R.P. as WBRC-FM.

\* "The Eight-Section Pylon," by O. O. Fiet, BROADCAST NEWS, Sept. 1948.

\*\* "WKJG Erects 8-Section Pylon," BROADCAST NEWS, Sept. 1948.

\*\*\* Terman — Radio Engineers' Handbook, First Edition — Page 822.

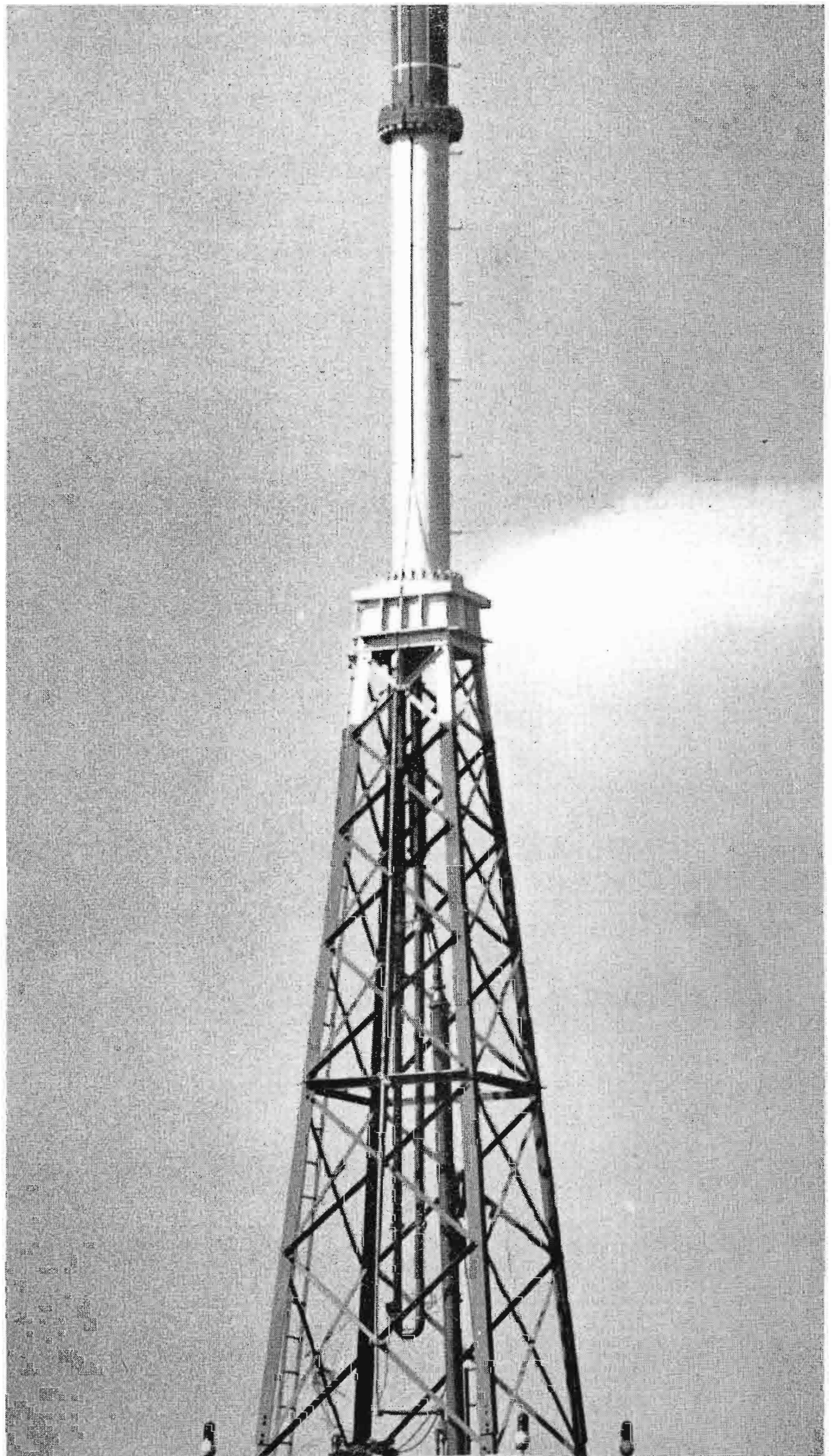

FIG. 4. Phasing and matching units are installed at the tower top as shown in this closeup view. Trombone phasing adjustment used for optimum vertical pattern tilt is visible within the tower.

# How to Make FM "PROOF-OF-PERFORMANCE" MEASUREMENTS

By **F. E. TALMAGE**  
Transmitter Engineering Section  
Engineering Products Department

## I. GENERAL

The Federal Communication Commission's Form 302, Section 11B, Paragraph 6 specifies the performance measurements that FM Broadcast stations are required to make when applying for a license. A list of these measurements is included in Appendix 1, at the end of this article. Although the FCC has temporarily waived the requirements for "proof-of-performance" measurements, it is probable that in the near future this information will become mandatory for all FM stations both when applying for a license and yearly thereafter. The purpose of this article is to guide the broadcaster in choosing suitable test equipment and to be of as much help as possible in making the measurements.

The minimum performance requirements have been specified by the FCC in Section

8A of the FCC "Standards of Good Engineering Practice Concerning FM Broadcast Stations." For your convenience, the applicable sections of the "Standards" are reproduced in Appendix "2" at the end of this article.

## II. TEST EQUIPMENT REQUIRED

The major items of test equipment required in order to adequately make the measurements are listed below. It is assumed that the station already has a good modulation monitor which provides a low-distortion, de-emphasized audio output with sufficient level for feeding a noise and distortion meter.

### (a) Audio Oscillator

Either the RCA 68B (continuously variable B.F.O.) or the RCA WA-28A push-button Audio Oscillator may be used for making the measurements. The RCA WA-28A, with convenient push-button frequency selection, is particularly suited for making the distortion measurements on the FCC specified frequencies. The RCA 68B

is a variable beat frequency oscillator which permits response to be measured at additional frequencies, and a more complete response curve plotted.

### (b) Attenuator Panel

An accurate attenuator panel and a signal level indicator is required for use at the input of the microphone pre-amplifier. Because of the pre-emphasis at the higher frequencies, the input level will change approximately 17 db as the frequency is varied. An additional 12 db of attenuation is required to reduce the modulation level from 100% to 25%. It is therefore recommended that the attenuator panel be capable of varying the input level at least 35 db. The RCA 89C attenuator panel will serve to measure the input level and will also provide variable attenuation up to 75 db.

### (c) Noise and Distortion Meter

Both the RCA 69C and the RCA WM-71A noise and distortion meters will meet FCC requirements inasmuch as they read harmonics considerably above the 30

FIG. 1a (right). Arrangement of test equipment which may be used for distortion and FM noise measurements, when transmitter is located remote from studio.

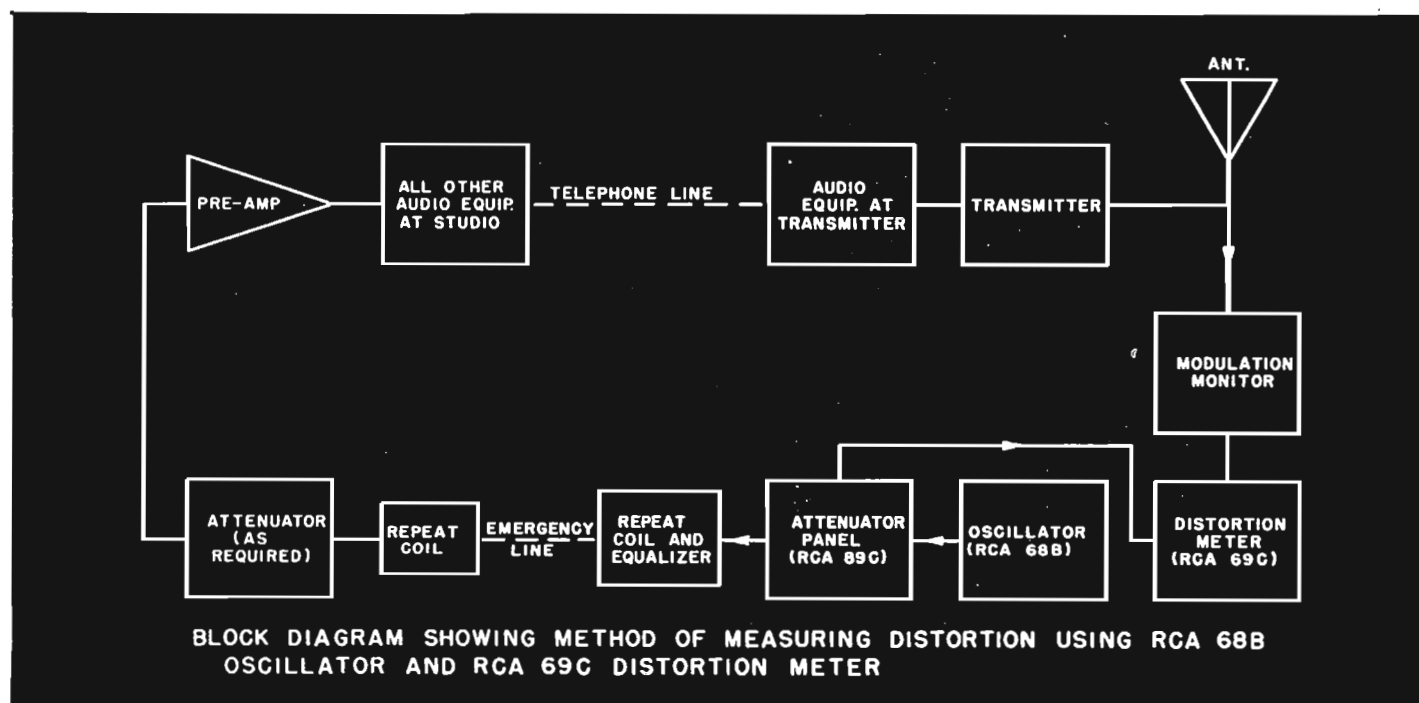
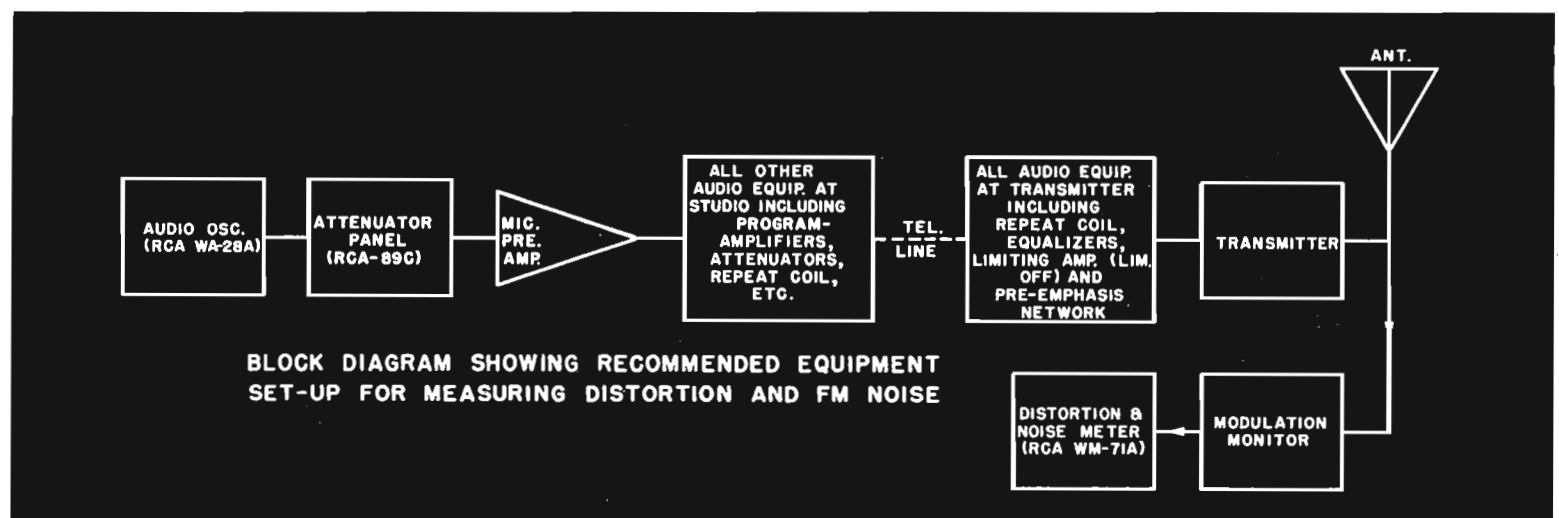

FIG. 1b (left). Equipment setup for measuring distortion, when transmitter is located adjacent to studio, or where a second line with low noise and distortion is available.

kc requirement specified by the FCC. The RCA WM-71A can be used at all installations (see Fig. 1a). However, the RCA 69C can be used only where a second circuit with low noise and distortion level exists between the studio and transmitter locations (see Fig. 1b). The RCA 69C requires the transmission of the original signal from the oscillator to the distortion meter in addition to the program circuit path since this instrument utilizes a balancing arrangement for the elimination of the fundamental frequency.

#### (d) R.F. Rectifier

Since most commercial FM modulation monitors do not have built-in diode detectors, some form of detector or R.F. rectifier is required in order to measure the amplitude modulated noise on the carrier. A schematic diagram of a suitable rectifier is shown in Fig. 3. Since all of the components of this rectifier are readily obtainable from local sources, it is felt that many stations will want to build their own rectifiers. For those who want to go still further, a more elaborate equipment is described in Appendix 4 at the end of this article. This equipment is much easier to use and will give direct readings when used in conjunction with any noise meter.

### III. MAKING THE MEASUREMENTS

The FCC specifies that "All measurements shall be made with the equipment adjusted for normal program operation and shall include all circuits between the main studio microphone terminals and the antenna output, including telephone lines, pre-amplifier circuits and any equalizers employed except for microphones, and without compression, if a compression amplifier is installed."

What is implied by normal program operation is subjected to some interpretation since the level at the microphone input transformer and the resulting overall gain of the system will vary considerably depending on the type of program and the distance the performer is stationed from the microphone, etc. This is an important consideration particularly when making noise measurements, since any hum or noise which originates in the pre-amplifier will obviously affect the measurements directly in proportion to the overall gain of the system. The RMA has recommended a standard system gain of 68 db and also specifies the standard output level into the telephone line as +18 dbm and the standard input level as -50 dbm. It is considered that these levels are consistent with the peak readings occurring during

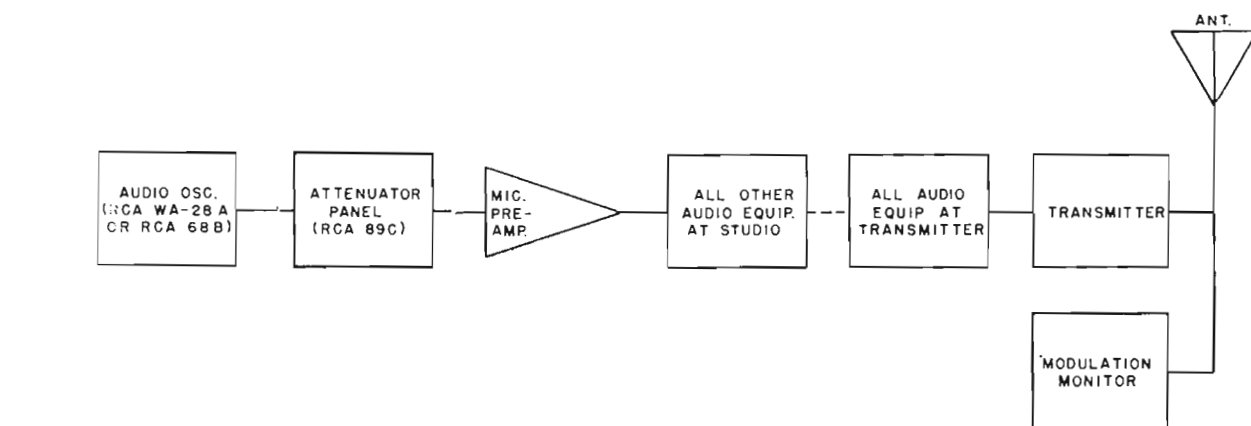

FIG. 2 (above). Block diagram of recommended equipment setup for measuring audio frequency response.

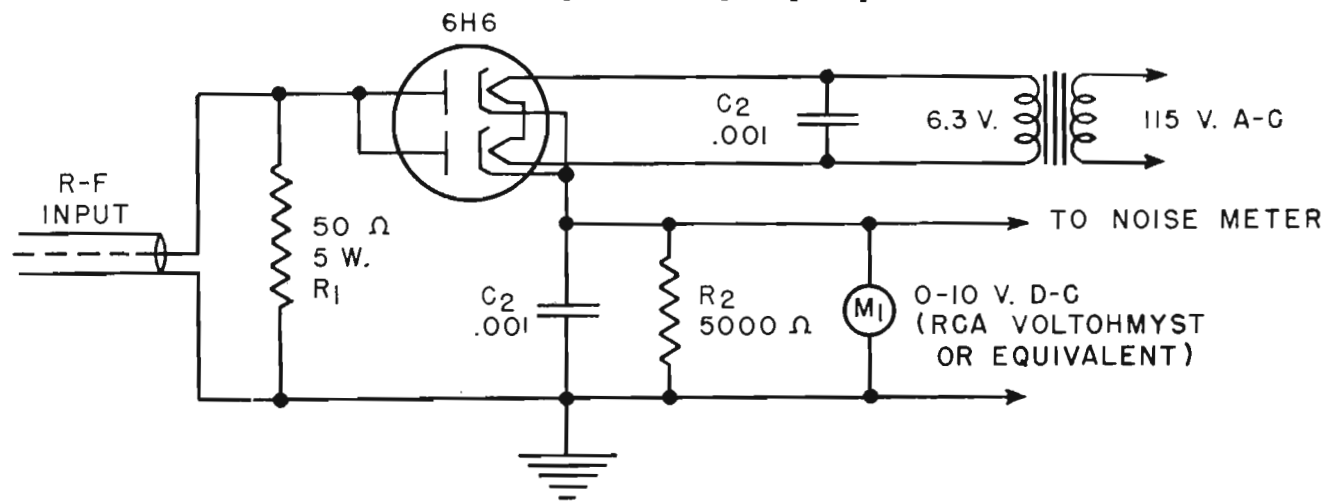
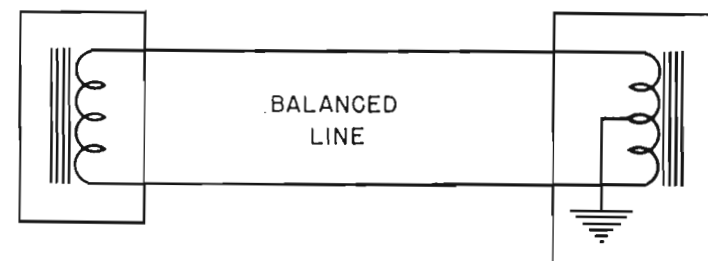

FIG. 3 (above). Schematic diagram of R-F rectifier which may be used for AM hum measurements.

FIG. 4 (right). Sketch showing how loop between transformer coupled units should be grounded.



a normal broadcast program. The RMA recommendations have now been generally accepted throughout the industry.

Another important thing to be kept in mind when setting up the audio system is that the level at all points in the circuit should be kept high enough to override any hum or noise generated in that part of the circuit. As an example, the noise level at the output of the RCA BA-3C program amplifier is less than -82 db below +30 dbm. It follows, therefore, that if the actual output level at which this amplifier is used is 0 dbm, the relative noise level can be as high as -52 db which, of course, will not meet the FCC requirements. In general, the levels should be kept as high as possible without overloading the amplifiers or, in the case of a telephone line, causing crosstalk. In most places, the maximum input level to a telephone line is +18 dbm (level also suggested by RMA); however, it is suggested that this be verified by the local telephone company. In some cases it may be necessary to insert attenuation pads in the output circuit of the various amplifiers in order to raise the amplifier output levels to the proper values.

Another important consideration is the correct use of grounds throughout the audio system. In general, the loop between transformer coupled units should be grounded at only one place—usually at the center tap of the input transformer, as shown in the sketch of Fig. 4.

If an RCA 68B oscillator is used, the center tap of the output transformer should be grounded. Likewise, the center taps on the 89C attenuators should be grounded. If a long line exists between the 68B oscillator and the input transformer of the equipment under test, a "one-to-one" isolation transformer or repeat coils should be used to isolate the grounds—otherwise high noise and distortion may result. The use of shielded patch cords is recommended for all low-level circuits. This is particularly important for the connection between the attenuator panel and the microphone pre-amplifier.

#### Output Noise Level (Frequency Modulation)

It is suggested that the FM noise measurements be made first because the noise is most likely to affect the final selection

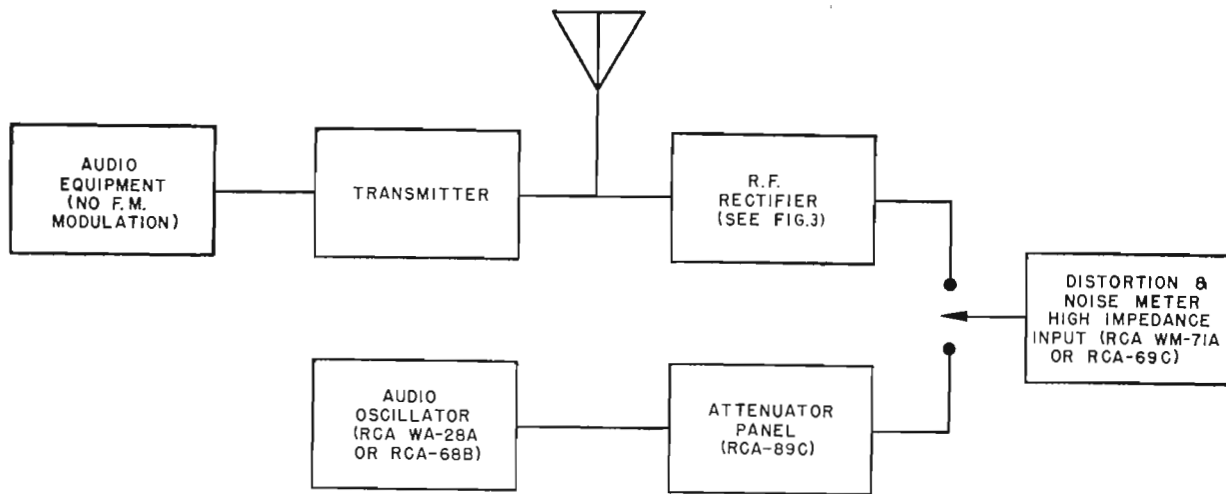

of level settings throughout the system. To make noise measurements, set up the measuring equipment as shown in Fig. 1a, and proceed as follows.

1. Set audio oscillator at 400 cycles.

2. Set all attenuators, both the studio and transmitter, to their normal setting and adjust audio oscillator and attenuator panel settings for 100% modulation as indicated on the modulation monitor. (If there is any question as to the accuracy of the modulation monitor, it may be checked using the Bessel zero system described in Appendix 3.)

3. Measure the signal level at the input to the microphone pre-amplifier (this should be -50 dbm). If not, re-adjust the system gain until 100% modulation is obtained with -50 dbm input.

4. Set the noise meter for zero reference level.

5. Disconnect all equipment from the pre-amplifier input and load the input with a resistor equivalent to the microphone output impedance.

6. Measure and record the FM noise level as indicated by the noise meter. If the FM noise level is not less than -60 db below the 100% modulation reference level, the best way to proceed is to open up the circuit at successive points starting with the input to the transmitter. At each point the input circuit being opened should be terminated with a suitable load resistance. In this way the source of the hum can be localized.

### Audio Frequency Harmonic Distortion

The distortion measurements should be made with the same gain settings and equipment setup as used in making the FM noise measurements. (See Fig. 1a or 1b.) Proceed as follows:

1. Set audio oscillator frequency to 50 cycles.

2. Adjust audio input (oscillator output and attenuator panel settings) for 100% modulation as indicated on the modulation monitor.

3. Measure the distortion at the output of the modulation monitor. De-emphasis

FIG. 5 (top left). Block diagram of equipment used for performing AM noise measurements.

FIGS. 6 and 7 (at left). RCA Service Company forms employed to properly tabulate FM performance test data.

**RCA SERVICE COMPANY, INC.**  
A RADIO CORPORATION OF AMERICA SUBSIDIARY  
CAMDEN 2, NEW JERSEY

**F. M. TEST DATA SHEET**

REGION \_\_\_\_\_ DATE \_\_\_\_\_

RADIO STATION \_\_\_\_\_ LOCATION \_\_\_\_\_ STATION ENGINEER \_\_\_\_\_ RCA SERVICE CO., ENGINEER \_\_\_\_\_

TYPE \_\_\_\_\_ SERIAL # \_\_\_\_\_ CHANNEL NUMBER \_\_\_\_\_ OPERATING FREQUENCY \_\_\_\_\_ MC TRANSMITTER OPERATING POWER \_\_\_\_\_ KW

TOWER MANUFACTURER \_\_\_\_\_ HEIGHT \_\_\_\_\_ FT. TRANSMISSION LINE TYPE \_\_\_\_\_ IMPEDANCE \_\_\_\_\_

ANTENNA MANUFACTURER \_\_\_\_\_ TYPE \_\_\_\_\_ NUMBER SECTIONS \_\_\_\_\_ POWER GAIN \_\_\_\_\_

ISOLATION METHOD IF ON AM TOWER \_\_\_\_\_

STATION MONITORING & MEASURING EQUIPMENT (MFG. & TYPE #)

FREQUENCY AND MODULATION MONITOR \_\_\_\_\_ DISTORTION METER \_\_\_\_\_

BEAT FREQUENCY OSCILLATOR \_\_\_\_\_

SPECIAL EQUIPMENT \_\_\_\_\_

AUDIO INPUT EQUIPMENT AT TRANSMITTER (MFG. & TYPE #)

LOCATION OF PRE-EMPHASIS NETWORK \_\_\_\_\_

Distribution: Camden Sales Engineering Production Sales Station Quality

Sheet 24

**RCA SERVICE COMPANY, INC.**  
A RADIO CORPORATION OF AMERICA SUBSIDIARY  
CAMDEN 2, NEW JERSEY

**AUDIO PERFORMANCE R-F POWER OUTPUT**  
for F-M Broadcast or T-V Sound

STATION \_\_\_\_\_ Date \_\_\_\_\_  
Engineer \_\_\_\_\_

CARRIER NOISE  
Power \_\_\_\_\_ Kw., FM level \_\_\_\_\_ DB below 100% Frequency Modulation, AM level \_\_\_\_\_ DB below 100% Amplitude Modulation, 400 cycle ref.  
A-F INPUT for 100% Modulation \_\_\_\_\_ dbm, measured at \_\_\_\_\_, 400 cycle ref.

DISTORTION IN PERCENT (see curve sheet # \_\_\_\_\_)

CPS	50	100	200	400	750	1000	2000	3000	5000	7500	10,000	15,000
100% Mod.												
50% Mod.												
25% Mod.												

FIDELITY (see curve sheets # \_\_\_\_\_)

CPS	30	50	70	100	200	400	750	1000	2000	3000	4000	5000	6000	7000	8000	9000	10,000	12,000	14,000	15,000
A.F. In 100% M. Shifted to 1000 Cycle Reference & Inverted																				
Std. Pre-Emph. Curve (Max.)	0	0	0	0	0.05	0.2	0.5	0.9	2.8	4.8	6.6	8.2	9.6	10.8	11.8	12.8	13.7	15.2	16.5	17.1
Min. Limit		-4	-3.5	-3.0	-2.95	-2.8	-2.5	-2.1	-0.2	1.8	3.6	5.2	6.6	7.8	8.6	9.3	9.9	10.8	11.7	12.1

POWER OUTPUT (indirect)  
Antenna Type \_\_\_\_\_ Gain \_\_\_\_\_ E.R.P. \_\_\_\_\_ Kw., Power to Antenna \_\_\_\_\_ Kw.  
Length T.L. \_\_\_\_\_ ft., T.L. Size \_\_\_\_\_, T.L. Mfg. \_\_\_\_\_, T.L. Loss \_\_\_\_\_ Kw., T.L. Eff. \_\_\_\_\_ %  
Transmitter Output \_\_\_\_\_ Kw., P.A. Eff. (chart) \_\_\_\_\_, P.A. Input \_\_\_\_\_ Kw., Ep. \_\_\_\_\_, Ip \_\_\_\_\_

POWER OUTPUT (dummy)  
Watt meter # \_\_\_\_\_ Output \_\_\_\_\_ Kw., Water Cooled Dummy \_\_\_\_\_ gpm, T in \_\_\_\_\_ °C, T out \_\_\_\_\_ °C.  
Power = 0.263 x gpm x (T out - T in) = \_\_\_\_\_ Kw., Reflectorizer \_\_\_\_\_ uA incident, \_\_\_\_\_ uA reflected.

F-M Broadcast or T-V Sound Sheet No. 2



should be used and is usually incorporated in audio output circuit of the monitor.

4. Repeat steps 1, 2 and 3 on at least the following frequencies: 100, 400, 1000, 5000, 10,000 and 15,000 cycles.

5. Repeat steps 1, 2, 3 and 4 except in each case adjust the audio input for 50% modulation as indicated by the modulation monitor and omit measurements at 10,000 and 15,000 cycles.

6. Repeat steps 1, 2, 3 and 4 except in each case adjust the audio input for 25% modulation as indicated by the modulation monitor and omit measurements at 10,000 and 15,000 cycles.

The distortion should be less than  $3\frac{1}{2}\%$  at frequencies between 50 and 100 cycles, less than  $2\frac{1}{2}\%$  at frequencies between 100 and 7,500 cycles and less than 3% at frequencies between 7,500 and 15,000 cycles.

### Audio Frequency Response Measurements

To make audio frequency response measurements, set up the equipment as shown in Fig. 2. If the pre-amplifier response contains compensation to correct for the microphone response and this cannot be easily removed, the pre-amplifier should be omitted from the circuit. It is recommended that separate response curve be made on the pre-amplifier. Use the same gain settings as were used in making the noise measurements, and proceed as follows:

1. Set audio oscillator frequency to 50 cycles.

2. Adjust the audio input (oscillator output and attenuator panel settings) for 100% modulation as indicated by the modulation monitor.

3. Measure and record the audio level at the input of the pre-amplifier.

4. Repeat steps 1, 2 and 3 on at least the following frequencies: 100, 400, 1000, 5,000, 10,000 and 15,000 cycles in each case re-adjusting the input for 100% modulation.

5. Repeat steps 1, 2, 3 and 4 except in each case adjust the input for 50% modulation.

6. Repeat steps 1, 2, 3 and 4 except in each case adjust the input for 25% modulation.

FIGS. 8a, b, c and d (at right). Performance curves required by FCC. These are typical curves plotted from measurements taken at WFBR-FM, Baltimore, Md.

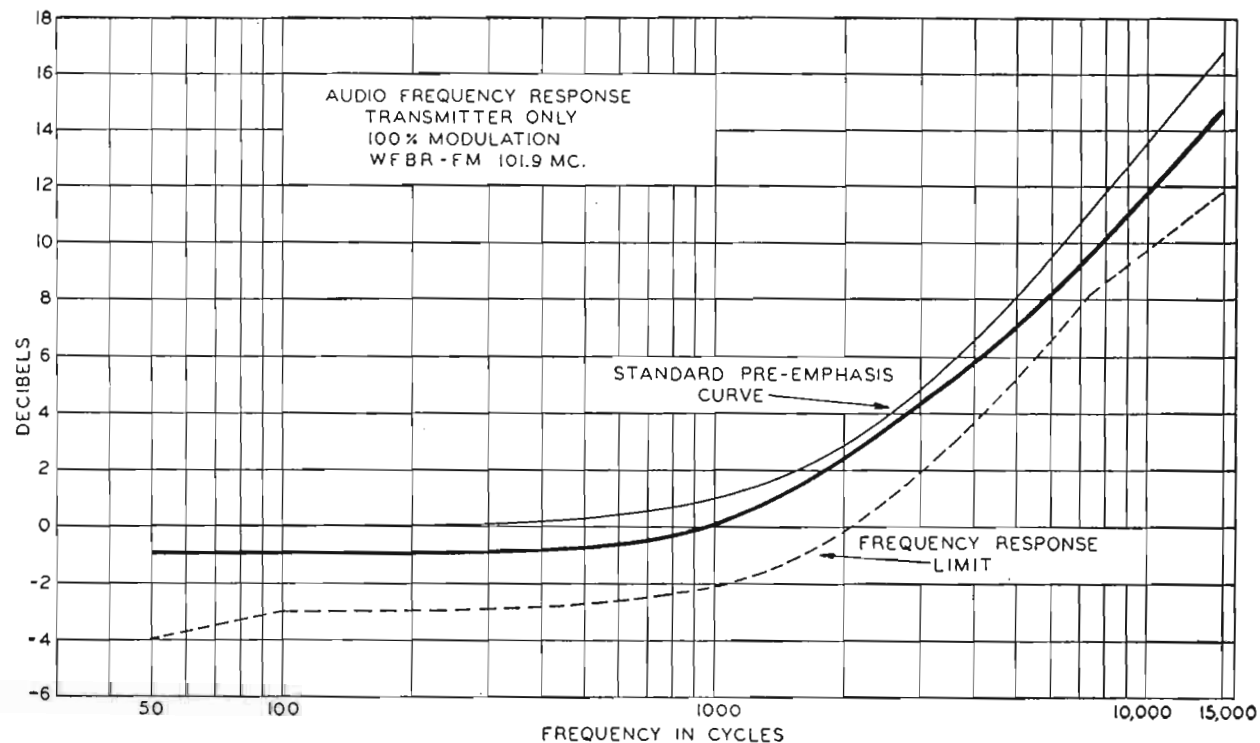

FIG. 8a.

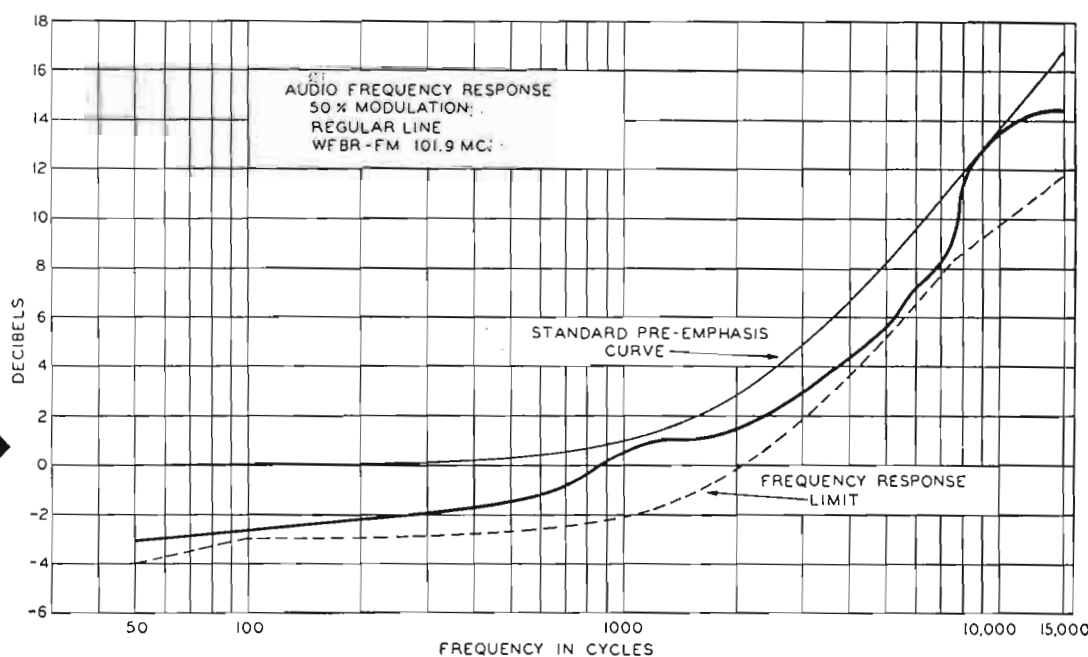

FIG. 8b.

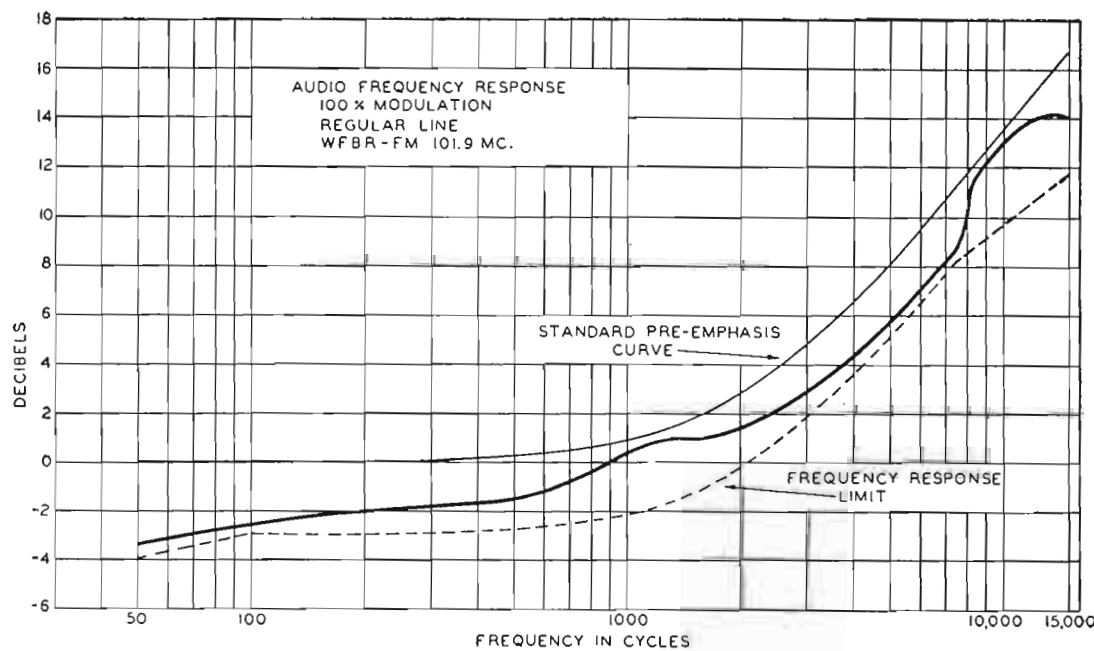
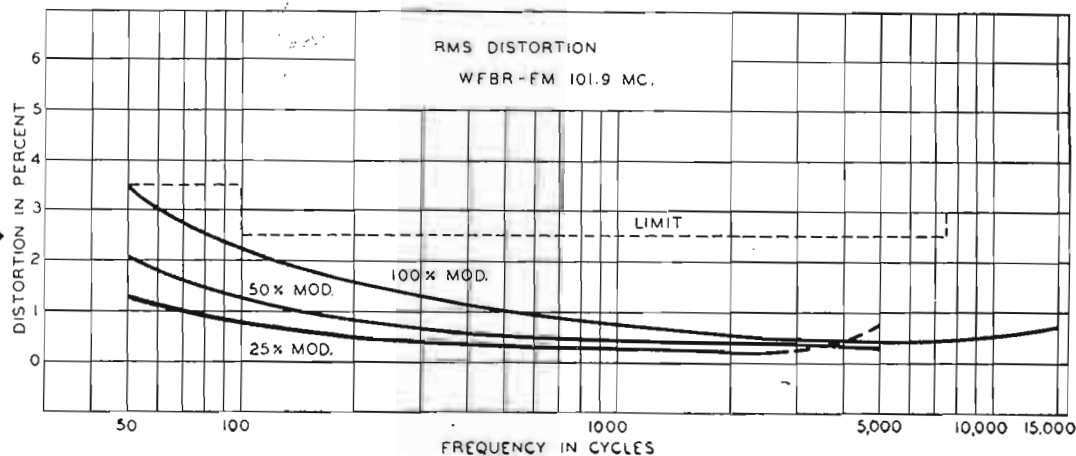

FIG. 8c.

FIG. 8d.



These input readings when subtracted from a suitable reference level should be compared with the standard pre-emphasis curve. To be within the FCC limits it should be possible to plot a curve from this data which, when referred to a suitable reference level, will fall between the standard curve and the lower limit curve shown in Fig. 8a.

### Output Noise Measurements (Amplitude Modulation)

Since it is not practical to amplitude modulate an FM transmitter in order to obtain a reference level for the AM noise measurement, some other method must be found to establish this reference. A method involving a minimum of equipment is described below. Here, we rectify a known part of the RF carrier—measure the actual noise on the detected voltage, and compare that with the calculated voltage\* that would be required to 100% modulate the RF signal at the input of the rectifier. To make the measurement, set up the equipment as shown in Fig. 5. The RF voltage for the rectifier may be obtained from the same source that normally sup-

plies voltage to the modulation monitor. To make the measurement proceed as follows:

1. Increase the RF coupling between rectifier and the transmitter until the rectified d-c voltage (M1 Fig. 3) is 4 to 5 volts.
2. With the noise meter connected to the rectifier, adjust the noise meter for a convenient reference reading of the ripple on the rectified d-c.
3. Connect the noise meter to the output of the attenuator panel and adjust the output of the oscillator and the attenuator settings for the same reading on the noise meter as obtained in step 2. The level indicated by the attenuator panel is equal to the ripple level expressed in dbm.
4. The AM noise level referred to level representing 100% modulation\* can be calculated by the following formula:

$$\text{AM hum level (db)} = 10 \log_{10} \frac{(.707 V_{dc})^2}{.6} + V_r$$

where  $V_{dc}$  = the rectified dc voltage (M1)  
and  $V_r$  = the ripple voltage in dbm

The FCC allows the use of de-emphasis between the rectifier and the V.U. meter.

If there is any appreciable high frequency component to the noise, the use of a de-emphasis network will obviously give lower noise measurements, but since the AM noise is normally made up almost entirely of low frequency hum, it will not be affected by the de-emphasis circuit. Although the de-emphasis is not shown in the circuit of Fig. 3, it may be added provided its insertion loss is taken into consideration when making the calculations.

### IV. DATA REQUIRED BY THE FCC

A copy of the data taken for these measurements, together with curves on distortion and frequency response and brief description of the measuring techniques, should be attached to Form #302 when applying for a license.

There are many ways in which this information can be submitted. The important thing is to make sure that all the data required by the FCC is included. It is suggested that at least the following be included in the report. See typical RCA Service Co. forms of Figs. 6 and 7.

\* The peak voltage required to modulate a carrier 100% is equal to the peak carrier voltage.

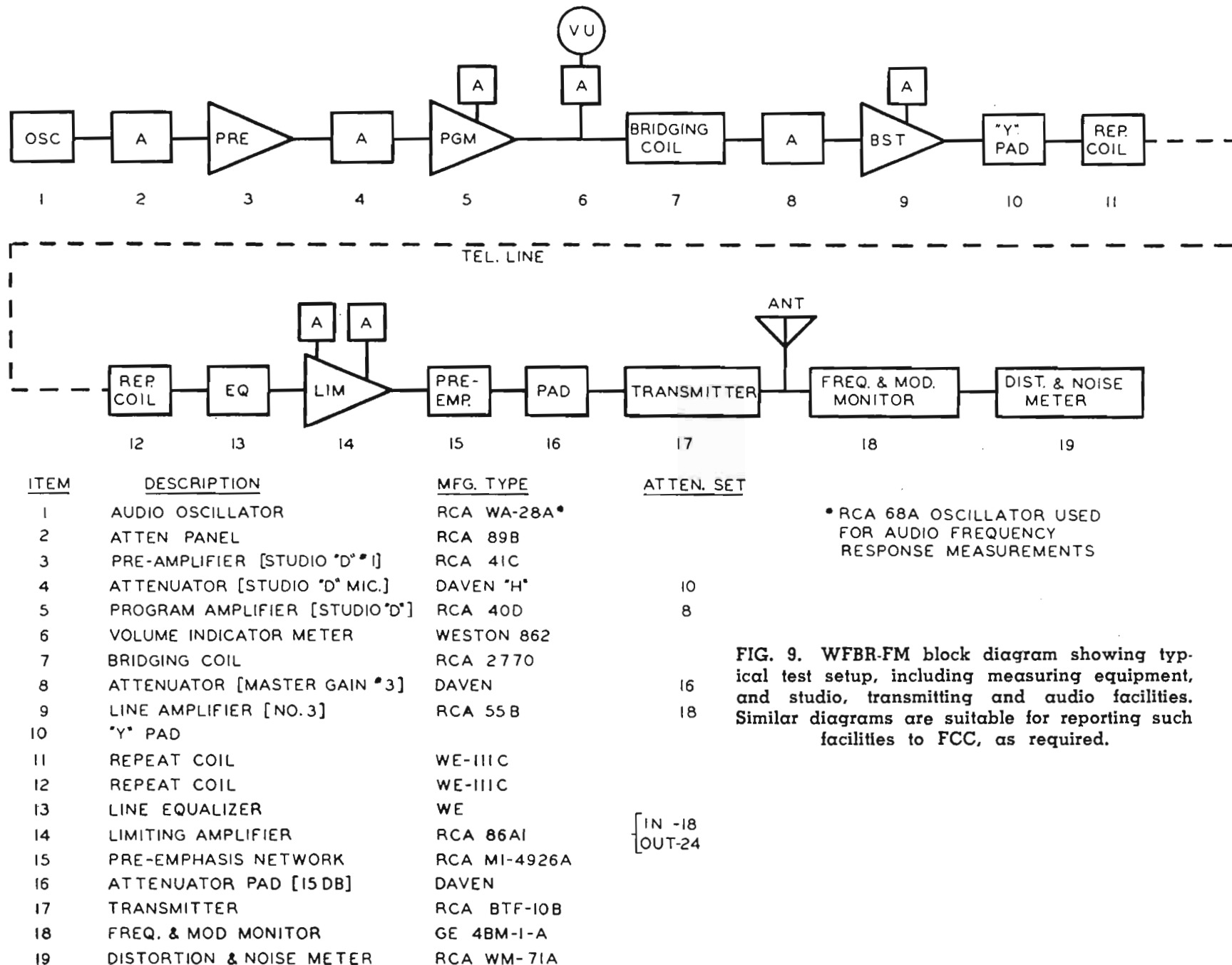

FIG. 9. WFBR-FM block diagram showing typical test setup, including measuring equipment, and studio, transmitting and audio facilities. Similar diagrams are suitable for reporting such facilities to FCC, as required.

1. General information as to the conditions under which the tests were made, such as:

- (a) Date of making measurement.
- (b) PA plate voltage, plate current and grid currents.
- (c) Transmitter power output.
- (d) Effective radiated power.
- (e) Signature of engineer making measurements.

2. Data on audio frequency response measurements.

3. Data on harmonic distortion measurements.

4. Data on carrier noise (frequency modulation).

5. Data on carrier noise (amplitude modulation).

6. The following curves plotted from above data (see Figs. 8a, b, c, and d, for a typical set of curves).

- (a) Overall frequency response at 100% modulation.
- (b) Overall frequency response at 50% modulation.
- (c) Overall frequency response at 25% modulation.
- (d) Overall distortion at 100%, 50% and 25% modulation.

7. Description of measuring equipment, studio and transmitter audio facilities, and measuring techniques. This can best be covered by suitable block diagrams similar to those included in this article and made for WFBR (see Fig. 9), together with any explanatory notes which may be required to make the information clear. A block diagram and description of the method used to measure AM noise should also be included (see Fig. 5).

Although not specifically required by the FCC, it is suggested that, for record purposes, frequency response and distortion measurements be made on the transmitter alone, and that frequency response measurements be made on such items as telephone lines and compensated pre-amplifiers. This information may be very useful at a later date when these proof-of-performance measurements are repeated. Typical curves plotted from data taken at Radio Station WFBR-FM are shown in Figs. 10a, b, c, d, and e.

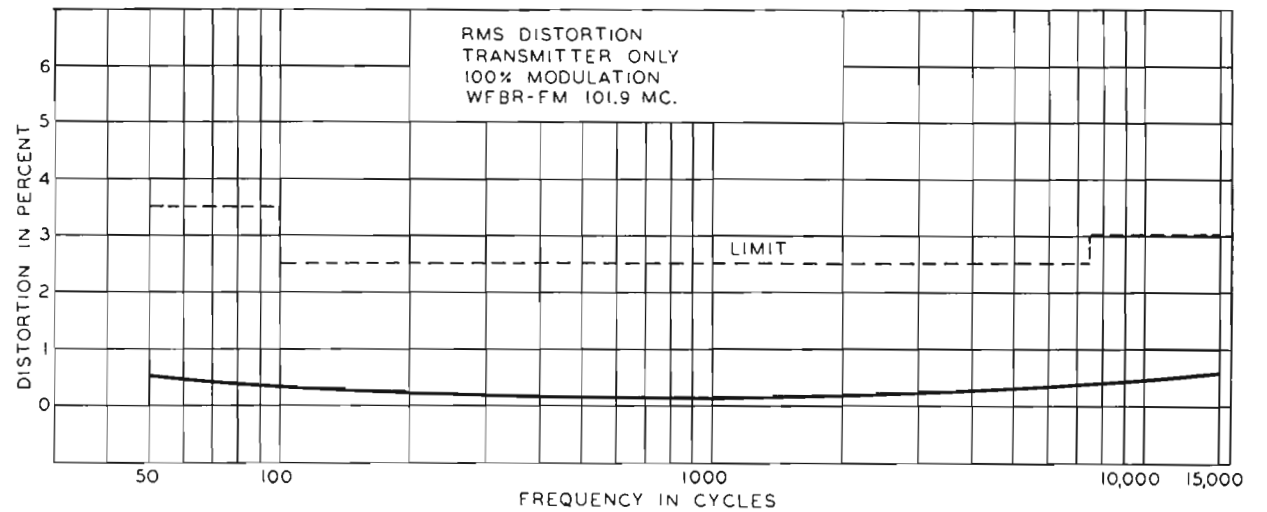

FIG. 10a.

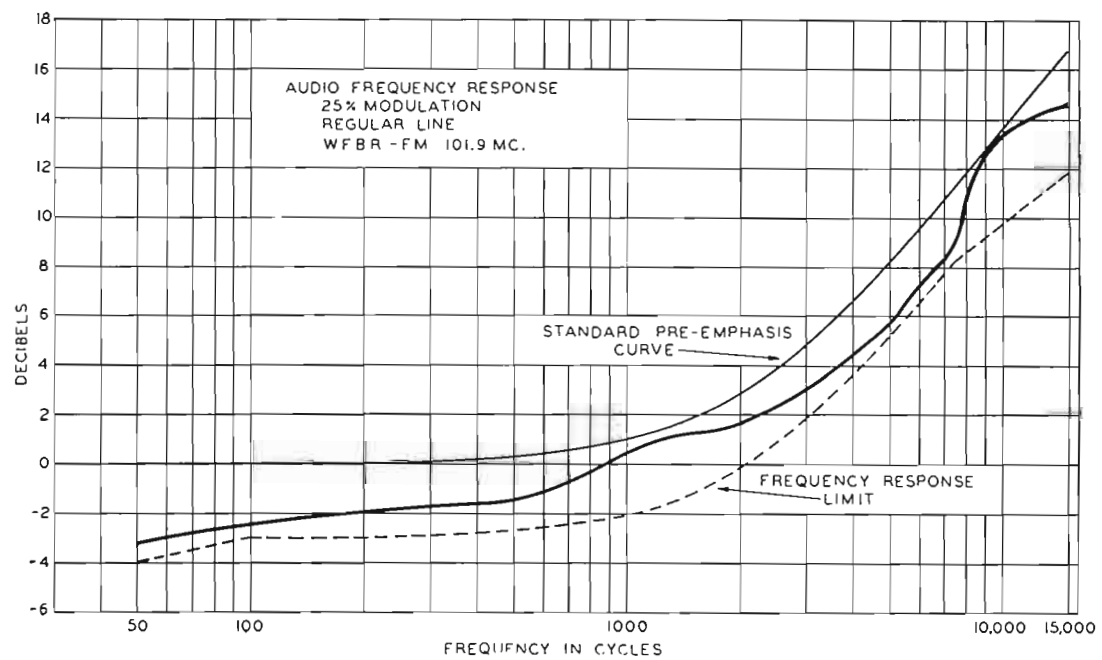

FIG. 10b.

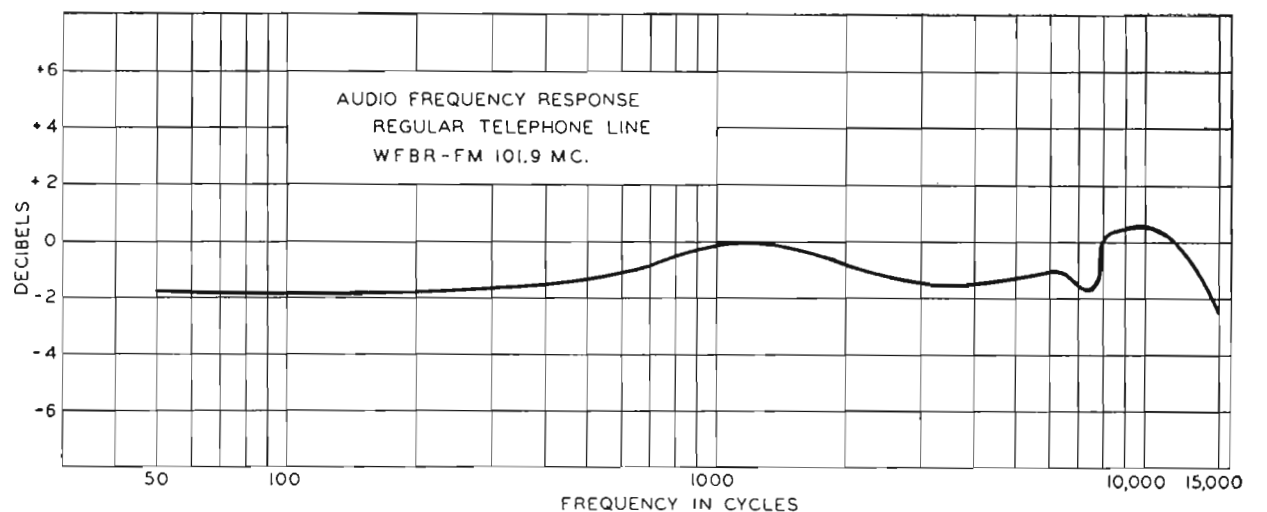

FIG. 10c.

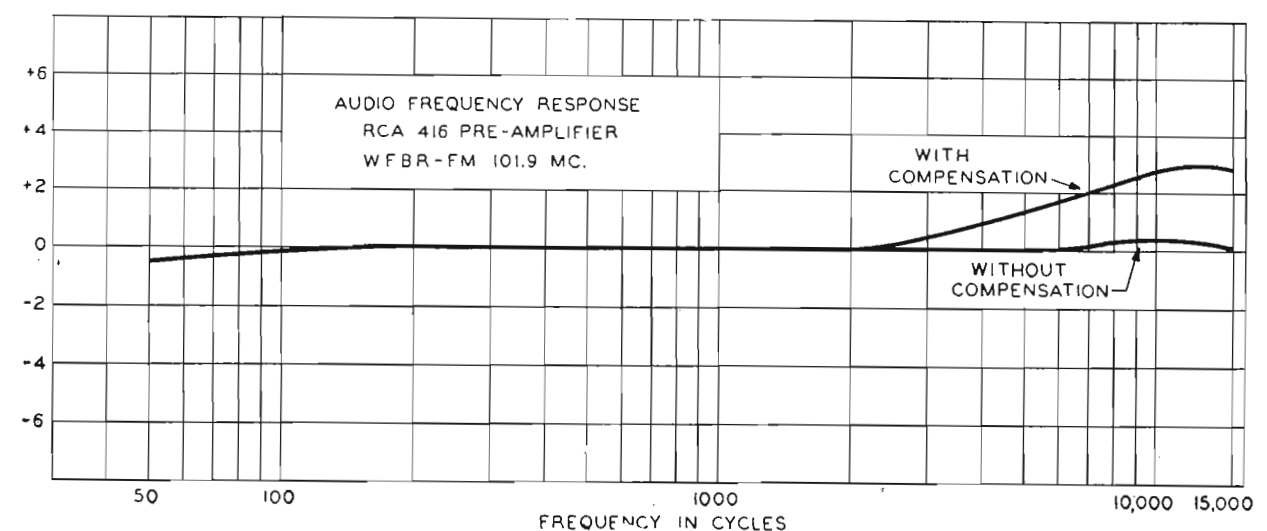

FIG. 10d.

FIGS. 10a, b, c and d (at right). Miscellaneous performance curves made from data obtained at WFBR-FM. While not specifically required by FCC, similar curves are suggested and should prove useful for station reference purposes at a later date.

## APPENDIX NO. 1

### Lists of Measurements Required (Reprinted from FCC Form 302 Section II-B, Paragraph 6)

Attach as Exhibit No. — data, diagrams, and appropriate graphs together with description of measurement procedures and instruments with regard to the following: (See Sections 8 and 13 of the Standards. All measurements shall be made with the equipment adjusted for normal program operations and shall include all circuits between the main studio microphone terminals and the antenna output, including telephone lines, pre-emphasis circuits and any equalizers employed except for microphones, and without compression if a compression amplifier is installed.)

A. Audio frequency response from 50 to 15,000 cycles for approximately 25, 50, and 100 percent modulation. Measurements shall be made on at least the following audio frequencies: 50, 100, 400, 1,000, 5,000, 10,000 and 15,000 cycles. The frequency response measurements should normally be made without de-emphasis, however, standard 75 microsecond de-emphasis may be employed in the measuring equipment or system provided the accuracy of the de-emphasis circuit is sufficient to insure that the measured response is within the prescribed limits.

B. Audio frequency harmonic distortion for 25, 50, and 100 percent modulation for the fundamental frequencies of 50, 100, 400, 1,000 and 5,000 cycles. Audio frequency harmonics for 100 percent modulation for fundamental frequencies of 10,000 and 15,000 cycles. Measurements shall normally include harmonics to 30,000 cycles. The distortion measurements shall be made employing 75 microsecond de-emphasis in the measuring equipment or system.

C. Output noise level (frequency modulation) in the band of 50 to 15,000 cycles in decibels below the audio frequency level representing a frequency swing of 75 kilocycles. The noise measurements shall be made employing 75 microsecond de-emphasis in the measuring equipment or system.

D. Output noise level (amplitude modulation) in the band of 50 to 15,000 cycles in decibels below the level representing 100 percent amplitude modulation. The noise measurements shall be made employing 75 microsecond de-emphasis in the measuring equipment or system.

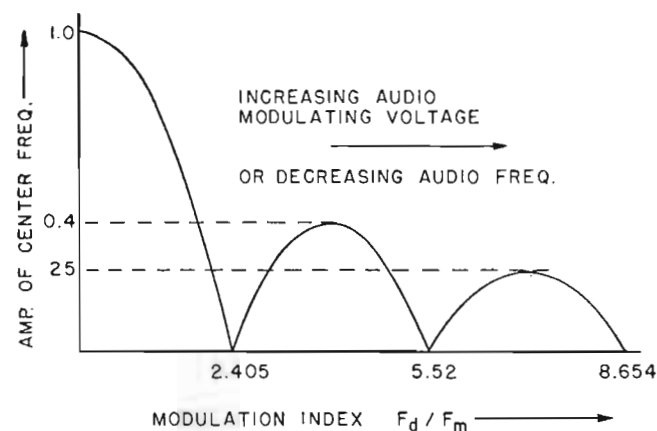

FIG. 11 (above). Center-frequency wave amplitude variation with increasing audio modulating voltage.

FIG. 12 (at right). Test equipment arrangement for determining Bessel Zero Points.

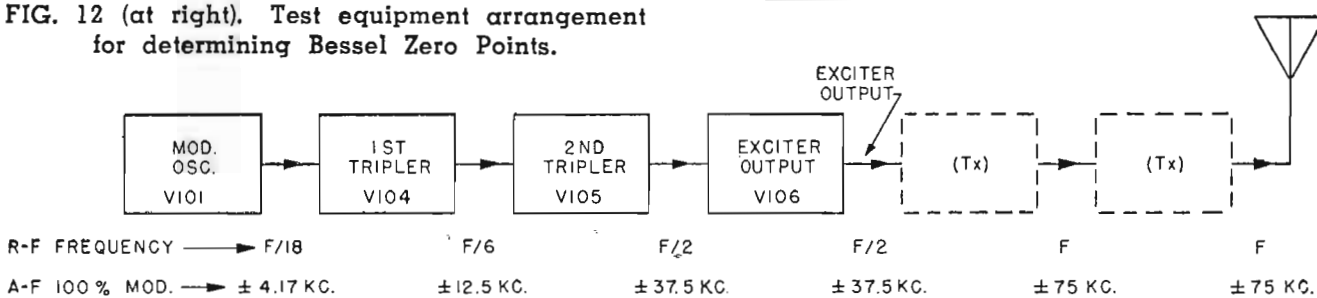

FIG. 13 (above). Exciter block diagram indicating receiver coupling points.

## APPENDIX NO. 2

### FCC Electrical Performance Standards (Reprinted from Section 8 of the FCC Standards of Good Engineering Practice concerning FM Broadcast Stations)

A. Electrical performance standards—The general design of the FM broadcast transmitting system (from input terminals of microphone preamplifier, through audio facilities at the studio, through lines or other circuits between studio and transmitter, through audio facilities at the transmitter, and through the transmitter, but excluding equalizers for the correction of deficiencies in microphone response) shall be in accordance with the following principles and specifications:

1. Standard power ratings and operating power range of FM broadcast transmitters shall be in accordance with the following table:

Standard Power Rating	Operating Power Range
250 watts	250 watts or less
1 kw.	250 watts-1 kw.
3 kw.	1-3 kw.
10 kw.	3-10 kw.
25 kw.	10-25 kw.
50 kw.	10-50 kw.
100 kw.	50-100 kw.

Composite transmitters may be authorized with a power rating different from the above table, provided full data is supplied in the application concerning the basis employed in establishing the rating and the need therefor. The operating range of such transmitters shall be from one-third of the power rating to the power rating.

The transmitter shall operate satisfactorily in the operating power range with a frequency swing of  $\pm 75$  kilocycles, which is defined as 100 percent modulation.

2. The transmitting system shall be capable of transmitting a band of frequencies from 50 to 15,000 cycles. Pre-emphasis shall be employed in accordance with the impedance-frequency characteristic of a series inductance-resistance network having a time constant of 75 microseconds. (See standard pre-emphasis curves.) The deviation of the system response from the standard pre-emphasis curve shall lie between two limits as shown in standard pre-emphasis curves. The upper of these limits shall be uniform (no deviation) from 50 to 15,000 cycles. The lower limit shall be uniform from 100 to

7,500 cycles, and 3 db. below the upper limit; from 100 to 50 cycles the lower limit shall fall from the 3 db. limit at a uniform rate of 1 db. per octave (4 db. at 50 cycles); from 7,500 to 15,000 cycles the lower limit shall fall from the 3 db. limit at a uniform rate of 2 db. per octave (5 db. at 15,000 cycles).

3. At any modulation frequency between 50 and 15,000 cycles and at modulation percentages of 25, 50, and 100 percent, the combined audio frequency harmonics measured in the output of the system shall not exceed the root-mean-square values given in the following tables:

Modulation Frequency	Distortion Percent
50 to 100 cycles	3.5
100 to 7,500 cycles	2.5
7,500 to 15,000 cycles	3.0

Measurements shall be made employing 75 microsecond de-emphasis in the measuring equipment and 75 microsecond pre-emphasis in the transmitting equipment, and without compression if a compression amplifier is employed. Harmonics shall be included to 30 kc.

It is recommended that none of the three main divisions of the system (transmitter, studio to transmitter circuit, and audio facilities) contribute over one-half of these percentages since at some frequencies the total distortion may become the arithmetic sum of the distortions of the divisions.

4. The transmitting system output noise level (frequency modulation) in the band of 50 to 15,000 cycles shall be at least 60 decibels below the audio frequency level representing a frequency swing of  $\pm 75$  kilocycles. The noise-measuring equipment shall be provided with standard 75-microsecond de-emphasis; the ballistic characteristics of the instrument shall be similar to those of the standard VU meter.

5. The transmitting system output noise level (amplitude modulation) in the band of 50 to 15,000 cycles shall be at least 50 decibels below the level representing 100 percent amplitude modulation. The noise-measuring equipment shall be provided with standard 75-microsecond de-emphasis; the ballistic characteristics of the instrument shall be similar to those of the standard VU meter.

## APPENDIX NO. 3

### Bessel Zero System for Measuring FM Transmitter Frequency Swing (Supplied by RCA Service Co.)

#### I. Principle of the Bessel Zero System

1. The purpose of the Bessel Zero System is to provide a means of checking FM transmitter swing without a modulation monitor or for checking the modulation monitor if its accuracy is in doubt.

2. The Bessel Zero method of measurement is based on the fact that the amplitude of the center frequency component of energy, emitted from an FM transmitter, varies with the AMPLITUDE and FREQUENCY of the AUDIO modulating voltage.

During modulation energy is distributed over the frequency spectrum. This diversion of energy to side current frequencies takes center frequency power. The amplitude of the center frequency component is proportioned to the zero order Bessel Function ( $J_0 F_d/F_m$ ).

Fig. 11 illustrates that the center frequency component becomes zero at several points as the audio modulating voltage, and hence frequency swing, is increased.

The point at which the center frequency disappears may be found by listening to the beat note (produced by the center frequency and a beat oscillator) in an AM receiver, as the audio modulating voltage is slowly increased. The deviation may be calculated from the following:

Modulation Index = 2.405

$F_d/F_m = 2.405$

$F_d = F_m \times 2.405$

$F_m = F_d/2.405$

At the first Bessel Zero

$F_d =$  R-F frequency swing to either side of the center frequency

$F_m =$  audio modulating frequency.

3. Bessel Zero Points may be located with the arrangement of equipment shown in Fig. 12.

a. Use a superheterodyne receiver (with a C-W oscillator), or a regenerative receiver.

Note: A crystal filter on the superheterodyne receiver, or a sharp cut-off low pass audio filter in the regenerative receiver may be used to good advantage.

b. Tune the receiver for a beat note of about 500 cycles with the transmitter unmodulated.

c. Modulate the transmitter with the desired audio frequency, by slowly increasing the audio input level (from zero), until the center frequency disappears.

Note: Side frequencies will appear giving many beat notes and the pitch from the center frequency may change. The beat note due to the center frequency must be carefully followed by the ear.

## II. Checking Modulation Percentage (MI-7016 Exciter)

### 1. For First Bessel Zero

Rec. f	$F_d$ KC	% MOD	$F_m$ CYCLES	
F/2	37.5	100	15,600	A-M $R_x$
F/2	28.1	75	11,700	tuning
F/2	18.7	50	7,800	44.0-54.0
F/2	9.4	25	3,900	mc.
F/6	12.5	100	5,200	A-M $R_x$
F/6	9.38	75	3,900	tuning
F/6	6.25	50	2,600	14.6-18.0
F/6	3.13	25	1,300	mc.

$$F_m = F_d/2.405$$

### 2. Procedure

(a) Tune receiver for low frequency beat note with unmodulated frequency indicated.

(b) Set audio oscillator on frequency indicated.

(c) Slowly increase the audio input level until the beat note disappears and then reappears. The percentage of modulation indicated occurs where the beat note disappears.

$F =$  carrier frequency (Transmitter Output)

$F_d =$  frequency deviation

$F_m =$  audio modulation frequency.

### 3. Exciter Block Diagram

Indicating receiver coupling points (Fig. 13).

#### APPENDIX NO. 4

#### Rectifier for Measuring AM Hum and Noise with Built-in Calibration System

Supplied by RCA Test Equipment Design Section

A diode detector suitable for making the AM hum and noise measurements which are required for FCC licensing can be readily constructed with a few parts, all of which are available

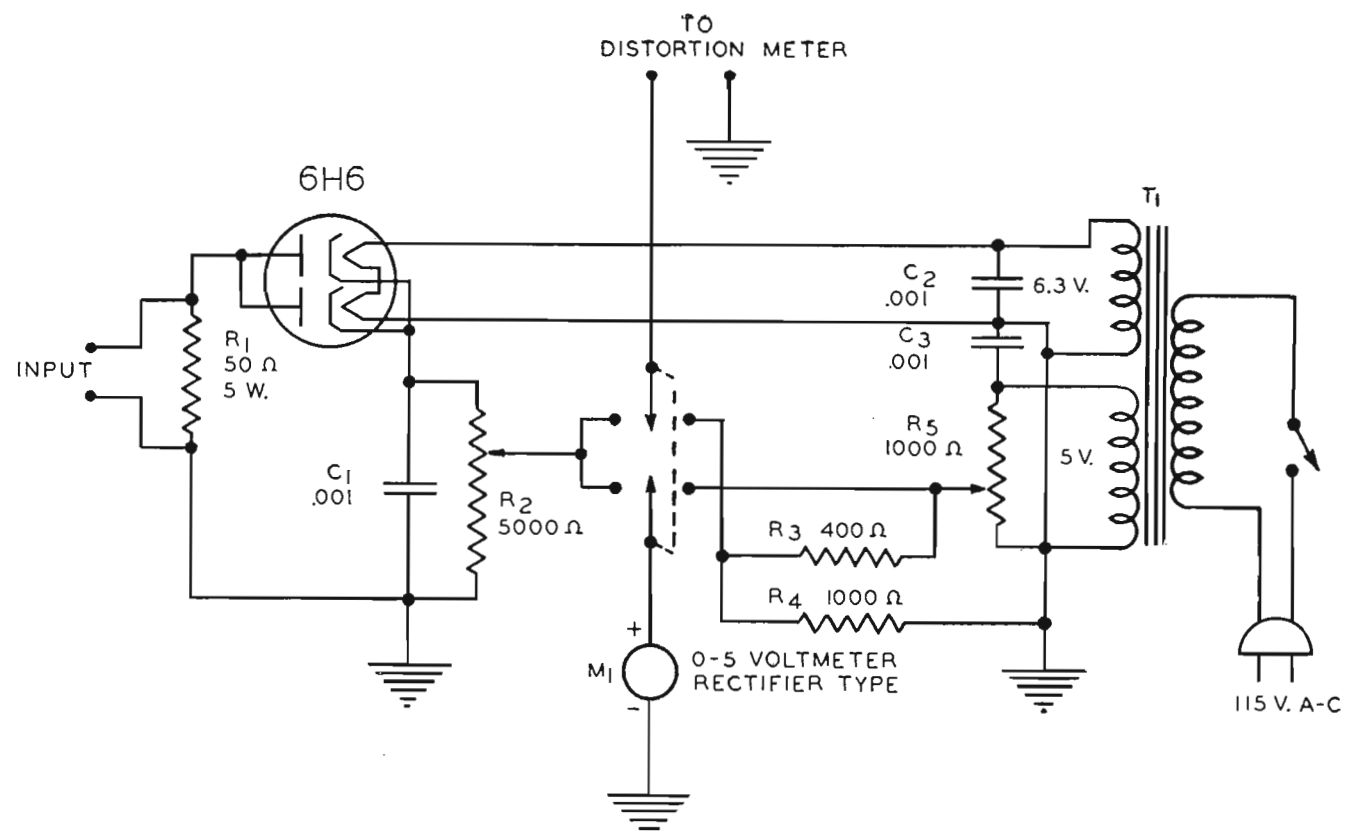

FIG. 14 (above). Schematic diagram for a diode rectifier for measuring AM hum and noise. Note that this equipment will give direct readings when used with any noise meter.

from any radio supply house. A description of such a detector follows:

#### Basic Principles

A schematic diagram is shown in Fig. 14 in order to aid in the explanation of the basic principles.

In an AM transmitter, it is conventional to measure noise level with respect to the amplitude of the modulating signal at 100% modulation. In an FM transmitter, however, the noise is measured with respect to the amplitude of the carrier itself. This is accomplished by providing a source of low frequency a-c with the same amplitude as the carrier and then comparing it with the noise voltage.

The signal is fed into the diode detector. Across the potentiometer will be developed a d-c voltage equal to the peak voltage of the carrier. Superimposed on this d-c will be the noise voltage which is a-c. The d-c voltage is measured by the rectifier type a-c voltmeter, which is connected in such a manner that it will read the d-c output of the diode.

On the opposite side of the equipment is a transformer which provides a source of low value 60 cycle a-c. This voltage may be controlled in amplitude by a potentiometer,  $R_5$ .

It will be observed from the schematic that for any value of a-c which is applied to the meter, only .707 of that value is delivered to the output. This is explained by the fact that the d-c signal voltage is equal to the peak value of the carrier, and it is desired to generate an a-c of exactly the same amplitude but of a low audio frequency. Since the comparing device is the rectifier type meter which reads effective values of a-c, the meter will give the same reading for both d-c signal voltage and a-c voltage only when the a-c is 1.414 times the d-c. However, for the output, a peak a-c which is exactly equal to the d-c voltage is desired. We get this simply by tapping off .707 of the a-c voltage on a voltage dividing resistor.

The noise voltage is then compared with the amplitude of the a-c voltage on the distortion meter.

#### Operation

(a) Introduce R.F. signal from transmitter to input connector. Connect output to distortion meter.

(b) With switch in "Signal" position, increase signal voltage until meter reads in the neighborhood of 3.5 to 4 volts.

(c) Throw switch to "AC" position and increase a-c until meter reads same value as in "Signal" position. Set up distortion meter to read zero db at this level.

(d) Throw switch to "Signal" position and read noise level on distortion meter.

#### APPENDIX NO. 5

#### Tentative RMA Definitions and Standards for Audio Facilities

##### I. Definitions

1.—The *dbm* refers to a single tone (one milli-watt reference).

2.—The *VU* refers to the reading on a VU meter connected across a program line carrying average program.

Note: It is generally accepted that program peaks will be 10 db above the average complex wave reading on the VU meter.

3.—*Audio Frequency Response* shall be expressed in db relative to that at 1000 cycles per second.

4.—*The Audio-Frequency Signal-to-Noise Ratio*, expressed in db, is the ratio between the sine-wave signal power required for *standard output* and the noise power delivered to the rated load impedance of the equipment under test with zero applied signal.

5.—*Audio Frequency Harmonic distortion* is the r.s.s. value of harmonic voltages including at least 2nd, 3rd, 4th, 5th harmonics if within the band of 50 to 30,000 cycles.

$$\text{r.s.s.} = \sqrt{(E_2)^2 + (E_3)^2 + (E_4)^2 + (E_5)^2} \times \frac{100}{E_1}$$

##### II. Standards

1.—*Standard Input Signal* is 2.45 millivolts, RMS in series with 150 ohms; this corresponds to a level of -50 dbm.

2. *Standard Output Level* for facilities feeding telephone lines is +18 dbm (+8 VU).

Note: RMA has specified a standard system gain of 68 dbm. With the output level of +18 dbm into the telephone, input level of -50 dbm is thus specified.

3. *Standard Output Level* for facilities feeding radio transmitters shall be +12 dbm.

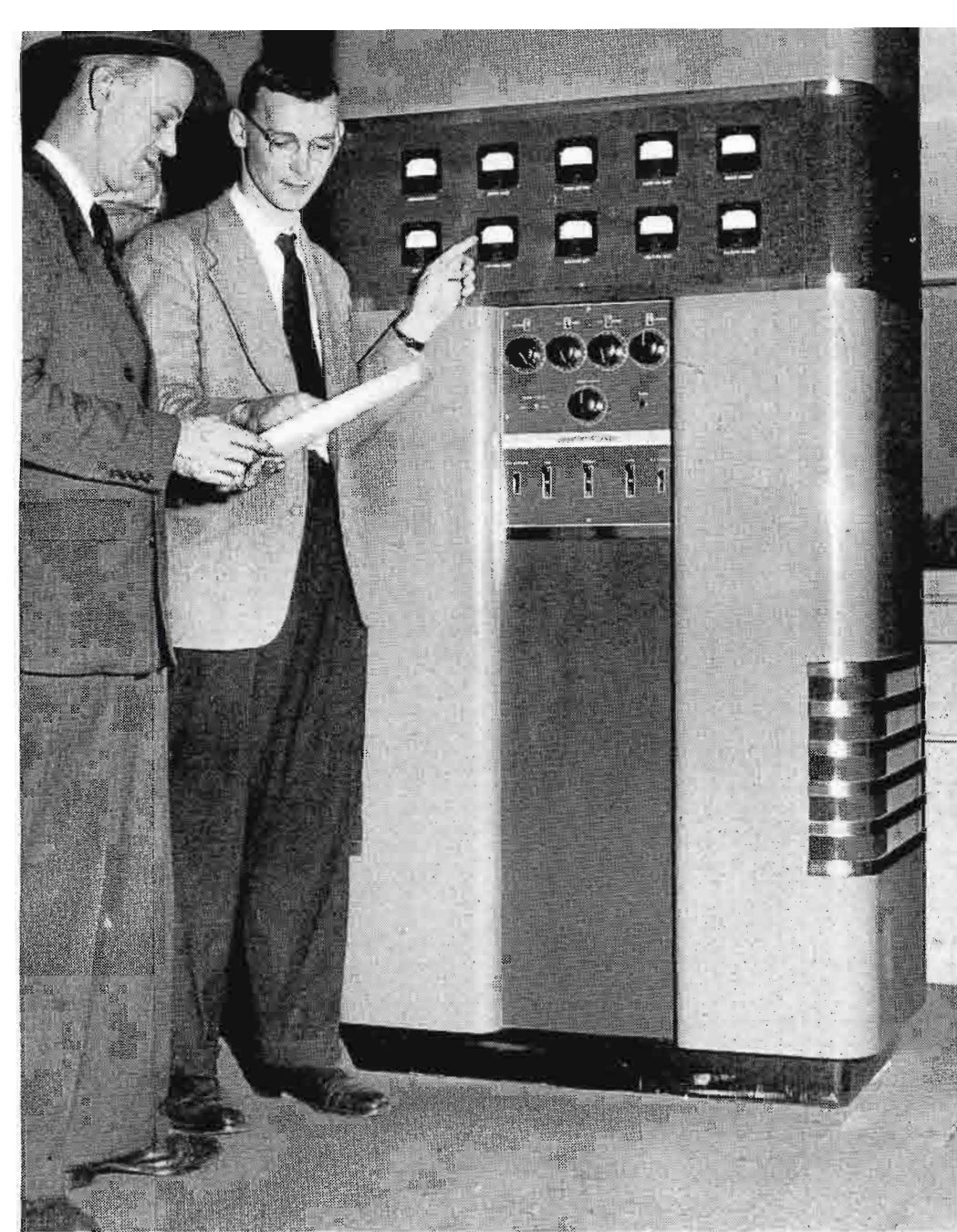

FIG. 1. Chief Engineer Ed Rybak explains meter readings on the RCA BTA-250L to Station Manager Arthur McCracken.

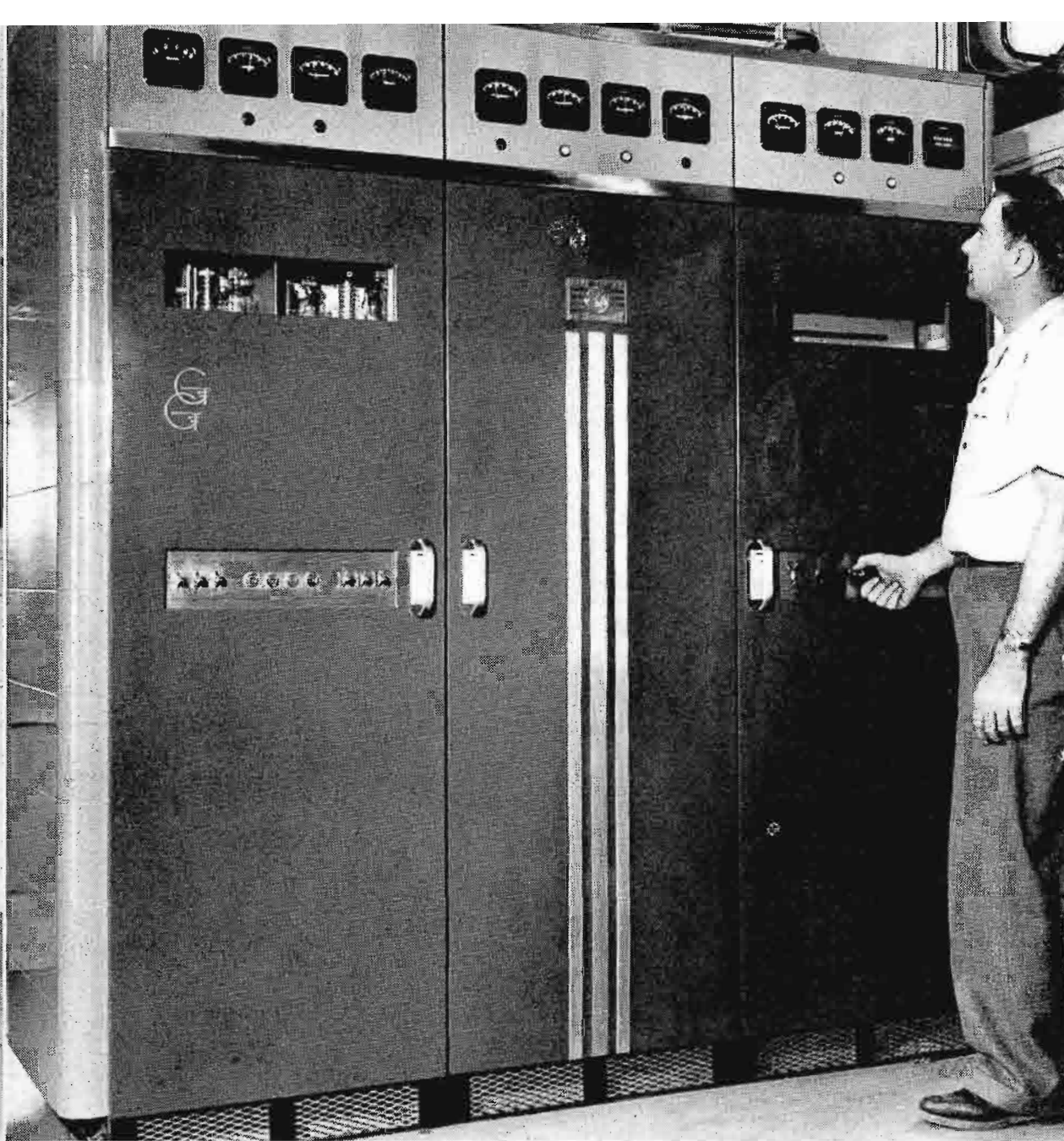

FIG. 2. Checking the BTB-3B is Assistant Chief Engineer Joseph Daday.

# WGPA 250W AM — 3KW FM

## OVERCOME EARLY OBSTACLES TO PROVIDE AM-FM COVERAGE

by  
**ARTHUR McCracken**  
Station Manager, WGPA

Although FM is still expanding and many questions still remain unanswered, the FM future, however, looks excellent. To the novice planning to enter FM or to others already starting construction, some of our problems and their solutions at WGPA, which has been in operation over 18 months, may be interesting.

The Bethlehem Globe Times originally planned only an FM station but subsequent facts proved the advisability of a joint AM-FM operation. To start at the beginning, we engaged very competent engineers and attorneys. Their advice proved invaluable and by working closely with them, many problems were eliminated. The consultant engineers' visit to our community proved its value at a later date regarding the selection of an FM site. His first choice of sites proved to be in the center of air lanes restricting tower heights, but his knowledge of terrain and local

topographical maps aided in selecting an excellent mountain top for good coverage.

To amplify this first problem, deciding on the location was fine, but getting a property was another matter. A visit to an owner of one location with several other men proved to be our undoing. A 10-acre property worth approximately \$2,000 rose to \$5,500. Catching on fast, I started out alone to inquire about land. Incidentally, this requires studying the topographical map for choice locations, and consultations with your engineers. After several inquiries, we were fortunate in finding a farm of 57 acres for ready sale. Most of this was in woodland and purchased for \$5,000. Only about one-third of it is good for farming. Our FM antenna site is not the highest in the area but is more ideally situated for coverage of the entire Lehigh Valley without intervening mountains or rises to create shadows. Following acquisition of the property (through a third party to keep price down) we contacted local power and utility people for service quotations. The power company proved to be the most reliable insofar as being

most definite as to which direction they would approach the site from, and in our case, inquiring as to what our requirements would be regarding power, deviation, etc. Their contract was drawn up and signed and they delivered in true contract style.

Prior to electric service, of course, it was necessary to build a road to the transmitter site. This was about a half mile in length, winding back and forth to the peak. Bulldozers cut this out in about a week at a cost of around \$3,000. Make sure that your road is built wide enough for a good size truck to ascend and that the grade is not too steep to climb. We had contracted for tower delivery on a certain date and, in spite of unusual conditions prevalent at the time, the towers arrived but weather had halted construction of the road. This caused a delay in tower erection and unnecessary loading and unloading of the tower. After finally getting the tower up to the site, some small trouble was encountered in its erection due to the tower base being slightly out of plumb. Jacking it up and resetting plates corrected the trouble. Our tower is specially designed

with a large base spread so that we could erect our transmitter house directly under the tower and within its base. This decreased the amount of coaxial line needed and reduced line loss.

It was at this time that the telephone company started to show some action. There had been previous talks about requirements, viewing of site, etc., but no action had been taken, nor had any contract been submitted. The renewed talks provided the information that no 15,000 cycle per second transmission lines were available. As a result, we operated with only 5,000 cps lines for five months. Only after the telephone company obtained amplifiers capable of 15,000 cps response were we able to give true FM quality and fidelity. An installation of this type entails numerous interviews, viewings, securing private right of way, special contracts for clearing this right of way, and a variety of legal opinions. This is in sharp contrast to the simplicity of obtaining power lines, an order having been all that was necessary.

Equalization of the lines for undistorted transmission of 15,000 cps was the most costly part of this operation. The lines are open wire, with soldered joints; at times, we have experienced some line noise, but it has not proven serious.

Construction of our studios and AM transmitter and tower had meanwhile moved along in orderly fashion. We were on the air with AM on February 8, 1947. Following this, we devoted all spare hours (with an undermanned engineering staff) to the task of getting the FM into operation. Soon after receipt of our 3 KW transmitter, harmonic filters, frequency and modulation monitors, the boys had it in place and ready to go. We were ready to make our first equipment tests March 17th. We started program tests at that time and since have been duplicating all our AM programs (Daytime station only). FM is operated from 7:00 a.m. to 11:00 p.m. We feel this full time operation is justified by reports coming in daily regarding reception. It also enables the dealer and manufacturer to demonstrate the FM set throughout the day or evening. A distributor from a city 40 miles to the west, with 5 counties to serve, reports he uses our stations constantly for demonstration, swinging from our AM to FM to show the difference in quality on the same duplicated program.

Coverage has to some extent been underestimated, since letters have been received from the Chief Engineer of WBCA, Schenectady, the Manager of WWDC, Washington, D. C. from his home in Baltimore, and several from Stamford, Conn.



FIG. 3. Program Director Stefan George interviewing U.S.E.S. employees.

FIG. 4. Preparing the next transcription, Sportscaster Ted Heck works with the RCA control room equipment.



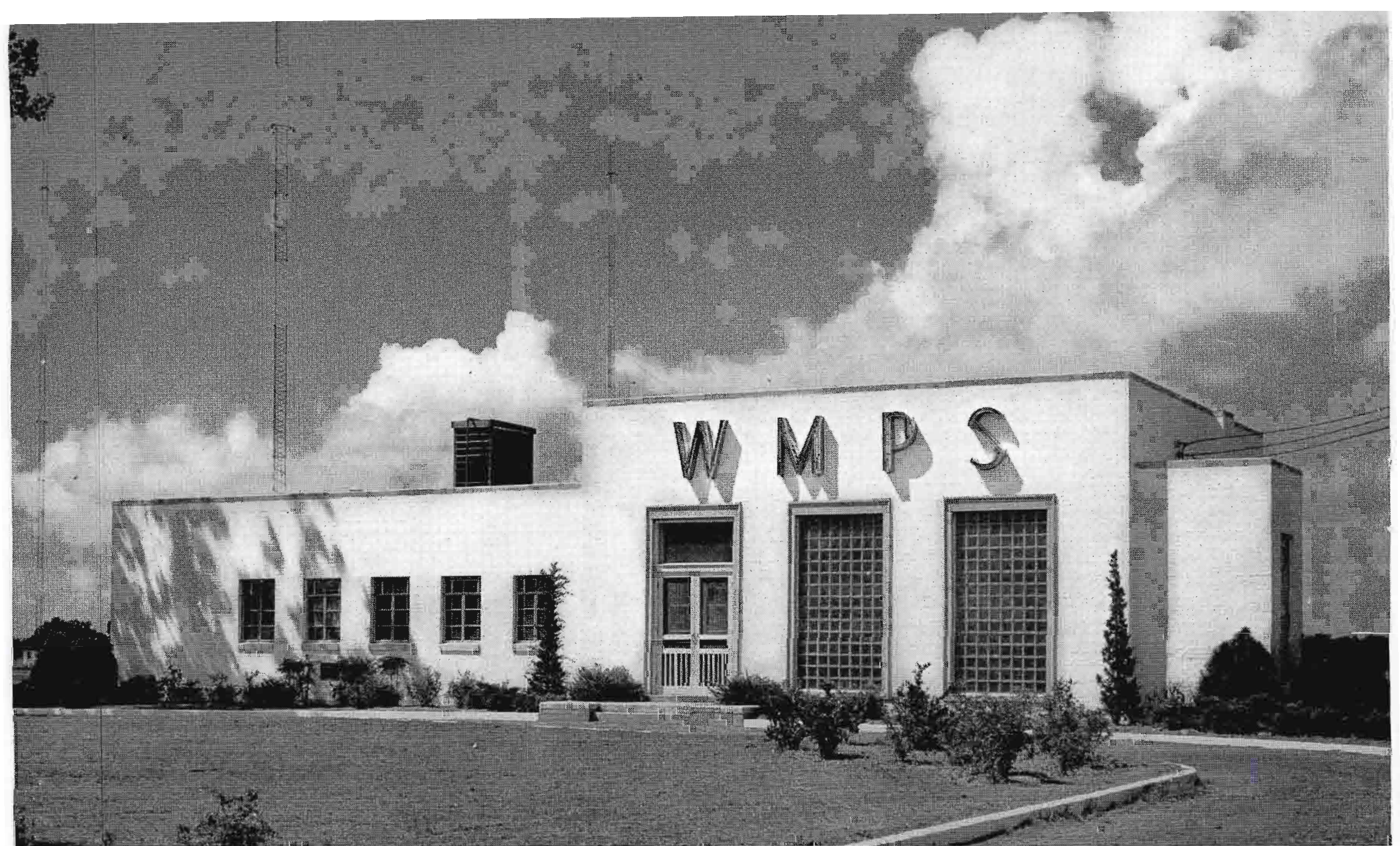

# WMPS . . . MEMPHIS' 10-KW AM

On September 21, 1947 a new era in Memphis radio began when WMPS hit the airwaves with a new frequency and ten times more power. Operating on 680 kilocycles and with 10,000 watts day and 5,000 watts night, WMPS' new transmitter station is an outstanding example of modern radio engineering.

This streamlined "station of the future" is located on WMPS' 163-acre farm on Benjestown Road, a few miles from downtown Memphis. The four 400-foot towers located adjacent to the building are visible for miles.

The transmitter building is of fireproof construction, completely air-conditioned, and houses RCA's most modern 10,000-watt transmitter. To assure uninterrupted broadcasting service, WMPS has purchased a 60,000 watt Diesel auxiliary generator to be used in case of power failure.

## WMPS History

WMPS was born in 1925 when the First Baptist Church of Memphis received its permit to operate a radio station on 1430 kilocycles with studios and transmitter in the Church building, using the call letters WGBC.

In February of 1927 another Memphis radio station that was to be an ancestor of the present WMPS was dedicated. This newcomer was WNBR which also operated on 1430 kilocycles with studios and transmitter located at 883 Poplar Avenue. WNBR and WGBC shared broadcast time, with the Church station broadcasting its services while WNBR beamed news and music to Memphis radio listeners.

WGBC and WNBR were consolidated in 1931 as the Memphis Broadcasting Company using the call letters WNBR and continued to operate on 1430 kilocycles with a power of 500 watts. The same year the station moved into new studios in Hotel DeVoy (now the King Cotton Hotel), and changed its transmitter location to 1690 South Lauderdale to accommodate a new 1000 watt transmitter.

In 1936 the Memphis Publishing Company purchased WNBR and on August 1, 1937 changed its call letters to WMPS. At the same time WMPS moved to its present studio location in the Columbian Mutual Tower. With the purchase of WMPS by the Memphis Publishing Company, the station gained its first network affiliation, becoming the official outlet for

the Blue Network, later the American Broadcasting Company.

On March 29, 1941, WMPS' operating frequency was changed from 1430 to 1460 kilocycles in the world-wide radio frequency re-shuffle.

The present owners of WMPS, Plough Incorporated of Memphis, acquired the station in March of 1945, and immediately started the expansion plans which led to the new transmitter installation. In commenting on the new installation, Abe Plough, President of Plough, Inc., manufacturers of St. Joseph Aspirin, Penetro Nose Drops, and other household necessities, said "A program of progress is the steady goal of the new WMPS." The completion of this new project marks the first step in this program, he added.

## The WMPS Transmitter

Credit for planning and supervising WMPS' expansion program goes to Harold R. Krelstein, Vice-president and General Manager of WMPS. The erection of the building and towers, and the installation of the equipment, was carried out under the supervision and direction of Joe



FIG. 1. Radio Station WMPS is housed in this modernistic building located four miles outside of Memphis, Tenn. The building provides adequate space for two transmitters, an emergency power plant, a well-equipped workshop, living quarters, and a kitchen.



FIG. 2. The station is as neat looking inside as outside. Shown at right is the transmitter room which contains a 10 KW RCA Type BTA-10F Transmitter, a 1 KW BTA-1L Standby Transmitter, the speech input equipment, and the operator's control console.

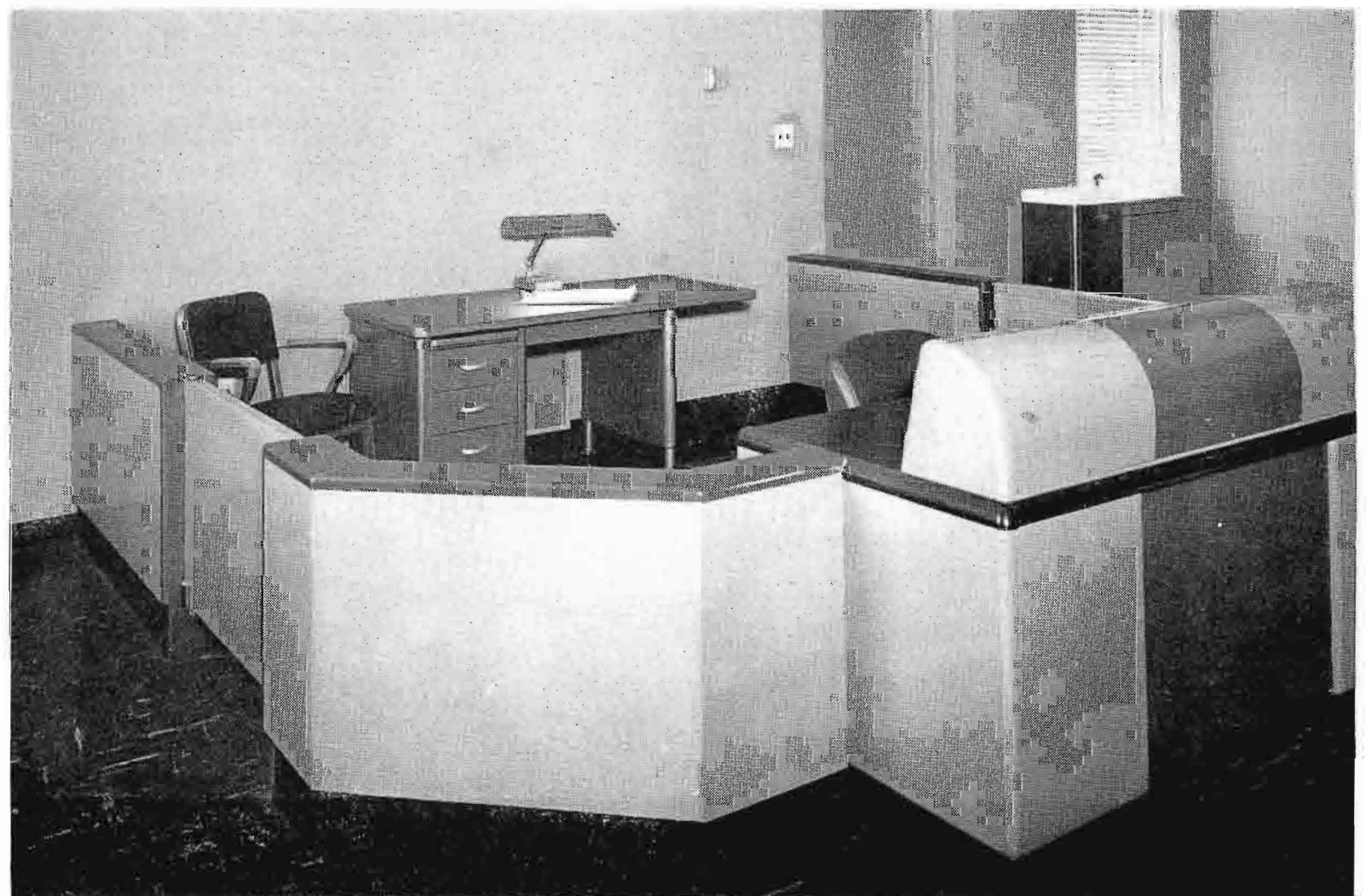

FIG. 3. The operator's console is enclosed on two sides by a low fence giving the enclosure the atmosphere of a private office. A modern desk serves as a convenient place for the operator to fill out the station log.

Deaderick, Chief Engineer. Joe and a crew of nine engineers spent eleven months completing the \$250,000 plant of which they are suitably, and justifiably, proud.

The WMPS transmitter building is a commodious streamlined structure of white-painted brick. Lines of the building are simple, but good proportioning gives it an attractive modernistic look. Space is provided not only for the main and emergency transmitters and accessory equipment, but also for a well-equipped work shop, living quarters including kitchen, and a diesel-driven emergency power supply unit.

The equipment in the WMPS transmitter room includes: (a) an RCA BTA-10F transmitter which is operated at 10,000 watts daytime and 5,000 watts (directive) nighttime; (b) an RCA BTA-1L transmitter for 1,000 watt emergency operation, and (c) a very complete setup of RCA speech input, monitoring and test equipment. The main units are arranged in the form of a shallow-U and are built into drop walls so that there is a totally enclosed space behind the equipment on three sides of the room. The BTA-10F Transmitter is mounted in the center. On the left is the BTA-1L Emergency Transmitter and on the right the cabinet type racks containing the audio, monitoring and test equipment.

At the center of the U formed by the main equipment units is the control console. A low fence around the control area is a unique feature of the transmitter room.

WMPS' antenna array consists of four guyed towers arranged in a square. The main phasing equipment is built into the extreme left panel of the BTA-10F Transmitter. This enclosure is a standard RCA unit designed to be added to this transmitter where phasing equipment is required. The far right panel of the transmitter is a similar enclosure behind which are mounted two standard racks containing audio and monitoring equipment. The use of these "wing" enclosures greatly enhances the appearance of the installation as these views of WMPS illustrate.

That modernity, functionalism, and good-appearance can be achieved without fancywork, and without undue extra expenditure, is certainly proven by this beautiful and well-engineered installation. Orchids to the management that planned it and the engineering staff that carried it out.



FIG. 4. Above is the 1 KW RCA Type BTA-1L emergency standby transmitter. The unit is mounted flush in a drop wall. Doors on either side permit easy access to the rear of the transmitter for servicing.

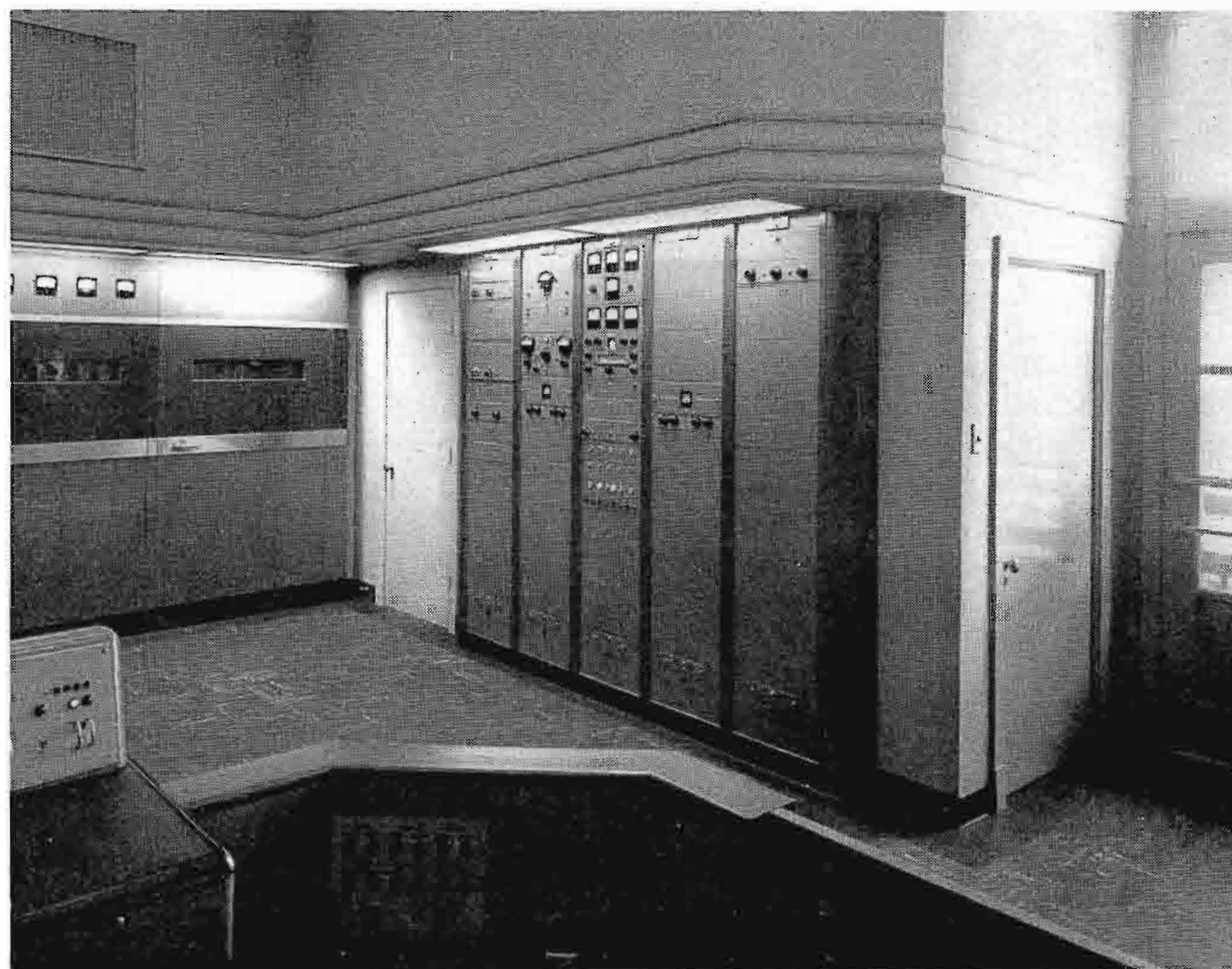

FIG. 5. The cabinet-type racks of audio input, monitoring, and test equipment are flush-mounted in a drop-wall as shown above. This type of construction gives the room a unified appearance and provides ample working room behind the equipment.

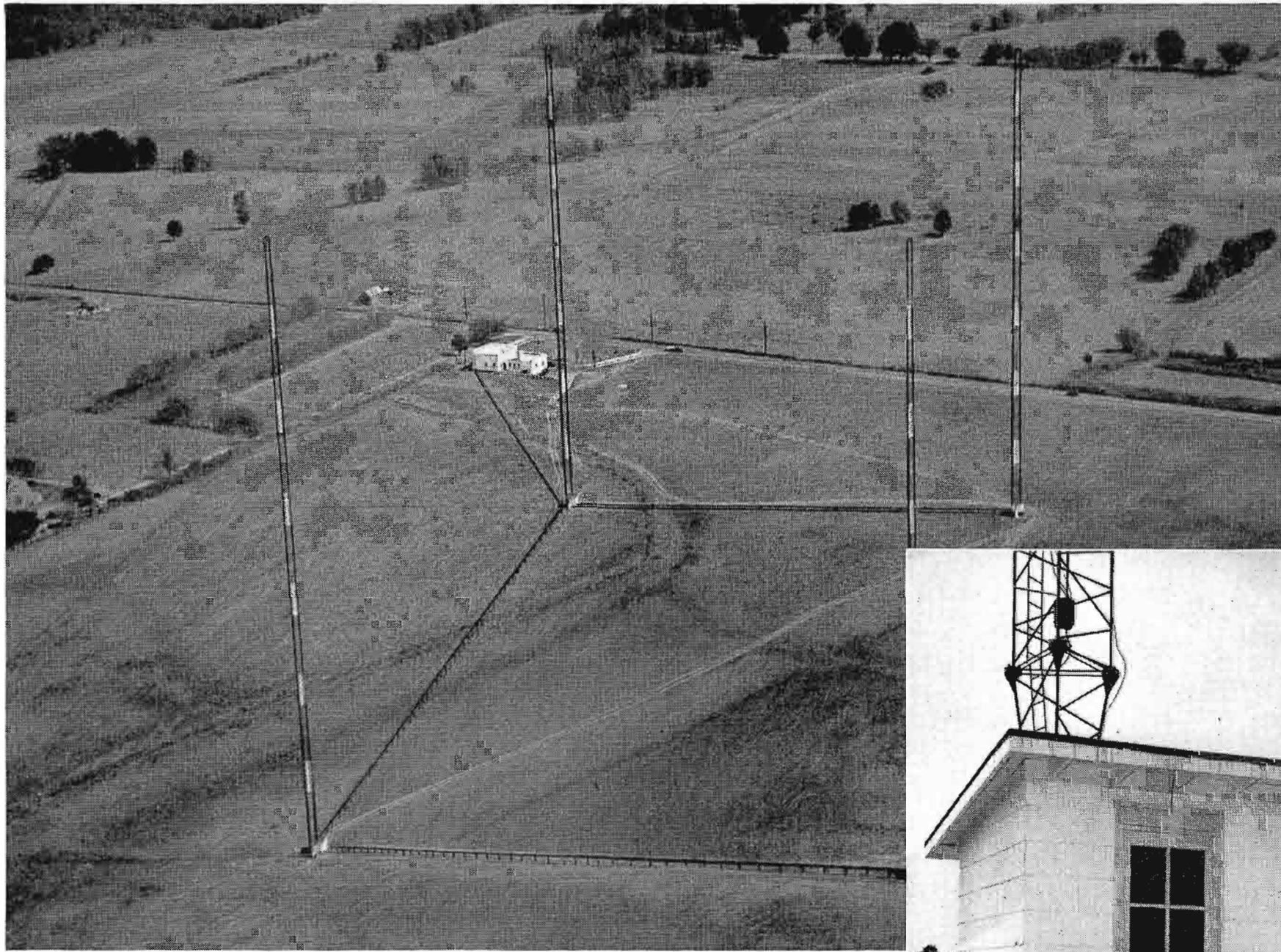

FIG. 6. Four guyed 400-foot towers arranged in a square make up the station's directive antenna array. Phasing equipment for the towers is housed alongside the 10 KW transmitter in a matched panel. The enclosure is standard RCA equipment which is added to transmitters when phasing equipment is employed. Inset shows one of the tower houses located at base of each antenna tower.

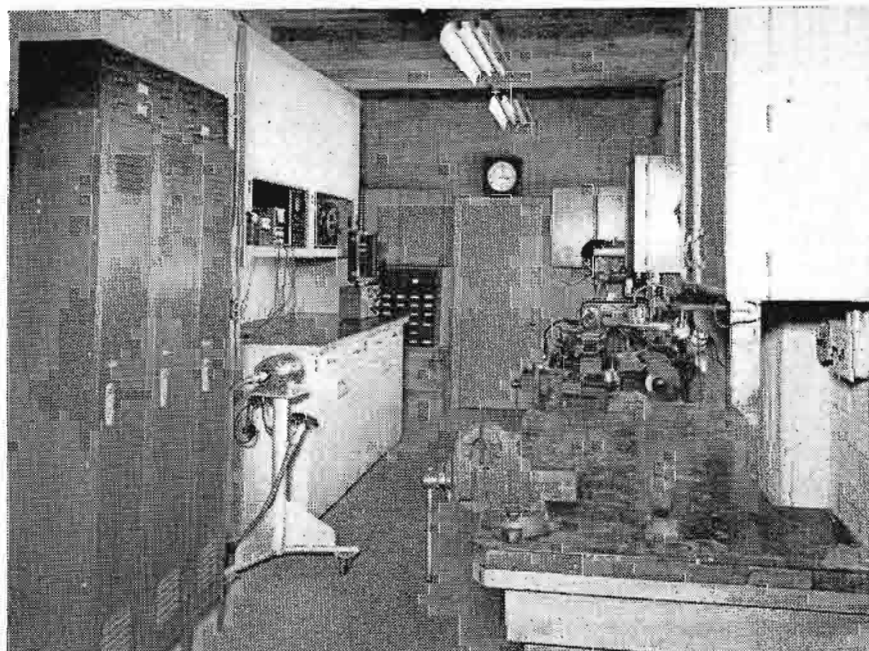

FIG. 7. Photo above shows the well-equipped workshop of WMPS which is outfitted with lathe, and other power tools.

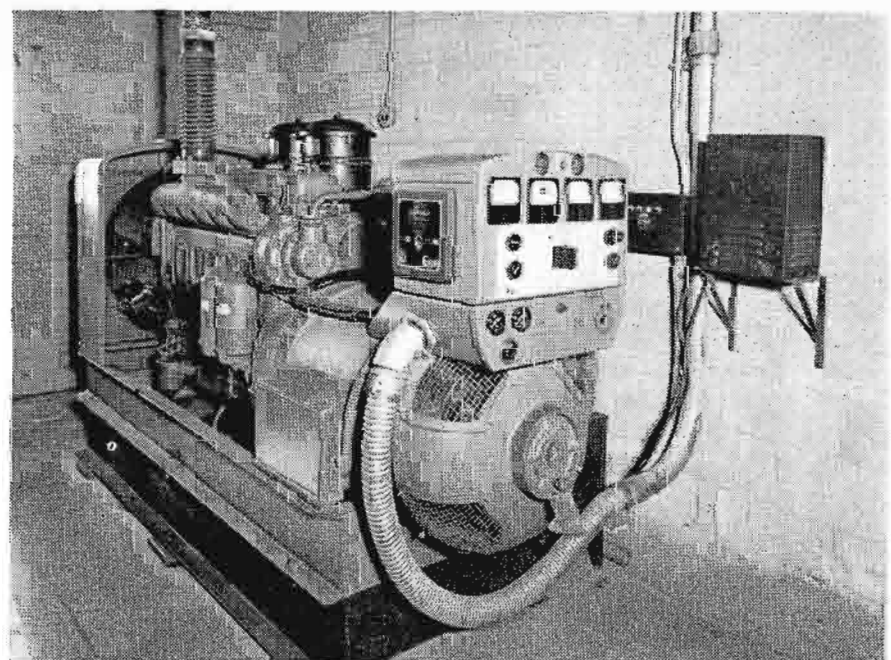

FIG. 8. To insure uninterrupted broadcast service, WMPS installed this 60 KW Diesel auxiliary generator for use in case power fails.

# AN IMPROVED LACQUER DISK RECORDING HEAD

by H. E. ROYS

Audio Engineering Section  
Engineering Products Department

## Introduction

Where speech or music is recorded for direct playback, slight variations in frequency response (in the order of two or three db) are not easily detected and are therefore relatively unimportant. However, for recordings such as masters, which are to be processed, or to be used for re-recording, slight changes in response become objectionable and must be minimized. Flat amplifier response is usually easily obtained, but flat cutter response is more difficult since the components of an electro-mechanical system are not as readily controlled as those of an electrical network. Adequate corrective filters can be designed, however, leaving problems of temperature changes, stylus loading, and changes in the medium, after cutting, due to cold flow or springback. Stylus loading has been investigated with the aid of the FM calibrator<sup>1</sup> and the magnitude of variation is not believed to be excessive for most applications. The problem of variation with temperature has been investigated, and improvements, in addition to ease of maintenance of frequency response, have been noted which have made it desirable to incorporate temperature control in the MI-11850-C recording head.

## Recording Head Design

In many recorder designs<sup>2</sup> the moving system has compliant members between the mass elements which permit them to vibrate in different phase relations at the higher frequencies and so act as separate

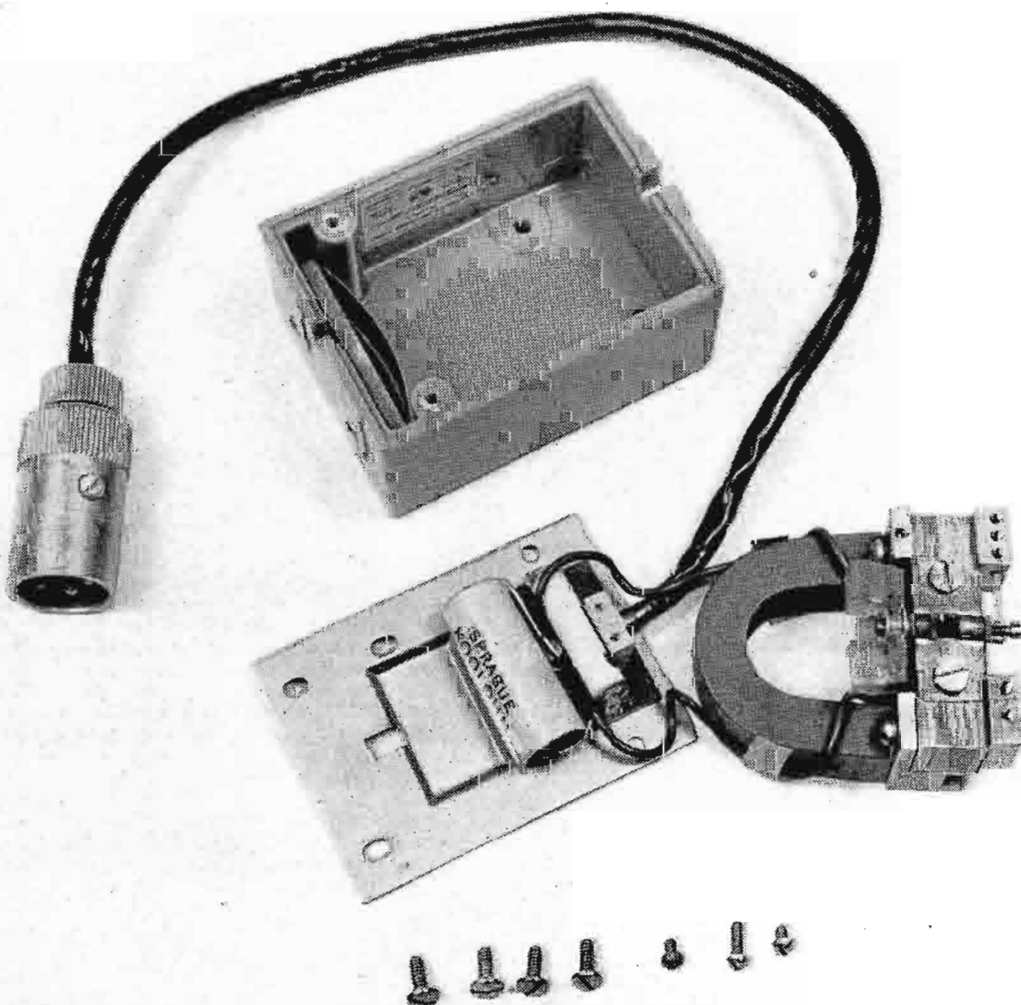
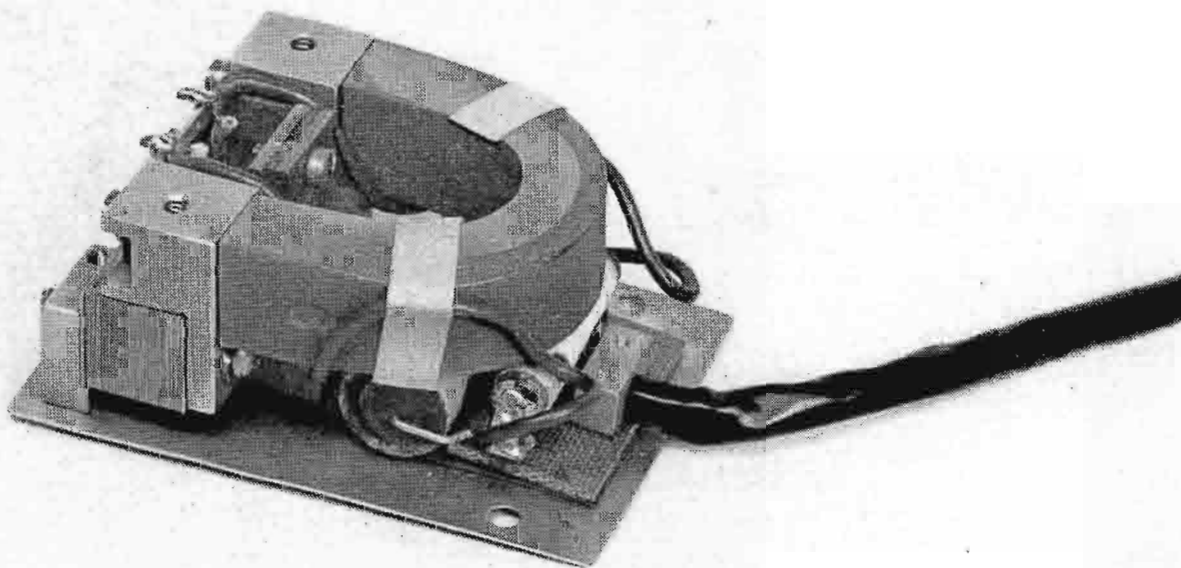
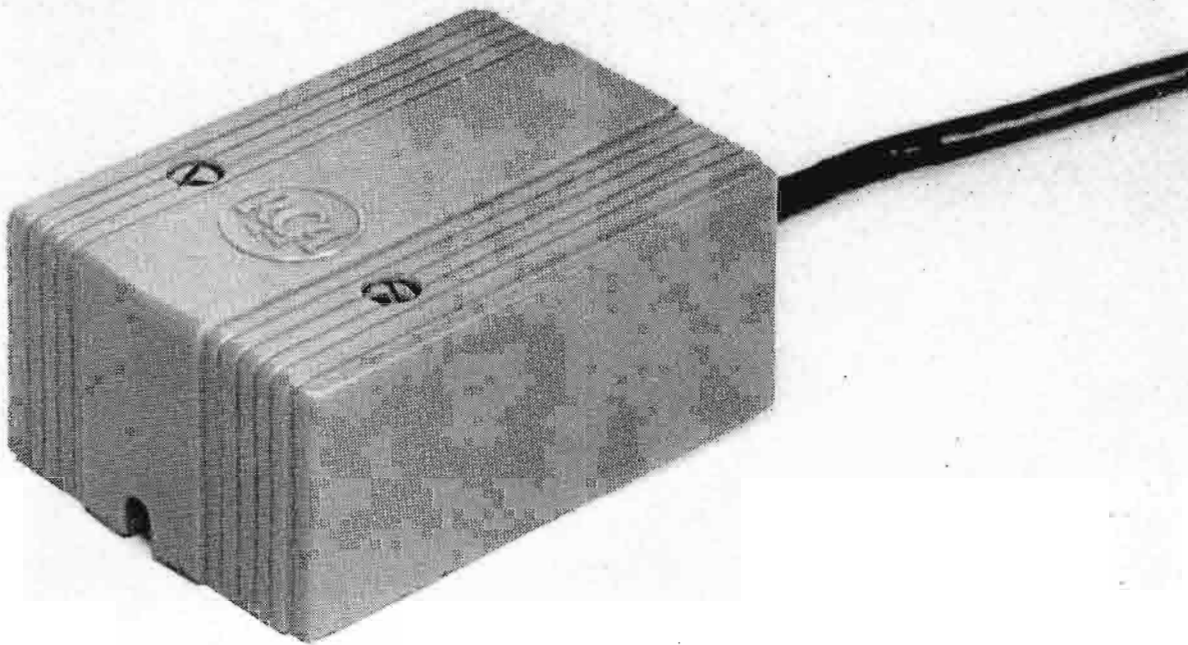

FIG. 1a (at top). MI-11850-C Recording Head.

FIG. 1b (center). Heater Assembly Mounted in Place on the Recording Head.

FIG. 1c (at left). Recording Head, and Heater Assembly Outside of the Case.

masses. As a consequence, there is an effective reduction in mass at the higher frequencies which results in an increase in sensitivity and a wider frequency range. The RCA lacquer disk recording head MI-4887 as originated by Mr. H. J. Hasbrouck<sup>3</sup> was designed utilizing such principles and these are retained in the MI-11850-C. By properly proportioning the masses and compliances, a mechanical arrangement analogous to the electrical network of a low-pass filter is obtained (see Fig. 2). As in the case of the electrical filter, the correct terminating impedance is necessary in order to obtain a smooth transmission characteristic. The termination impedance for the cutter consists of a semi-hard plastic material known as "viscoloid" which exhibits good mechanical damping properties. The magnitude of the damping that is required to flatten the resonance peaks and give a smooth response characteristic is considerable, but this is an advantage as changes in loading while cutting will then have little effect upon the recording characteristic. The ideal case would be to have the mechanical impedance of the recording head so great that its response due to stylus loading while cutting wax or lacquer would be unaffected.

Unlike electrical resistance, true mechanical resistance is difficult to obtain. Utilization of the viscous properties of oil is a means often resorted to in obtaining mechanical damping. The viscous properties of oil change with temperature to such an extent that it is necessary to change to a lighter grade of oil in automobiles at low temperatures encountered during the winter months. Therefore it does not seem unlikely that other damping media such as viscoloid or rubber-like substances which are used in pickups and cutters also exhibit some change in characteristics with temperature when closely examined. The FM calibrator allows measurements of stylus motion within a few tenths of a db and has permitted a study of such variations with an ease and degree of accuracy not available heretofore.

### The Heating Problem

From the heating standpoint we have a large mass of metal which does not require heating and a small block of damping material that does, all mounted in a thin walled plastic case. To surround the entire unit with heat-insulating material to maintain all of the parts at a uniform temperature would result in a large, bulky, impractical unit. It was believed that by mounting the heater between the damping

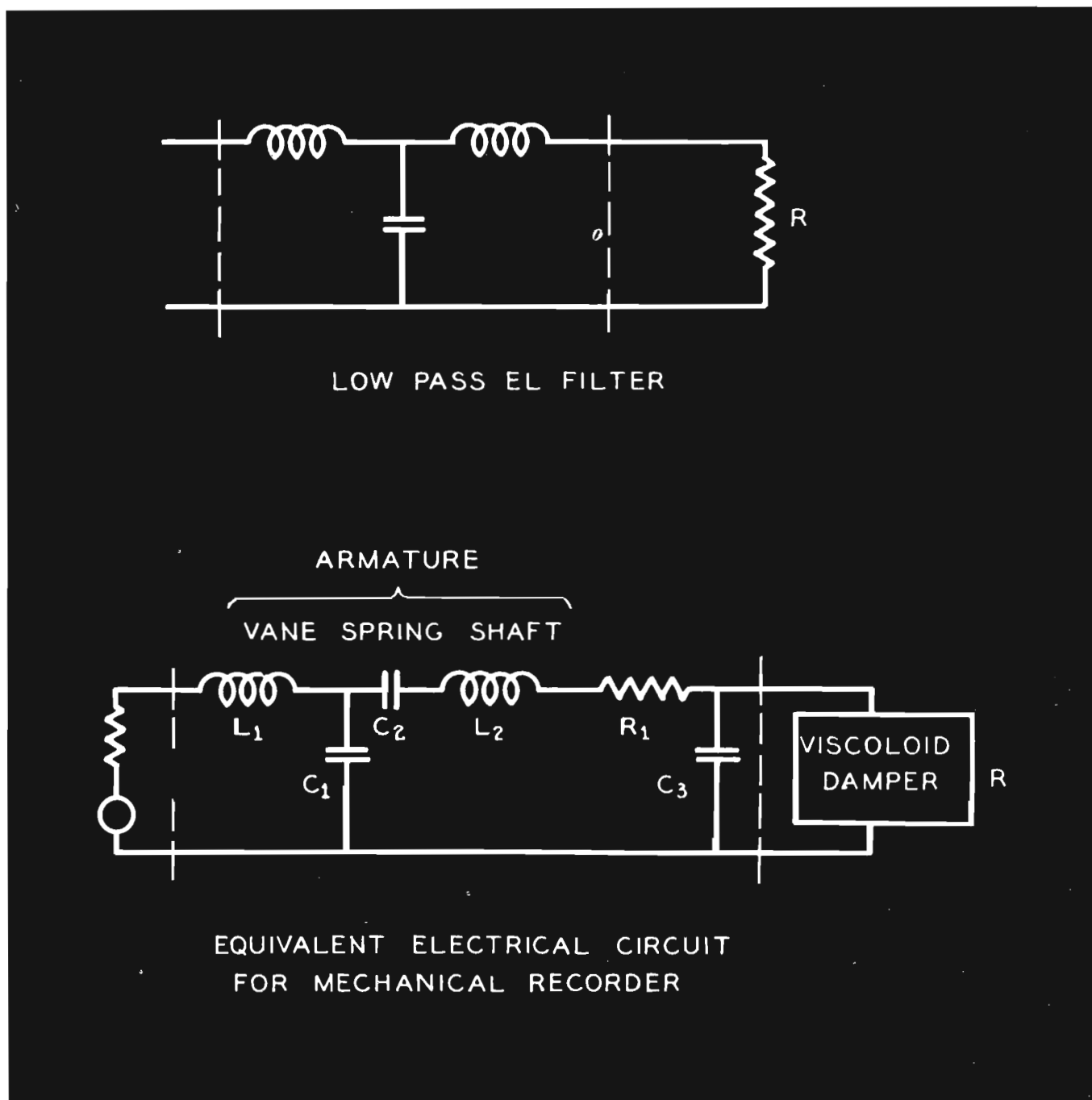
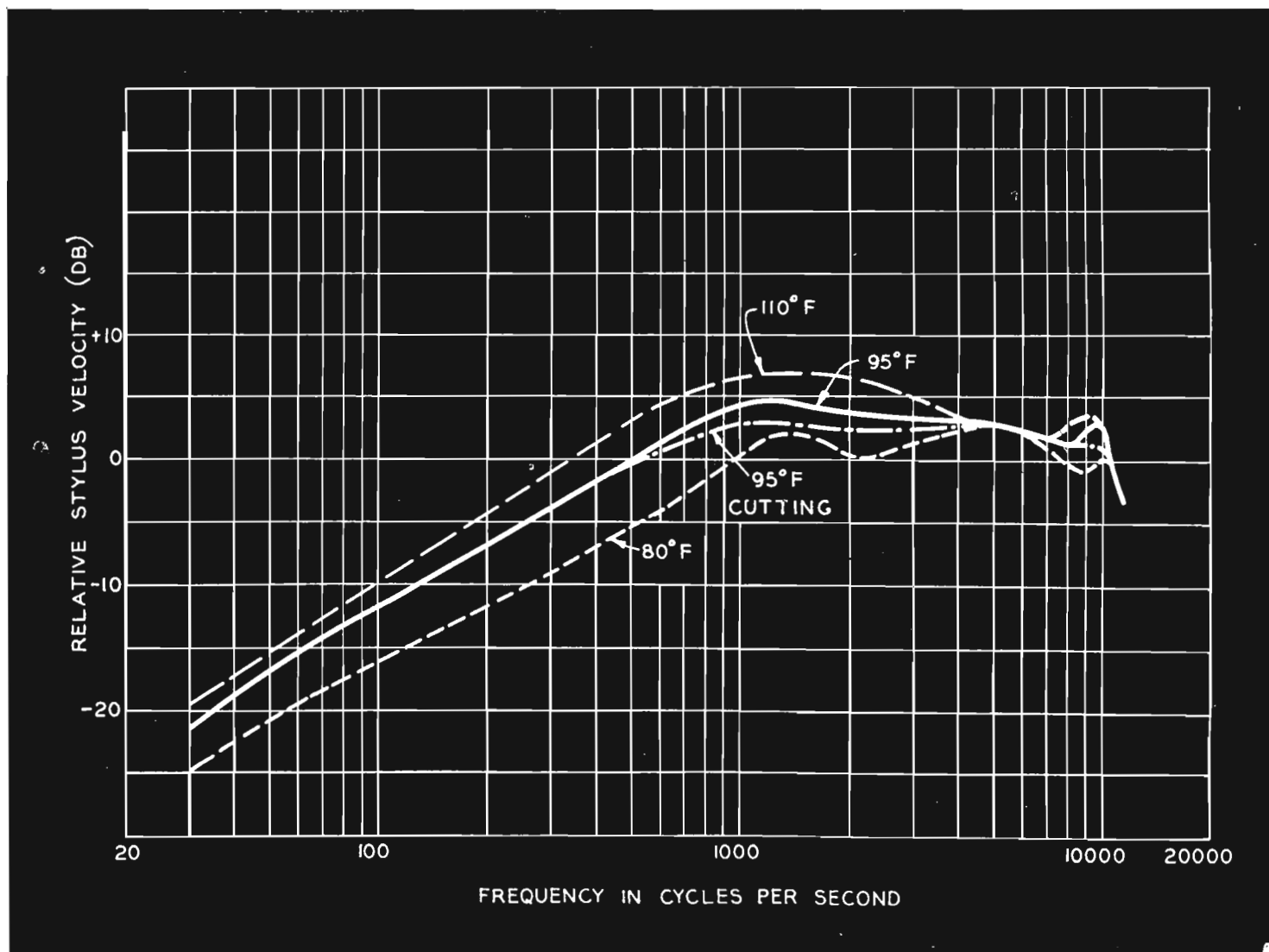

FIG. 2a. (Above) Low-Pass Electrical Filter.

FIG. 2b. Equivalent Electrical Network for a Mechanical Recorder.

FIG. 3. (Below) Change in Response with Temperature.



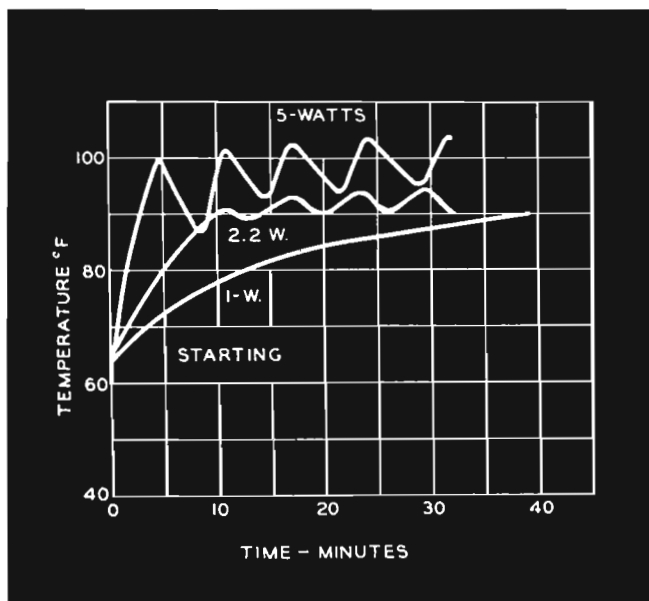

FIG. 4a. (Above) Warm-Up Time and Temperature Fluctuations at Damper Block for Different Heater Dissipation.

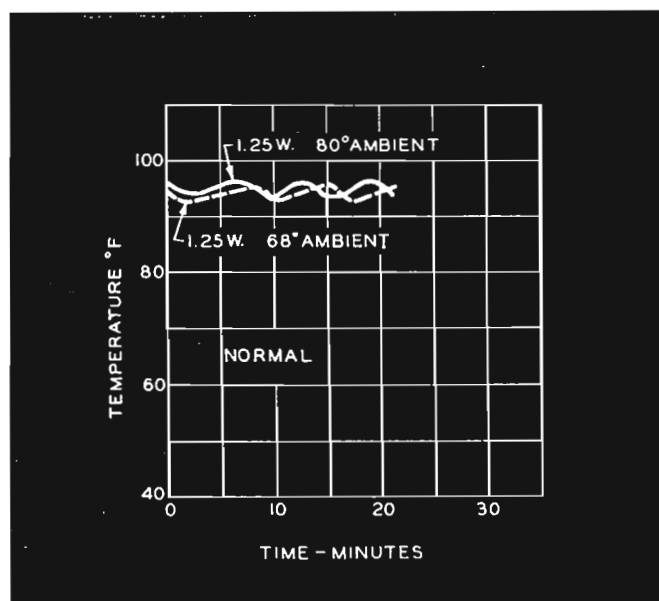
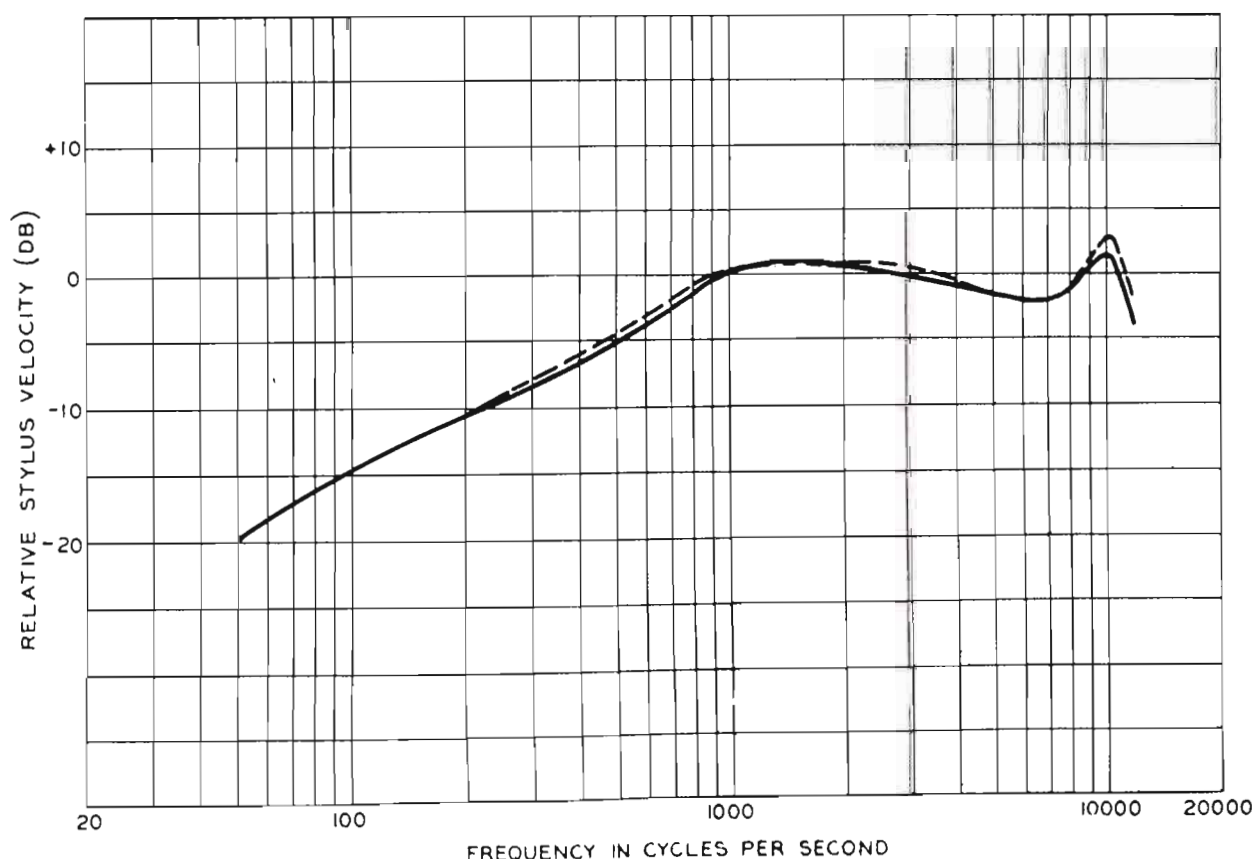

FIG. 4b. Temperature Fluctuations after Suitable Warm-Up Time.

FIG. 5. (Below) Response Measurements Taken Six Months Apart—Note Only a Slight Change in Characteristic, an Improvement Resulting from Controlled Temperature Operation.



block and the thermostat, and locating the thermostat so that its temperature would be nearly that of the viscoloid, a reasonable degree of temperature control could be maintained. Preliminary tests indicated that such an arrangement would be satisfactory, and the development and design work was continued along this line.

### Operating Temperature

Ideally the temperature should be high enough so that it is never exceeded during operation. This may be impractical, however, and a somewhat lower temperature may be found that is just as satisfactory. Tests were made at many different temperatures, and the results of these are shown in Fig. 3. The curve obtained at 80° F. could possibly be made smoother by adjusting the viscoloid damper, but the trend toward smoothness with a higher temperature such as 95° F. is clearly evident. An operating temperature of 110° F. is too high, as sufficient damping at the fundamental resonance (about 1200 cycles) is not readily obtained without a radical change in the damper block design. The dotted curve marked "cutting" was obtained while actually recording a lacquer disk and shows the decrease in level due to loading of the stylus tip. The other curves were taken with the stylus vibrating in air or unloaded, in order not to confuse loading changes with those caused by temperature. The improvement in sensitivity at the low frequencies with a higher temperature is well illustrated by the curves. A temperature of 95° F. was finally selected as the normal operating value.

### Power Requirements

The ideal case would be to apply a minimum of power and so have the current flowing a major portion of the heating cycle. Too great a power dissipation causes wide fluctuation in temperature as is illustrated in Fig. 4a, where tests were made using three different powers, with the thermostat set to open at 95° and close at about 93° F. Overshooting occurred and a maximum temperature of 104° was observed when five watts was being dissipated; with 2.2 watts the fluctuation was less; and with one watt the fluctuation was small, but the warm-up period was found to be long. These tests were made at an ambient temperature of 65°; at an ambient temperature of 80° and a power dissipation of 1.25 watts, the fluctuation was found to be reasonable, and this power was selected for normal operation.

### Quick Heating Control

The warm-up period required by the 1.25 watts is long and to reduce it, and also provide sufficient heating for operation below an ambient temperature of 65°, an externally mounted resistor of seven ohms is used in series with the heater (14.5 ohms). This resistor is shunted by a switch which, when closed, applies 2.75 watts to the heater. From the curves of Fig. 4b, it can be seen that a warm-up period of about ten minutes with this amount of dissipation is necessary. Once the operating temperature is reached, the shorting switch should be opened so that normal power will be applied, resulting in minimum of temperature fluctuation.

### Low Temperatures

The normal power of 1.25 watts is sufficient to maintain the operating temperature of 95° with an ambient temperature as low as 65° F. Below 65°, automatic operation may be obtained by connecting a thermostat across the external resistor to short it out for temperatures below 65° and so apply full power (2.75 watts) to the heater. With this increase in heater power, good temperature control is maintained as low as 45°. The hardness of the lacquer increases greatly as the temperature is decreased, making it difficult to cut a smooth, quiet groove. It is therefore questionable whether recording at low tem-

peratures would be satisfactory unless the recording blanks were also warmed.

### Additional Benefits

Some of the additional benefits derived from operating the viscoloid at 95° have been mentioned. Stability and smoothness of response is one. Calibration checks over long periods of time show very little change response, as illustrated by Fig. 5, in which measurements were made at a six-months' interval. An increase in sensitivity throughout the low-frequency end, where the peak energy of program material is the greatest, is another. Increased sensitivity requires less current and hence less flux for a given amplitude of cut, and usually results in less distortion in the magnetic circuit.

Continuous application of sine-wave signal causes some additional heating not experienced with program material containing speech and music. The increase in level found when applying a 1000-cycle signal is shown in Fig. 6a. At other frequencies, continued application of an oscillator signal produced practically no change in recording level. However, if a high-frequency signal was applied for an appreciable time and the response at 1000-cycles checked, a greater change in recording level was noted than when only the 1000-cycle signal had been used. This is believed to be due to magnetic losses, causing the armature to become hot and in turn heat the viscoloid attached at the end of the armature shaft and so change the damping characteristic. Considerable improvement in this respect has been measured with the MI-11850-C, as can be noted in Fig. 6b, where a comparison with an MI-4887 is made.

This change in recording level should not present any difficulties in program recording, for which the cutter is primarily designed. However, when calibrating or making frequency runs, long applications of high-frequency sine-wave signals should be avoided.

The increase in sensitivity also results in a shift of the crossover point (constant velocity to constant amplitude of stylus motion) to the lower frequencies. This is desirable, as less electrical compensation is then required in order to meet the NAB standard lateral recording characteristic with its theoretical crossover at 500-cycles.

A typical response characteristic while cutting at an average diameter at 33 $\frac{1}{3}$  r.p.m. is shown in Fig. 7.

### Mechanical Improvements

The appearance of the MI-11850-C is different from that of its predecessor, the MI-4887, due to a re-arrangement of the mechanical parts, mainly the permanent magnet that supplies the d-c flux. This was done to minimize the mechanical bounce<sup>4</sup> often encountered during recording where the cutter oscillates vertically, cutting grooves of varying depth. By decreasing the inertia and properly locating the pivot points, this form of instability has been reduced to a minimum and anti-resonators or dash pots are no longer required. An advance ball holder with an adjusting screw which projects through the case has been designed for those who wish to use this method of groove depth control.

### References

<sup>1</sup> H. E. Roys: "Experience with an FM Calibrator for Disk Recording Heads," *J. Soc. Mot. Pict. Engrs.*, Vol. 44, No. 6 (June 1945), pp. 461-471. Also BROADCAST NEWS, Vol. 43 (June 1946), pp. 42-47.

<sup>2</sup> J. P. Maxfield and H. C. Harrison: "Methods of High Quality Recording and Reproducing of Music and Speech Based on Telephone Research," *Proc. A.I.E.E.*, Vol. XLV (Feb. 1926), p. 334.

<sup>3</sup> H. J. Hasbrouck: "Lateral Disk Recording for Immediate Playback with Extended Frequency and Volume Range," *J. Soc. Mot. Pict. Engrs.*, Vol. 32 (Mar. 1939), pp. 246-251.

<sup>4</sup> H. E. Roys: "Force at the Stylus Tip While Cutting Lacquer Disk Recording Blanks," *Proc. I.R.E.*, Vol. 35, No. 11 (Nov. 1947), pp. 1360-63.

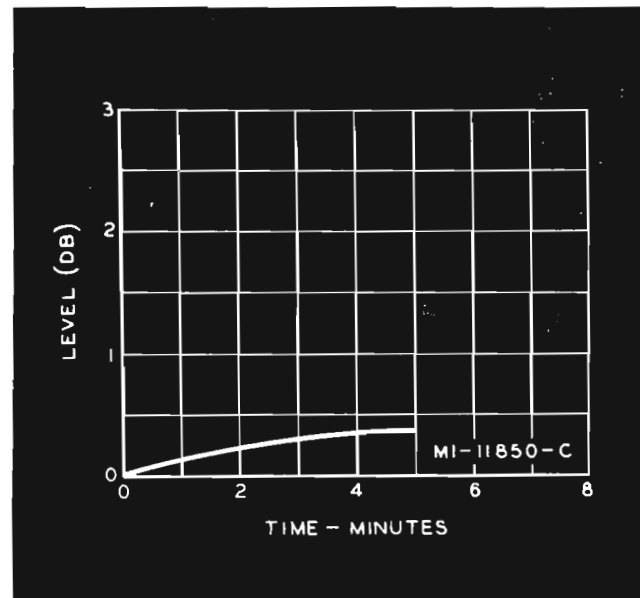

FIG. 6a. (Above) Continuous Application of Sine-Wave Signal Causes Some Increase in Recording Level at 1000-Cycles.

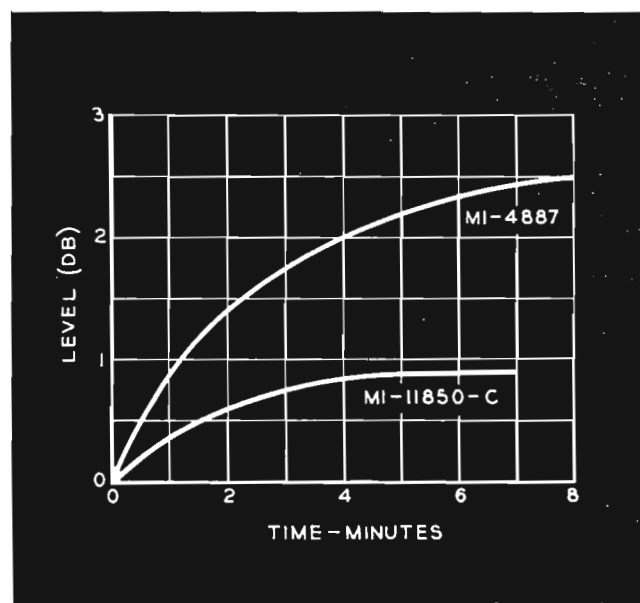

FIG. 6b. Continuous Application of 5000-Cycle Signal Causes a Greater Change in Level at 1000-Cycles. Note, However, the Improvement Obtained with the MI-11850-C over the MI-4887, which was not temperature controlled.

FIG. 7. (Below) Typical Response Characteristic While Cutting at an Average Diameter at 33 $\frac{1}{3}$  r.p.m.

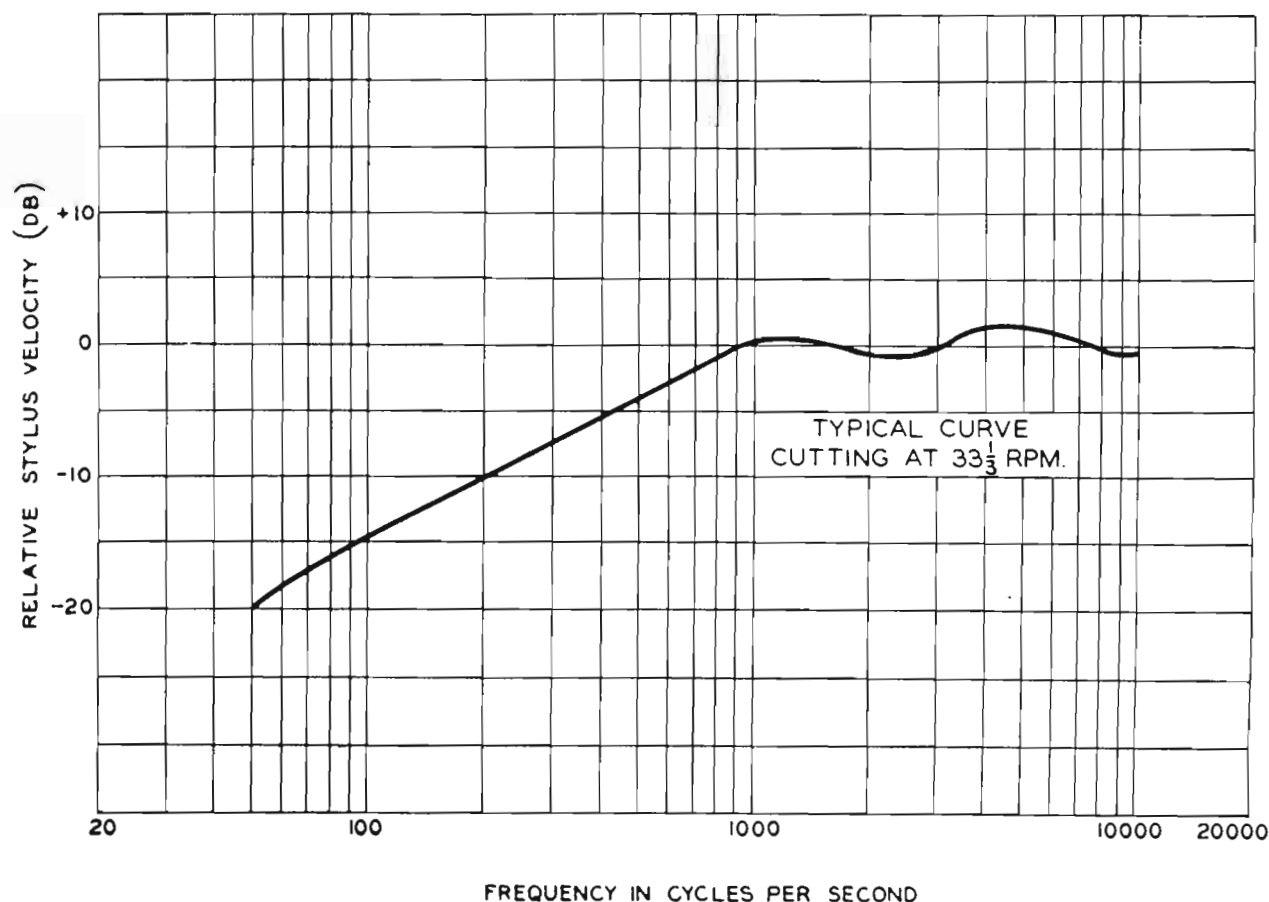



FIG. 1. Goar Mestre is the General Director of the CMQ Network and its originating station CMQ. He is currently president of the Inter-American Association of Broadcasters.

# CMQ

## Havana's Key Station Is Radio Showplace Of Cuba

Radiocentro, the Radio City of Cuba, boasts the most modern and best equipped radio facilities in the Caribbean Area. Completed in the Spring of last year, after very extensive planning, the broadcast station includes eleven studios and is equipped to handle as many as four programs simultaneously, from the simple disc jockey show to a full 150 piece symphony concert.

The studios, while only a part of Radiocentro, which incorporates a theatre, offices, retail stores, a bank, restaurants and many other business outlets, are those of

Havana's Radio Station CMQ, key station of the CMQ Network which covers the greater part of Cuba.

The CMQ studios are shared jointly by Station CMBF, and Radio Reloj, with facilities available for a fourth emergency standby station which can be used by either of the other three.

Two of the eleven studios, beautifully decorated and draped, are built with large theatre-type stages and can accommodate audiences of more than 350. Another studio

is designed to give best musical efforts to a symphony orchestra, while still another is best for plays, quiz programs and other speech type shows. There are separate studios designed for cutting transcriptions and still other facilities for newscasting and rehearsing.

Every one of the studios located in the sound-proofed Radiocentro building is individually air-conditioned and acoustically treated with polycylindrical diffusers in artistic and effective arrangements as shown on page 57.

FIG. 2. Gathered around the master control console are the men who made possible Cuba's \$3,000,000 Radiocentro. They are, left to right: Miguel Humara, of the firm of Humara and Lastra, RCA distributors in Cuba; Dudley Wood, Regional Director of the RCA International Division for Latin America; Goar Mestre; Meade Brunet, Vice-President of RCA, and Managing Director of the RCA International Division; Julian Lastra, of Humara and Lastra; and M. S. Hazzard, RCA Field Representative in Cuba.





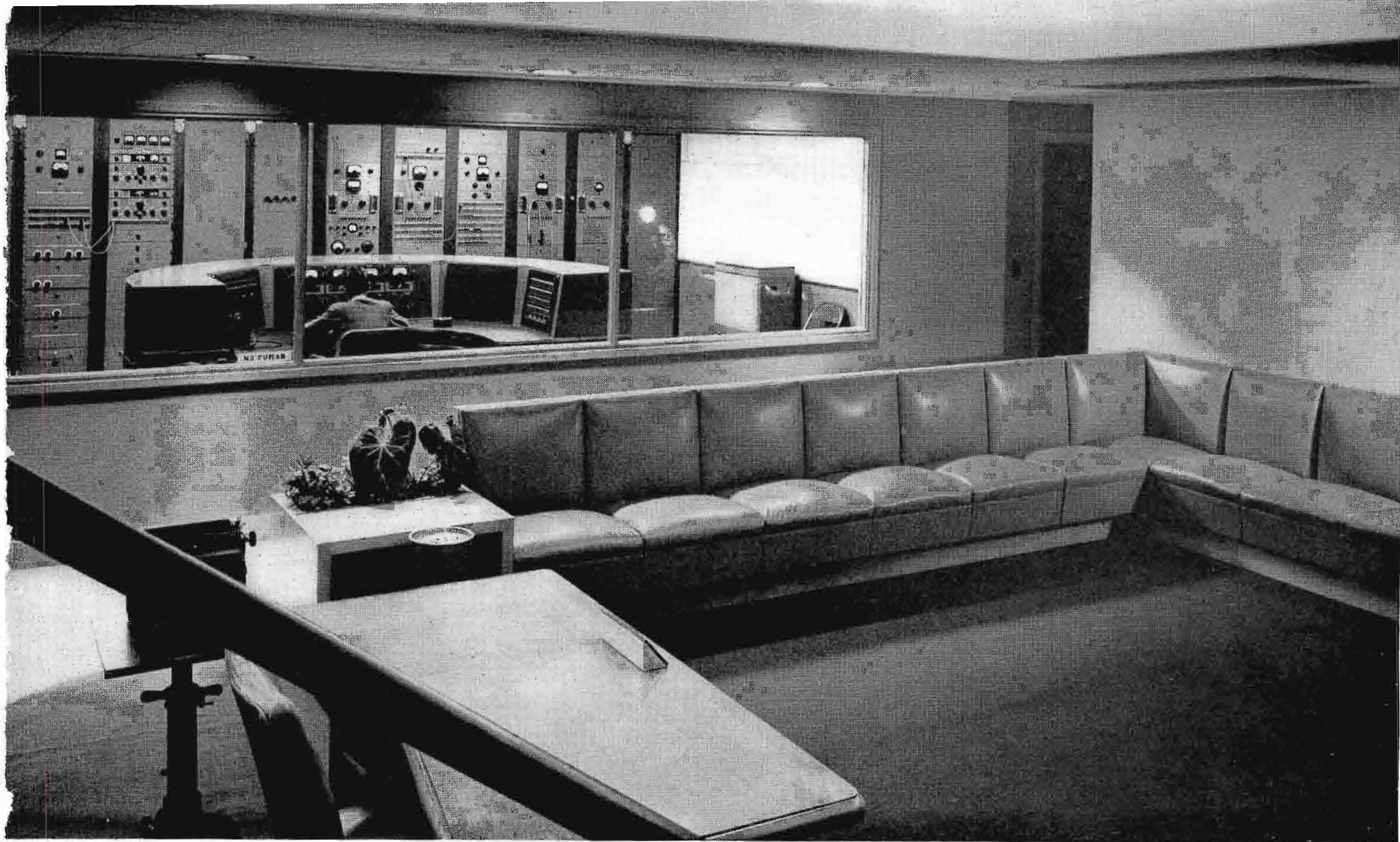

FIG. 3. This is just one of CMQ's modern waiting rooms. Adjacent to it is the master control room which is seen through the sound-proof glass partition. An operator is seated at the semi-circular master control console which monitors the network and local programs. Behind the console are located the numerous audio and test and measuring equipment racks.

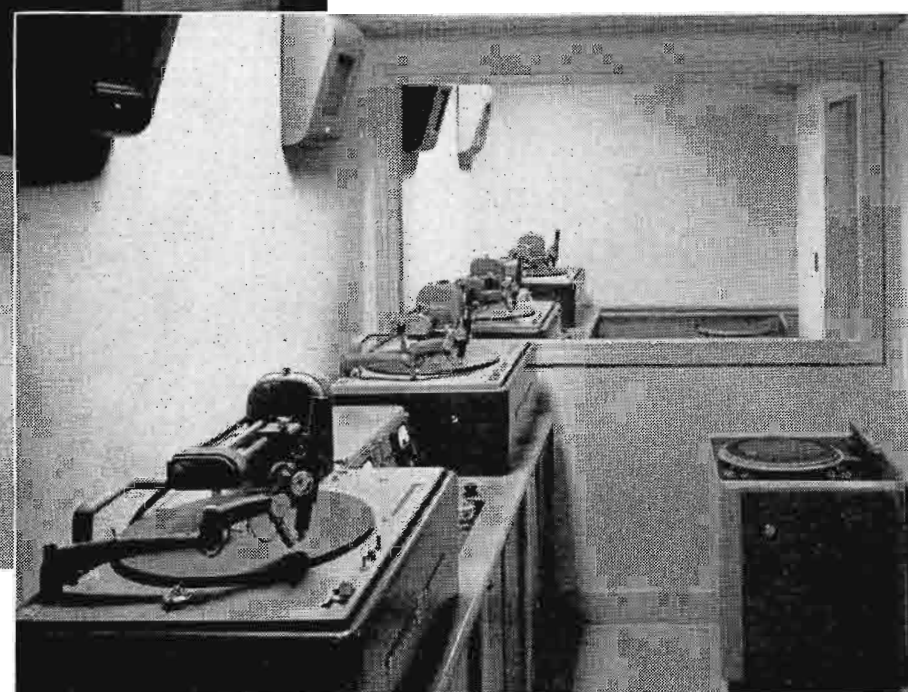
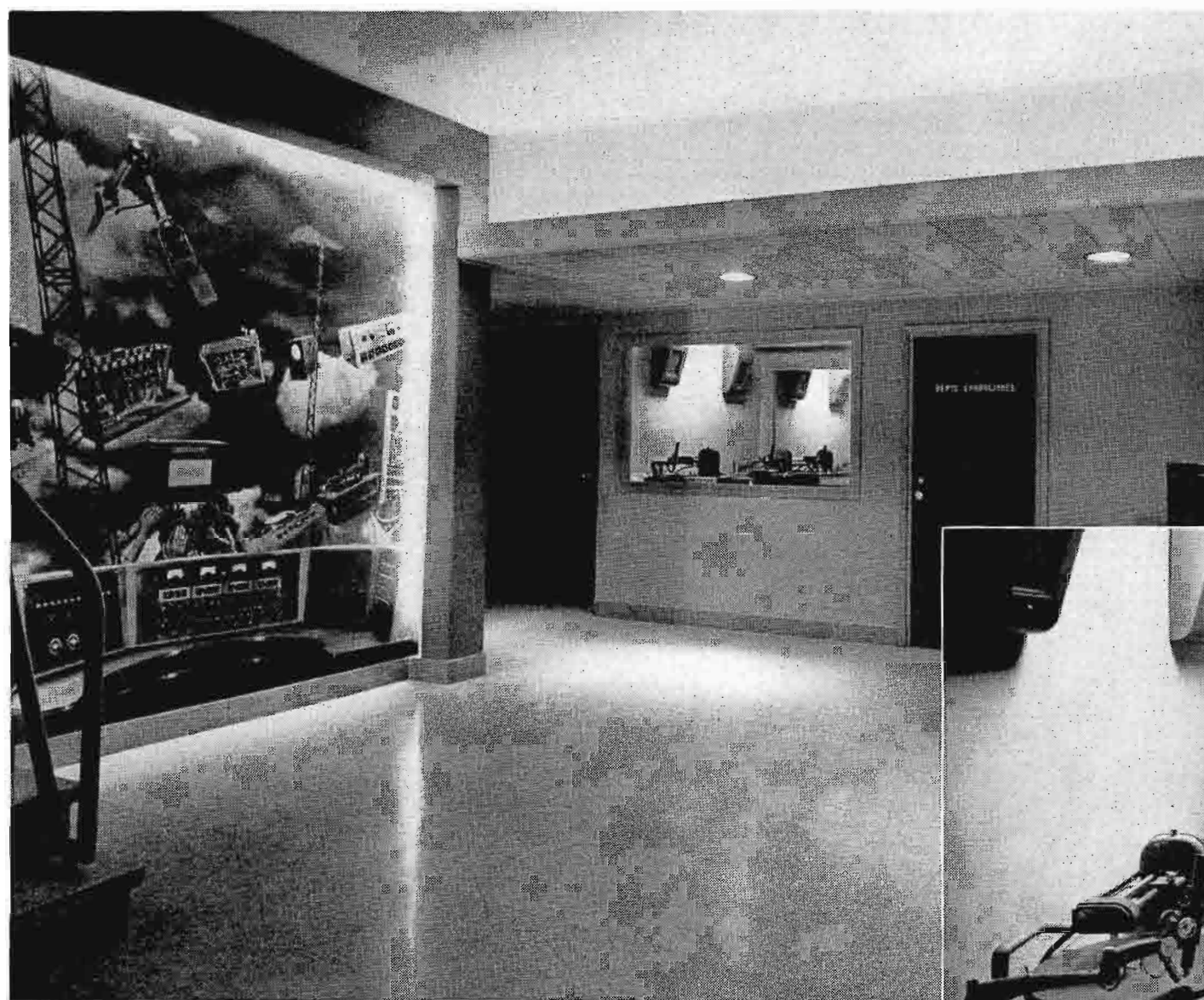
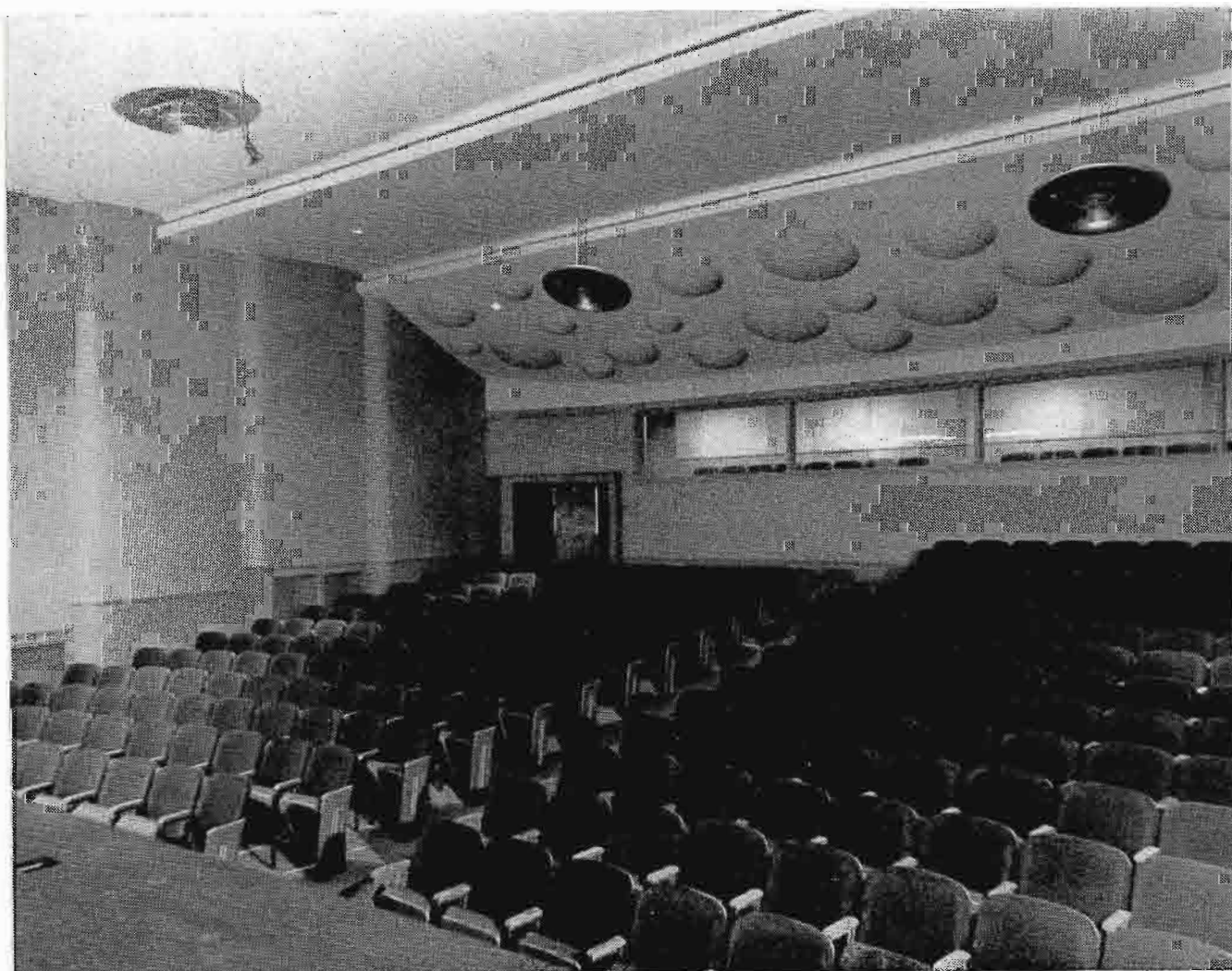

FIG. 4. An interesting mural consisting of a montage of radio equipment decorates the corridor leading to the recording rooms. The inset shows four RCA 73-B Professional Recorders and 70-D Transcription Turntables which are used by CMQ in its deluxe installation.



▲  
 FIG. 5. This is one of CMQ's huge theatre-type studios which seats 350 people. Its large stage can accommodate a full 150-piece symphony orchestra. On either end of the stage can be seen an RCA LC-1A Loudspeaker which is part of the sound reinforcement system for the studio. On the left side of the stage is the engineer's control booth and immediately above it is the sponsor's booth.



◀ FIG. 6. This is another view of the studio shown above, but taken from the stage facing the rear of the studio.

FIG. 7. The photographs at the right illustrate some of the very interesting and artistic acoustical treatment of the three "live" studios. The studio shown at top is used for large orchestras. The other two are used for dramatic programs and small radio shows.

Each studio has its individual control room with connecting lines to the master control console which was designed for CMQ by the RCA International Division. The master control unit has complete facilities for program monitoring and switching and is equipped to handle fifty remote lines. The custom unit, constructed semi-circular for convenience of operation and including racks of audio amplifiers, switches, relays, meters, is connected by approximately a half million feet of wire to the various studios and transmitting equipment. From the master monitor position, it is very easy to switch any of the programs to the recording rooms which are equipped with four RCA Type 73-B professional recorders and custom-built recorder control consoles. If a program calls for special effects, any of the studios can be switched to the very elaborate sound effects studio and echo chambers.

Even the studio seats have been scientifically designed for best acoustics. Because of this special treatment, the studio seats offer the same coefficient of sound absorption when they are empty as when they are occupied. In other words, each seat when empty reacts to sound vibrations exactly the same as when filled. Because of this, according to the station engineers, it is always possible to obtain uniform tonal quality and determine the level of a program during rehearsal, even before the studio is full. The two theatre-type studios are equipped with RCA custom-built sound reinforcement equipment to permit the audience in every part of the studio to adequately hear the performance.

Designed with an eye to the future, Radiocentro has made provisions for expansion to FM and television when these services become practicable in Cuba. Then it is hoped by CMQ that Radiocentro will become the television and broadcast center of the island.

The technical layout of CMQ was engineered by the RCA International Division in conjunction with Humara y Lastra, RCA Victor Distributors in Cuba, and Ventura Montes, director of engineering for the station and the CMQ Network.

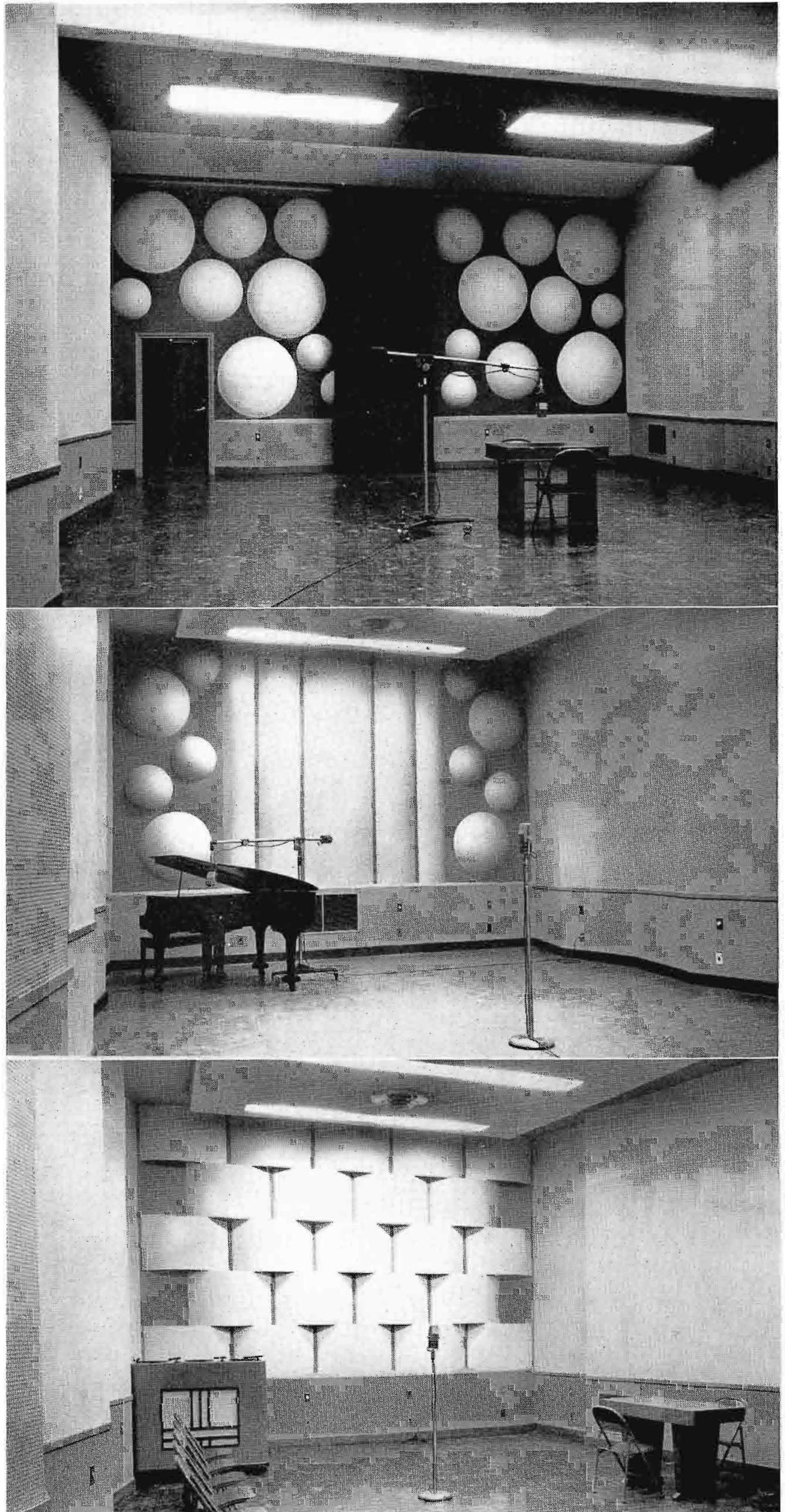



# STUDIO PICKUP TECHNIQUE

by H. M. GURIN

Engineering Dept., National Broadcasting Co.

Progress in the engineering development of broadcasting equipment and studios has been greatly accelerated in the last decade, and noteworthy contributions have been made in this field.<sup>1</sup> As a result, the expectations of higher standards of technical perfection and performance may be justified. The usefulness of any improvement is premised on the skill with which this information can be applied so that the quality of the performance can keep pace with technical advances placed at one's command.

In broadcasting, whether it is AM or FM, the primary purpose is to bring to the listener, in the most pleasing and intelligible manner, whatever information may be transmitted. For speech, one would normally look for intelligibility and naturalness of the reproduced sound so that a mental picture of the person and his surroundings may be formed as well as the message being clearly understood. In music,

faithful reproduction without distortion and the enhancement of musical programs to heighten the listeners' personal pleasure are the major objectives.

The transmission of sound from a broadcasting studio, to achieve the results mentioned above, involves a number of technical factors among which are:

- a. The acoustics of the studio.
- b. The electrical system characteristics, (amplifiers, filters, microphones, etc.).
- c. The studio pickup and microphone technique.

It is with the last mentioned item that this article is primarily concerned, and only some comments will be made of the first two factors. Since the program is to originate in a broadcasting studio of conventional design, it is assumed that: (1) the frequency/reverberation time characteristic of the space is acceptable, (2) that the volume is adequate for the intended

programs and audiences, if any, (3) that the diffusion of the sound field obtained by proper acoustic treatment and geometrical configuration is satisfactory and that no unusual grouping of resonant frequencies exists.<sup>2</sup> It is further assumed that in the electrical system<sup>3</sup> (1) there is no discrimination in any of the component parts against any frequency within the range under consideration unless specifically desired for special effects, (2) there is a minimum of phase distortion, (3) there is a minimum of harmonic distortion, (4) there is a minimum of extraneous noise.

<sup>1</sup> Nygren, A.—*FM and Television*, May 1946, Vol. 6, No. 5, p. 25; Volkmann, J. E.—*Journal of Acoustical Society of America* XIII 234 (1942); Olson, H. F.—*RCA Review*, Vol. 1, No. 4, p. 68 (1937); Olson & Massa, "Applied Acoustics," P. Blakiston Sons, Philadelphia.

<sup>2</sup> Morse, P. M. & Bott, R. H.—*Rev. Mod. Phys.* XVI, 69, 1944.

<sup>3</sup> NBC Engineering Department Bulletin—"Down to Earth on High Fidelity"—O. B. Hanson, C. A. Rackey, G. M. Nixon.

## Studio Pickup Technique

Of the factors listed, probably the most controversial is that relating to studio pickup technique, which includes the applications and placement of microphones and performers. It is important to remember that the system we are dealing with is monaural and lacks the ability to discriminate as to the location of a sound, although it can differentiate as to apparent distance of the source of sound to the microphone.

When sound is generated in a space, the collecting system, via the microphones, is generally so oriented that the first sounds come from the source directly and are followed by the sound reflected from the surrounding surfaces. When the absorption between boundaries equals the output of the source, the steady state condition is reached. The ratio of reflected to direct sound is considered the effective reverberation of the collected sound. It is obvious that an increase in the total number of reflections reduces the energy density of each reflection and permits a more uniform and diffusive sound field to exist.

The proportion of reflected to direct sound in a pickup is determined only partly by the acoustical characteristics of the studio. The directional character of the sound source and the receptive angle of the microphone used as well as its distance from the source are also important.

Fig. 1 illustrates the relationship of reflected to direct sound energy,  $E_r/E_d$ , with respect to distance of the sound source from a ribbon velocity microphone in a suitably treated studio for frequencies between 200 and 1000 cycles. It is readily apparent that any enhancement of the tonal quality of a singer or instrumentalist by the acoustical properties of the studio is negligible when the performer is too close to the microphone. Fig. 2 shows the energy response for various microphones in a typical studio.

Since most musical sounds and human voices produce sound waves of a complicated series of harmonics, each with a different wavelength, frequency and amplitude, two or more microphones placed at unequal distances from the source of the waves will receive them successively, rather than simultaneously. The time interval will cause the composite wave to present a different arrangement of its harmonics to each microphone at a given instant. If the outputs of these microphones are then blended and reproduced by a single loudspeaker,

**TABLE I**  
**General Properties and Characteristics of Microphones**

Model	Type	Frequency Response**	Output Impedance	Output Level*	Directional Characteristics
RCA 44-BX	Ribbon Velocity	30-15,000 ±6 db	50/250	-55 vu	Bi-directional
RCA 77-D	Combination Ribbon Velocity and Pressure	30-15,000 ±5 db	50/250/600	-54.3 vu -57.3 vu -60.3 vu	Bi-directional Uni-directional Non-directional
RCA 88-A	Pressure (moving coil)	60-10,000 ±5 db	50/250	-55 vu	Non-directional
WE 633-A	Pressure (moving coil)	50-9,000 ±3 db	20	-59 vu	Non-directional
WE 639-A	Combination Ribbon Velocity and Pressure	40-10,000 ±4 db	35	-55 vu -61 vu -61 vu	Uni-directional Bi-directional Non-directional
WE	Condenser (with assoc. amplifier)	50-15,000 ±6 db	(Amp. Out.) 30-50/200 250	(Amp. Out.) -45 vu	Uni-directional Bi-directional Non-directional

\* Input level of 10 dynes/cm<sup>2</sup>.  
\*\* Manufacturer's specifications.

**TABLE I (above).** General properties and characteristics of microphones.

**FIG. 1 (below).** Ratio of reflected to direct sound energy with respect to distance from a ribbon velocity microphone.

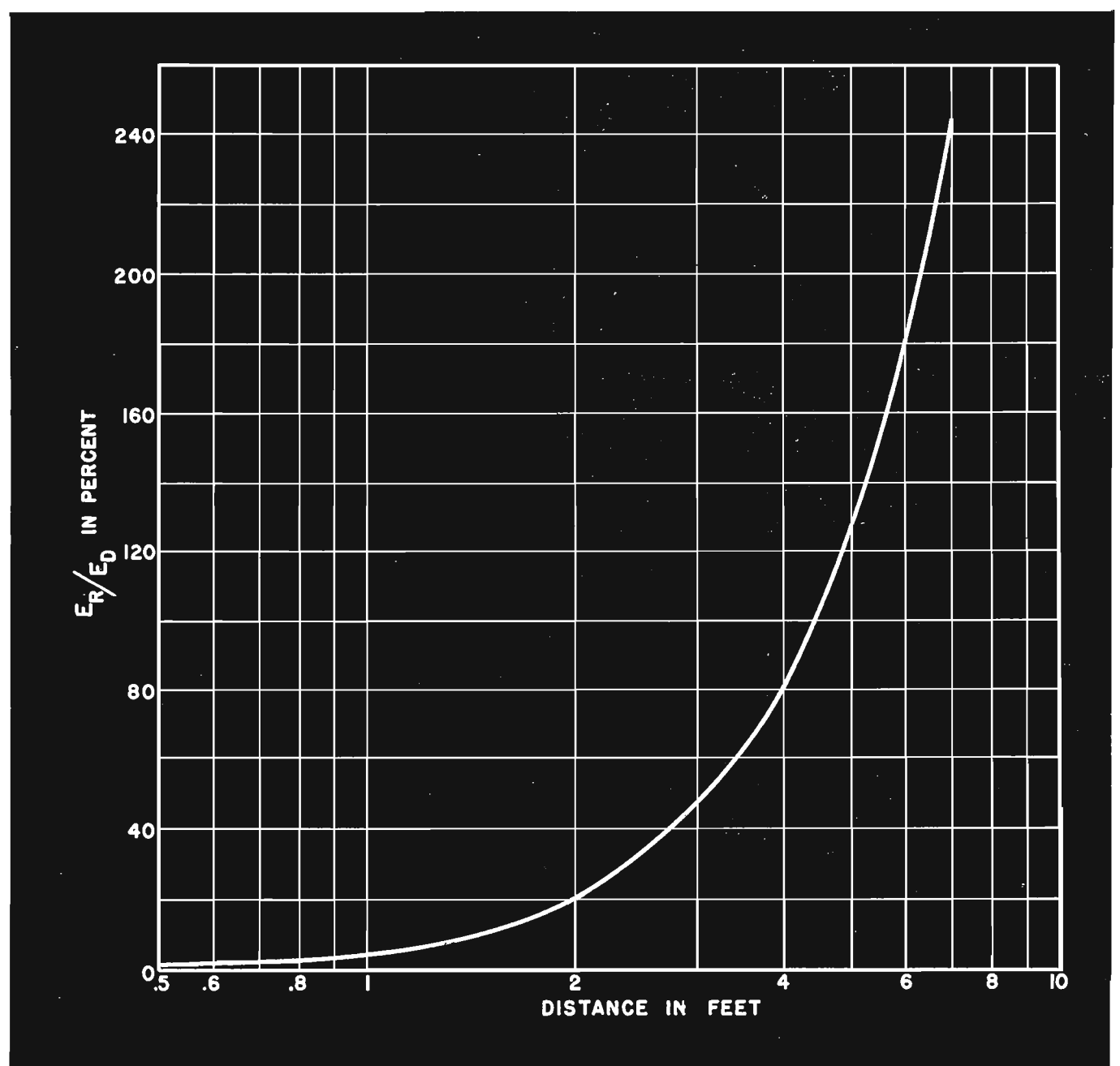

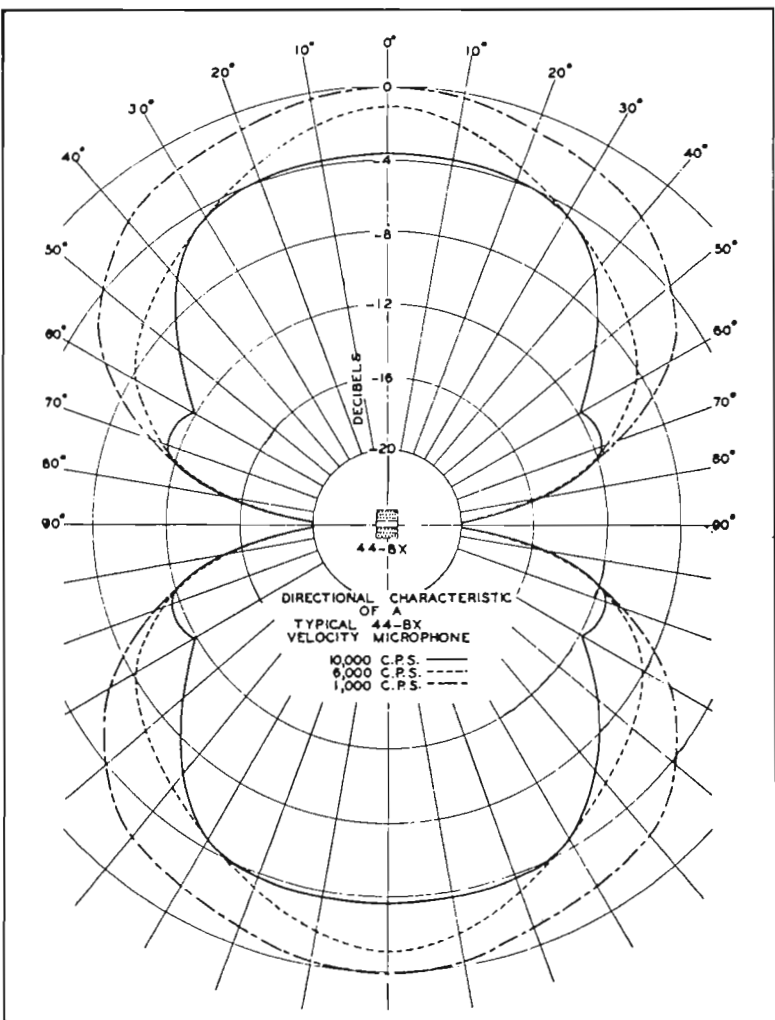
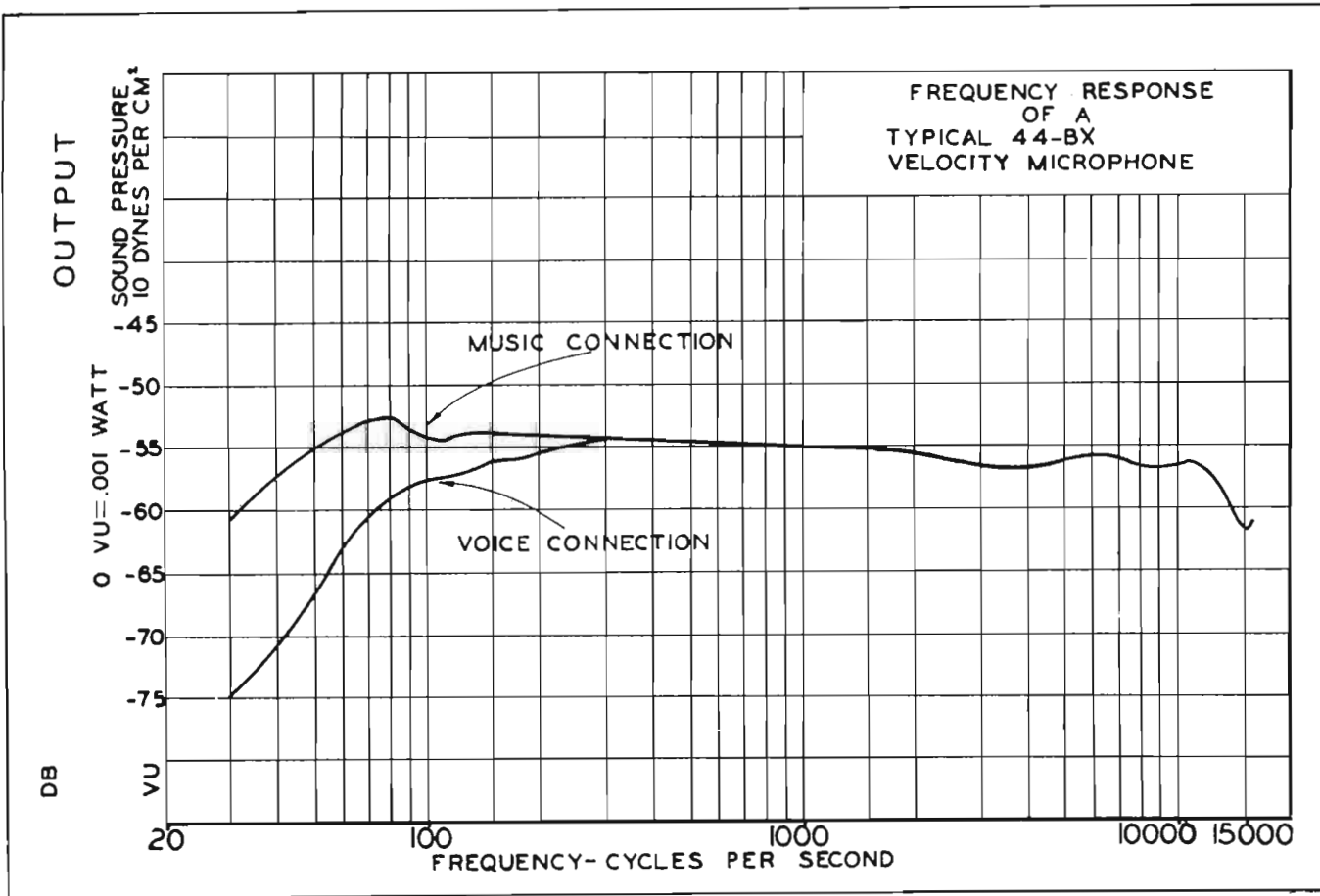
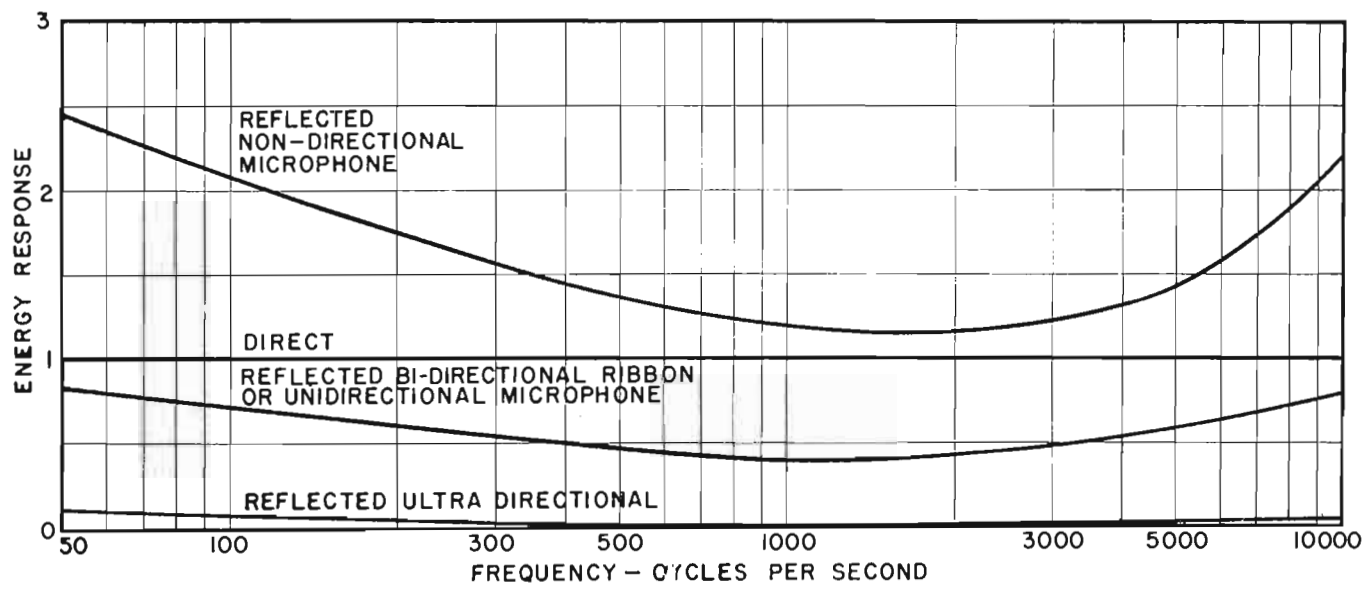

FIG. 2 (top). Energy response curves for direct and reflected sounds in a typical studio.

FIG. 3 (middle). Frequency response of the RCA Type 44-BX microphone.

FIG. 4 (left). Directional characteristics of the RCA Type 44-BX microphone.

the results manifest themselves as raspiness and raucous tones, particularly at the higher frequencies. It is for this reason that single mike pickups are recommended, particularly for musical programs. However, if multiple microphones are required to obtain full coverage, considerable care must be exercised to avoid distortion caused by wave interference and phasing.

A general understanding of the characteristics of the microphones commonly used in broadcasting is of material assistance in selecting the proper type for a specific task to obtain optimum results. The tabulation, Table 1, shows the general properties and characteristics of several such microphones.

Figs. 3-4 graphically show the directional and frequency response characteristics of the RCA-44-BX ribbon velocity microphone. Fig. 5 illustrates the RCA-77-D combination velocity and pressure microphone characteristics.

The acceptability of the final outcome depends in a large measure on the subjective reaction of the individual responsible for the performance as well as on the listener, and for this reason no hard and fast rules can be established. Instead, some illustrations will be given in which various acoustical problems have been met and from which general principles may be derived as a guide to acceptable practice.

When an interview for an individual is conducted or a brief address is being delivered from a small speaker's studio, a bi-directional microphone can be used, from both sides if necessary. The receptive sides of the microphone should be located at least 8 feet from the nearest reflecting wall so that no distortion due to wave interference results. Since the major portion of the sound is direct, as it should be, when articulation is important, the reverberation time should be low. This condition may be carried too far, and sometimes sounds artificial and unrealistic. Under practical application, the apparent reverberation may be increased by increasing the microphone distance from the speaker, thereby increasing the ratio of reflected to direct sound at the pickup point. The bi-directional microphone is particularly suitable for a speaker in a "dead" studio, because the microphone responds to sounds originating both in front and behind it, thereby increasing the apparent reverberation. Of course, where the background noise is excessive or the studio reverberation time is high, a uni-directional microphone which discriminates

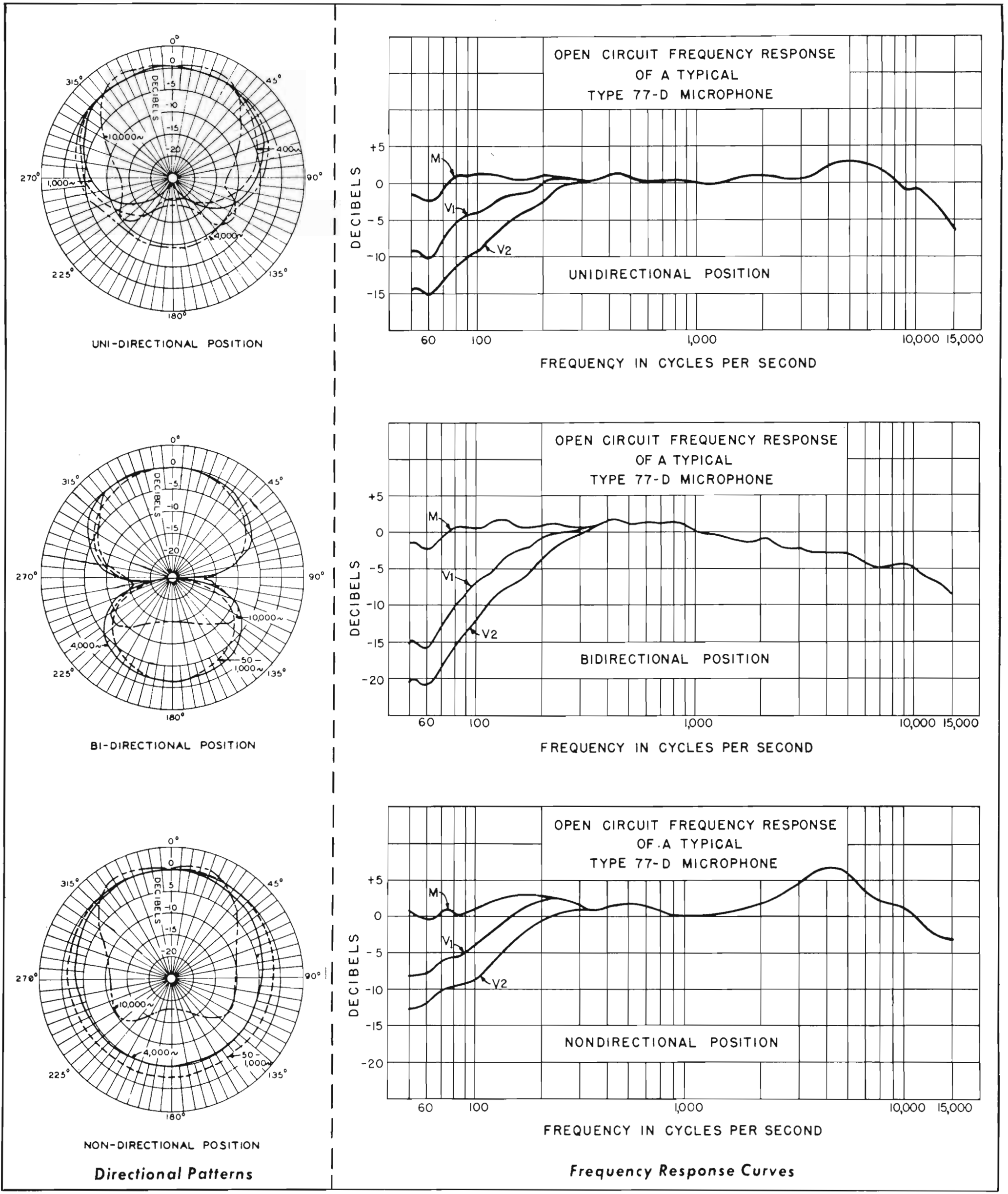

FIG. 5 (above). Directional patterns and frequency response curves for the RCA Type 77-D microphone.

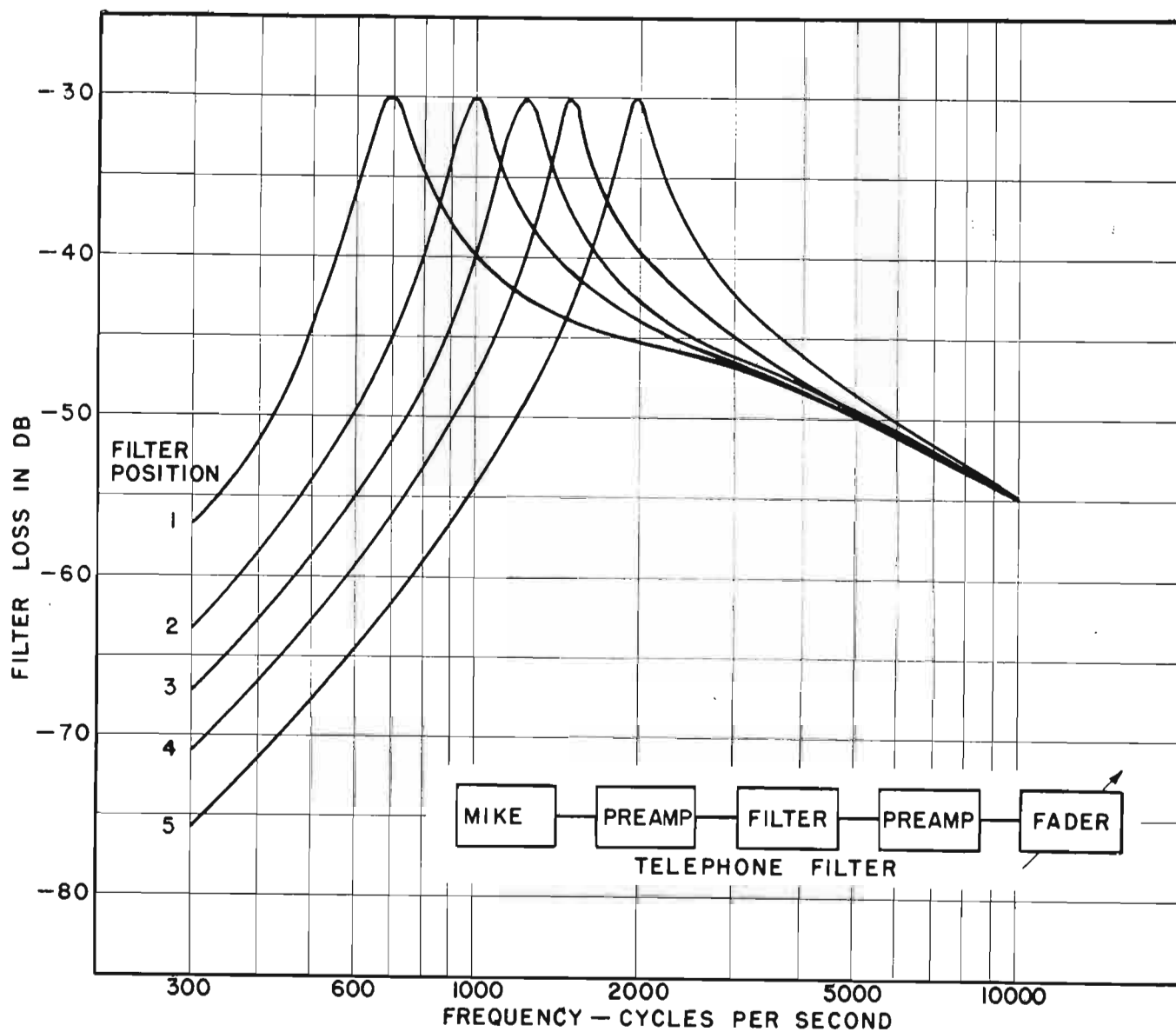

FIG. 6 (above). Typical telephone filter characteristics.

against all frequencies equally, other than those in front of it, is preferable.

### Special Effects

Very often, during dramatic sequences, special speech effects are desired or simulated, as for example, during a telephone conversation or when voices in a cavern or supernatural voices are being reproduced in a fantasy or mystery story. The customary means involve the use of electrical filters and equalizers inserted in the microphone circuit. Fig. 6 is a block diagram of such a device with its corresponding characteristic curves. By means of this unit, a large variety of effects may be obtained as required by the script.

A very useful adjunct along the same line is an echo chamber, within which an additional microphone, either non-directional or bi-directional, and loudspeaker are located and connected in the transmission system so that an artificial delay, together with multiple reflections, are introduced. The echo chamber is sometimes used for musical programs, particularly with small or medium sized groups where an aural effect of spaciousness similar to a concert hall is to be envisioned. Fig. 7 is a block diagram showing an echo chamber line-up. Fig. 8 illustrates a typical arrangement for a dramatic presentation using an orchestra for musical bridges, sound effects, voice effects, together with the usual cast and announcer's microphone.

FIG. 7 (below). Echo chamber line-up.

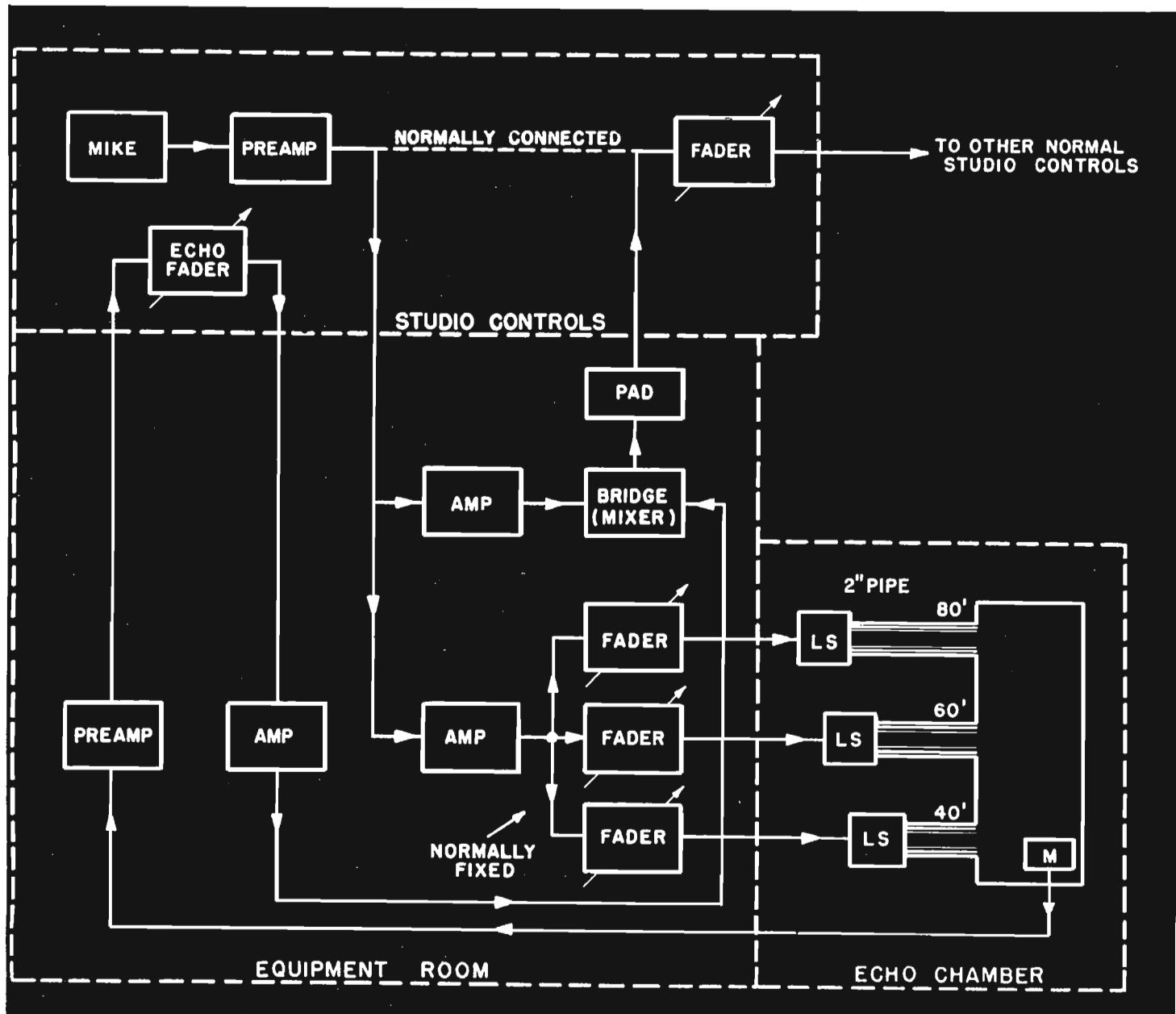

### Groups

In setting up musical groups, the technique for microphone placement in relation to the performers depends on the type of program, the number of participants, and the effect desired. The pickup for a solo instrument or vocalist is generally a simple matter. Care must be taken, however, not to place the microphone close enough to pick up the mechanical noise of an instrument such as a piano hammer, the plucked strings of a guitar, or the surface noise of bowing, as in the case of a violin. In the case of a vocalist, it is important to remember that the low frequency response of the velocity or ribbon microphone is accentuated when the distance between the source and the microphone is less than a wavelength. Consequently, singers should stay at least 3 feet away or more, depending on their volume range. Typical arrangements for voice with piano accompaniment are shown below in Figs. 9A and 9B.

Small musical groups, such as quartets or trios, may be treated similarly to a



soloist with piano accompaniment, with some slight modifications. In this case, it would be preferable to keep all the instruments on the same side of the microphone, as shown in the Fig. 10.

If the microphone is located too close to an instrumental group, high differentiation of the individual instruments would result. If the microphone is further away, the sounds will blend together, as they do when heard in an auditorium or music room, and result in a more realistic and normal reproduction. Care must be exercised, however, in not going too far since "definition" may be lost entirely.

For the concert orchestra, the sensitive and comparatively noise-free ribbon velocity microphone has been highly useful. Because of its uniform receptivity at all frequencies, it permits greater control of the low pitched instruments by proper angular orientation to the axis of a microphone.

It is possible to bring the entire group within an effective angle of 90° by placing a single microphone sufficiently far enough in front of the orchestra. Under such conditions, the arrangement of the instruments needs little, if any, changing from the regular concert seating plan for satisfactory results in broadcasting. Illustrated, in Figs.

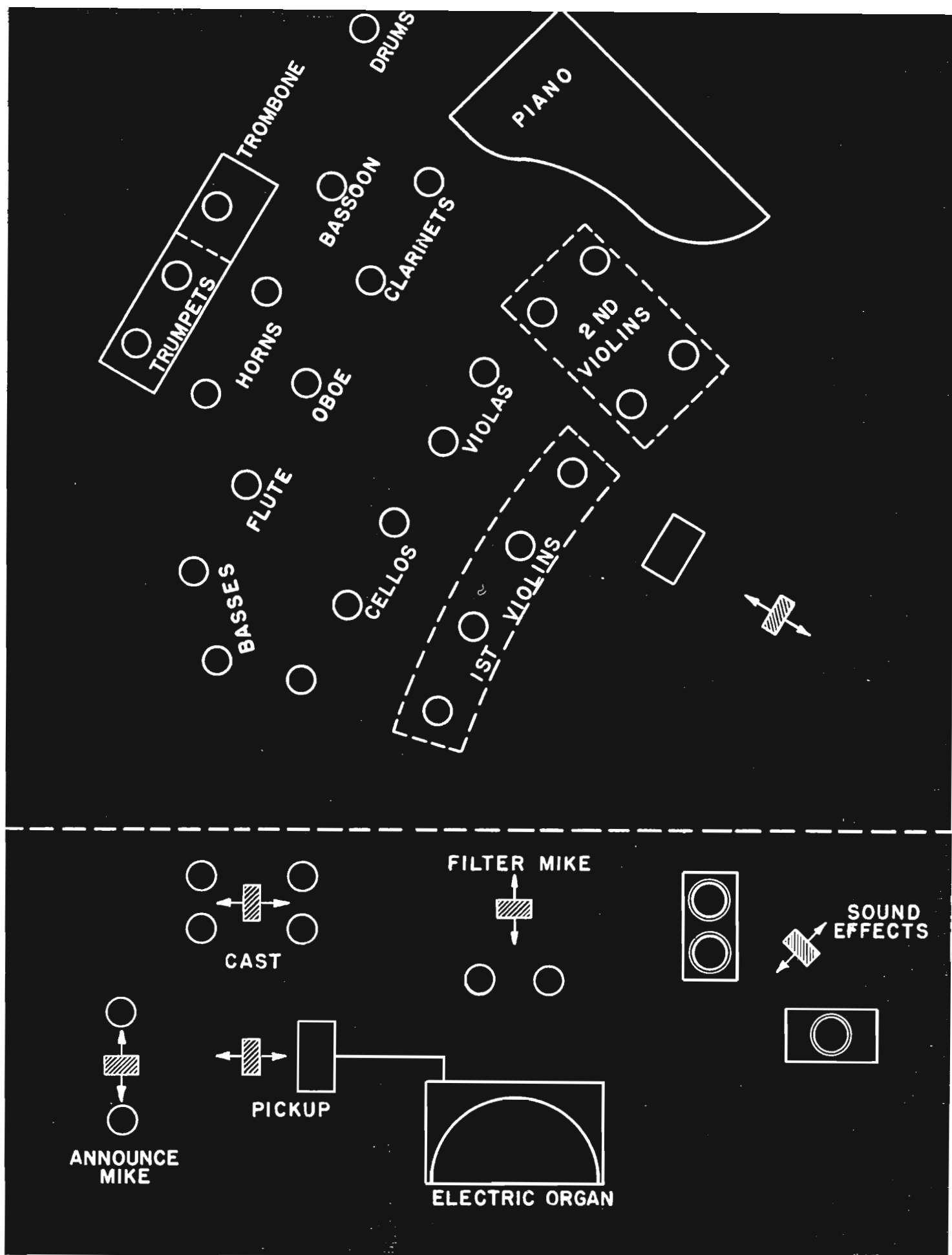
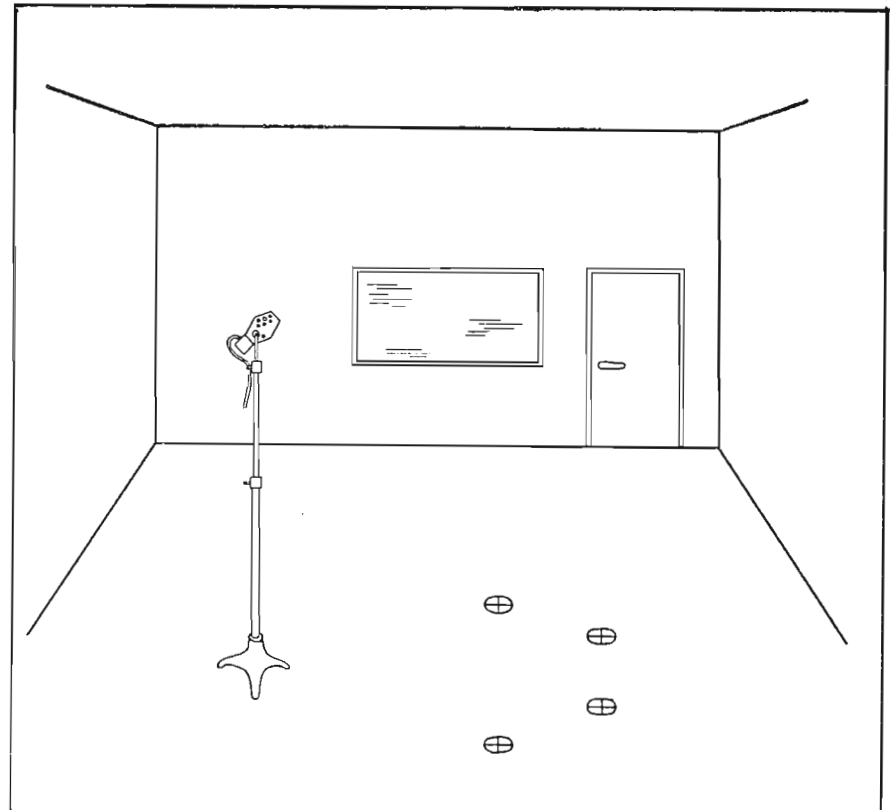
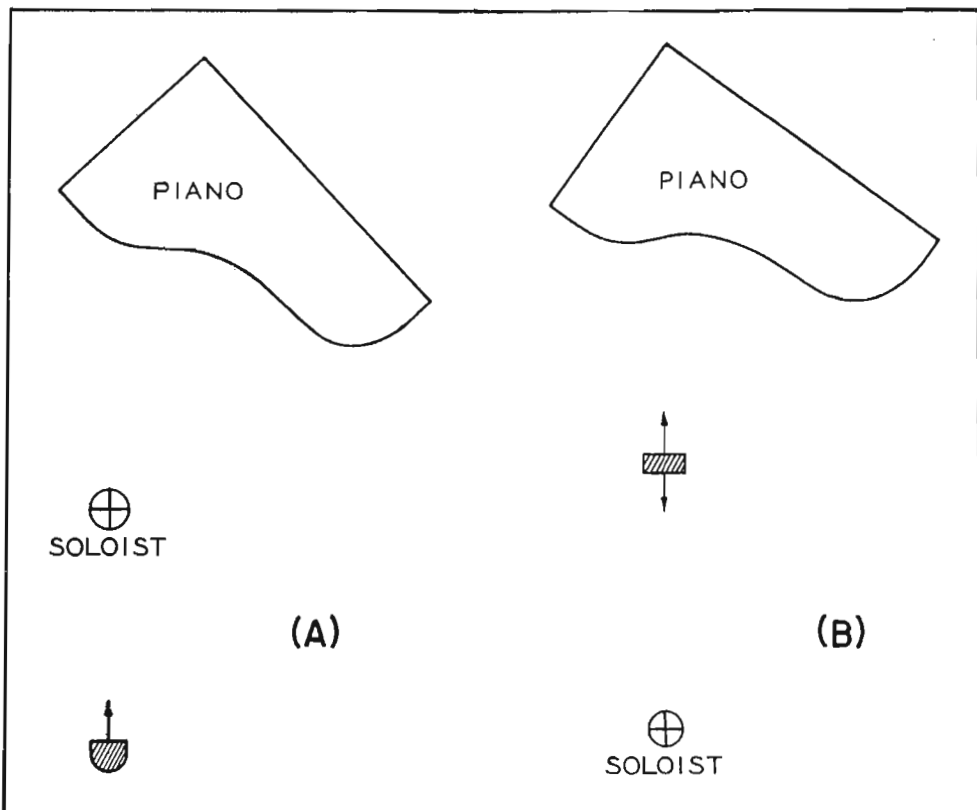

FIG. 8 (right). Setup for dramatic program with musical bridges.

FIG. 9 (left, below). A—Microphone placement for solo with piano accompaniment. B—Alternate microphone placement for solo with piano accompaniment.

FIG. 10 (right, below). Arrangement and microphone placement for small musical groups.



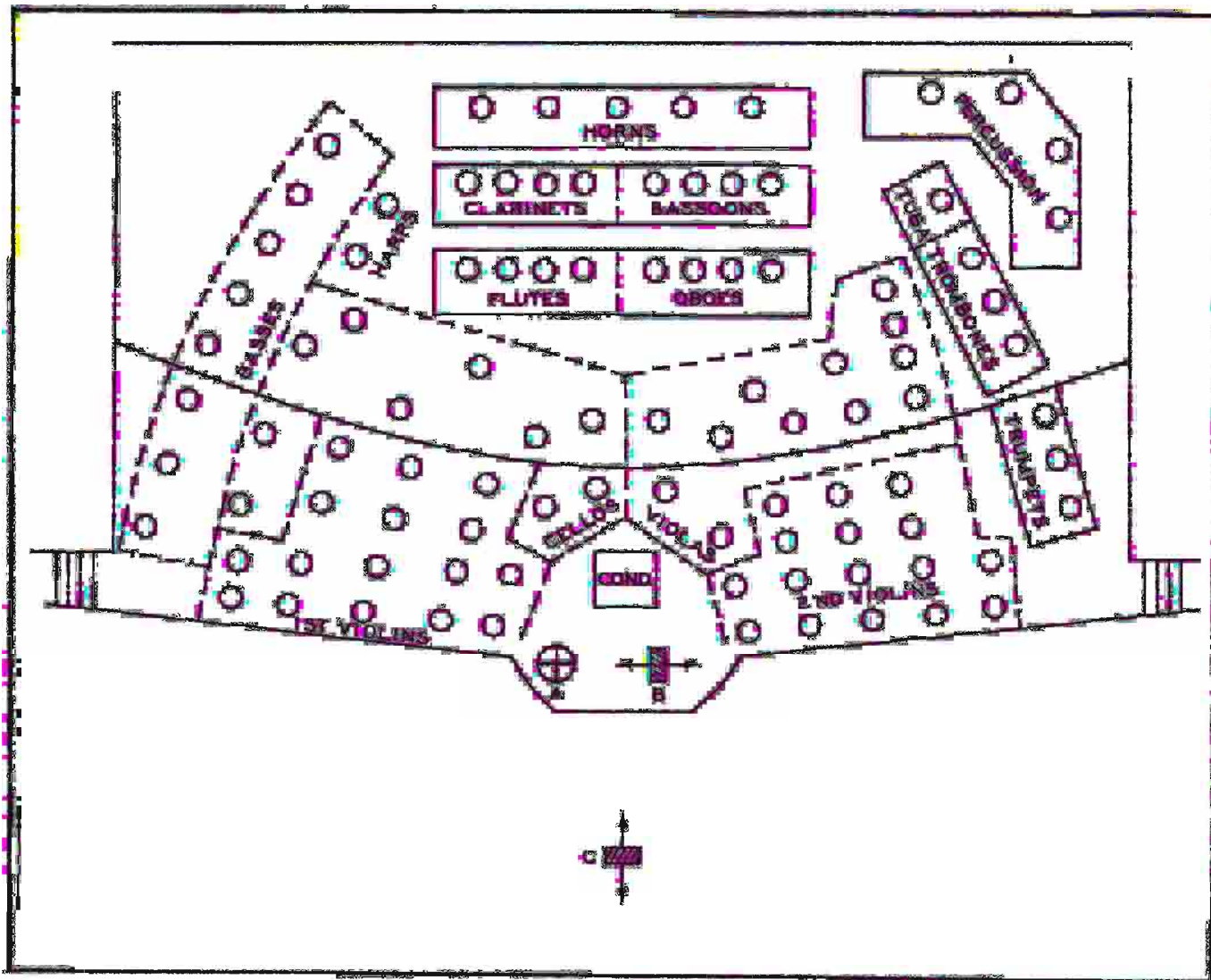

FIG. 11 (above). Arrangement and microphone placement for symphony orchestra and soloist.

11 and 12, are the seating plan and microphone position for the NBC Symphony Orchestra.

The optimum distance and height of the microphone in any pick-up can be determined when all the factors, such as

acoustical conditions, random noise, size and character of performing group, type of microphone selected, etc., are known. Landable efforts<sup>4</sup> have been made in setting up some mathematical basis for determining the position but the elements of personal judgment plus the individual

acoustical character of the space from which the program originates are too important to be neglected.

The varying directional characteristics of the orchestral instruments themselves must be considered; for example, strings, woodwinds and percussion are practically non-directional, while brasses project strongly in the direction of their bells. Since the microphone is essentially non-aerial, it is strongly affected by the directivity of the instruments and since the apparent volume of sound at a given angle is inversely proportional to the distance of the source from the microphone, the strings should be placed nearest and well within the effective response angle of the microphone in use. On the other hand, the percussions are not only non-directional, but capable of almost unlimited volume. Consequently, they should be located at the maximum distance and anywhere within the limits of the response angle. It will be noted that this arrangement is quite similar to the usual concert seating plan.

When a soloist is accompanied by an orchestra, the pick-up for the orchestra remains the same as described above, but the soloist may have a separate microphone, and placed so that its position toward the orchestra is at its minimum response angle as shown in Fig. 11. Frequently, in the case of instrumentalists or vocalists with strong, well-projected voices,

<sup>4</sup>J. P. Maxfield—"Liveness in Broadcasting"—*W. E. Oscillator*, Jan. 1945.

FIG. 12 (below). Microphone elevation and pick-up for orchestra for NBC Symphony.

FIG. 13 (below). Microphone pickup for small concert orchestra.

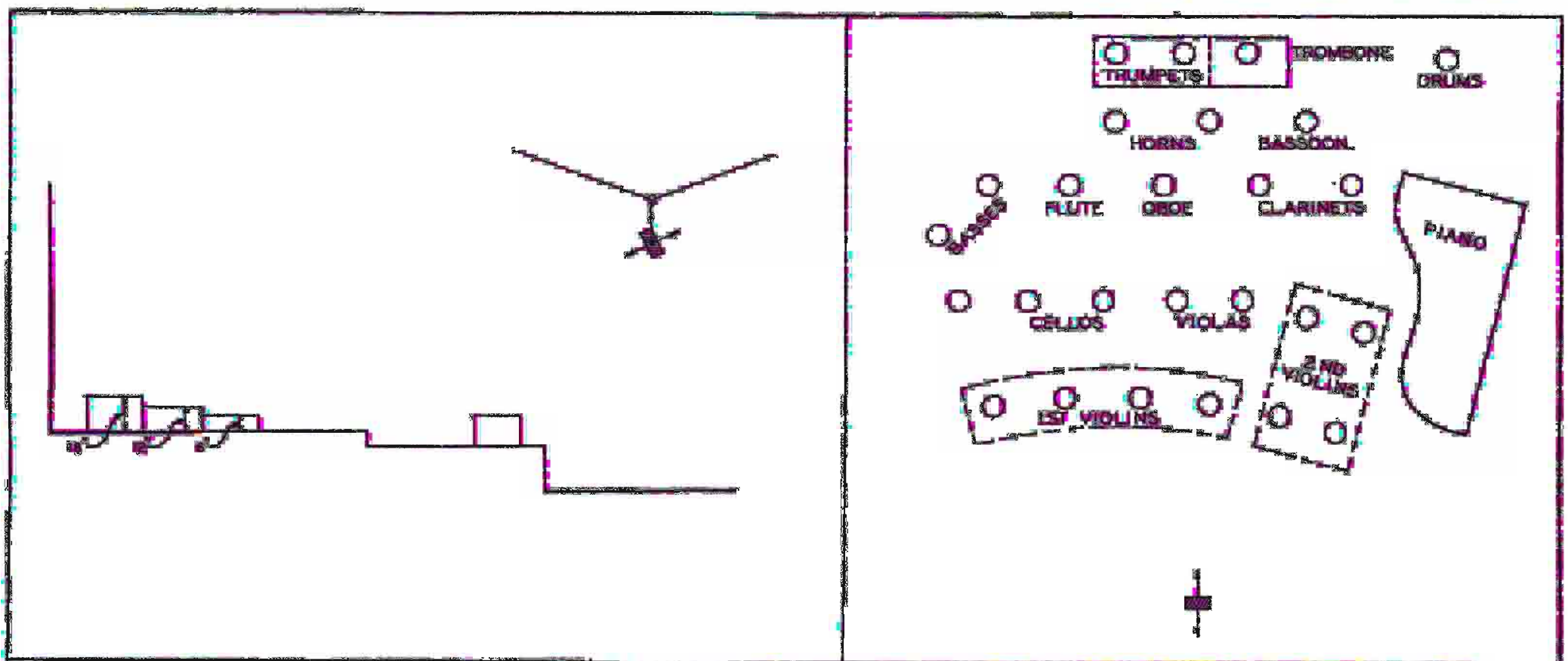

additional microphones are not required, and the orchestra mike serves as the sole pick-up.

### Smaller Groups

For smaller groups, such as a salon orchestra or 20 to 30 piece orchestra, the fundamental treatment is the same as previously described. The principles of directivity and volume of the instruments must be kept in mind, and the weaker, non-directional strings, woodwinds, etc., placed in a correspondingly more favorable location, as illustrated in Fig. 13.

A departure from the single microphone pickup for a musical group is frequently justified when a popular dance band is being broadcast. The use of multiple microphones in many cases is absolutely necessary. When the program originates in night-clubs, hotels, ballrooms, etc., considerable random noise exists. As a result, it is necessary to place the mike as close to the source as possible to exclude the unwanted noise. Because of the proximity of the microphone to the band, all the instruments cannot be included within its effective response angle, and additional microphones are necessary to obtain full coverage.

Another equally important reason for the use of multiple microphones with a dance band is the prominent use of low volume sounds such as a muted trumpet or trombone, and other special effects, which are an inherent part of the musical content itself. Frequently a rhythm section, consisting of piano, drums, bass viol, and guitar are grouped together and separated from the brass and strings. Because of these special effects, a popular singer almost always requires his own microphone. Two illustrations at right, Figs. 14 and 15, show the setup for popular dance bands with and without a vocalist. In most cases, the special effects achieved by use of multiple mikes are considered more important than any detrimental effects due to wave interference.

The foregoing principles as to methods and applications constitute only an outline and indicate the results that might be expected using the various pick-ups, microphones, and acoustical conditions. They are intended as a guide rather than strictly formulated rules. There is no known substitute yet for individual judgment, taste, or listeners' reactions, which are the principal guides in achieving the optimum

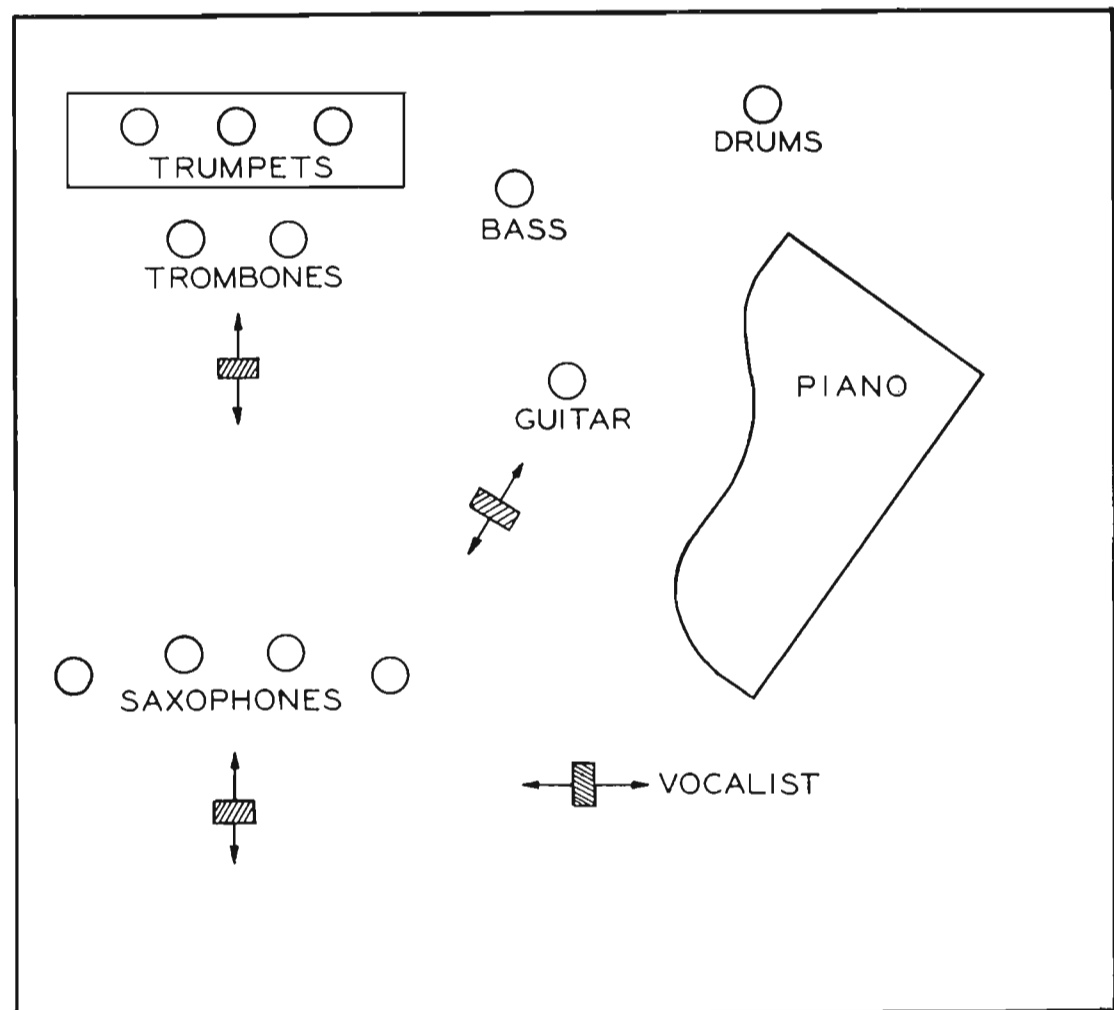

FIG. 14 (above). Typical arrangement for dance orchestra.

results. The success of every broadcast depends on sound fundamental principles intelligently applied with flexibility and originality, taking full advantage of every technical advance to meet the needs of a particular situation. In this way, only, can the skill in technique of broadcasting keep pace with the engineering developments so frequently being provided.

The author wishes to acknowledge the generous help of the NBC staff and is particularly indebted to Rinehart and Company for permission to reproduce Figs. 9 to 15 from their current book "Broadcasting Music," by E. La Prade (1947).

Thanks are hereby extended to Audio Engineering for artwork and additional material.

FIG. 15 (below). Microphone pickup for dance orchestra with strings and a vocalist. A—Principal microphone. B—Vocalist's microphone. Other microphones for group accentuation.

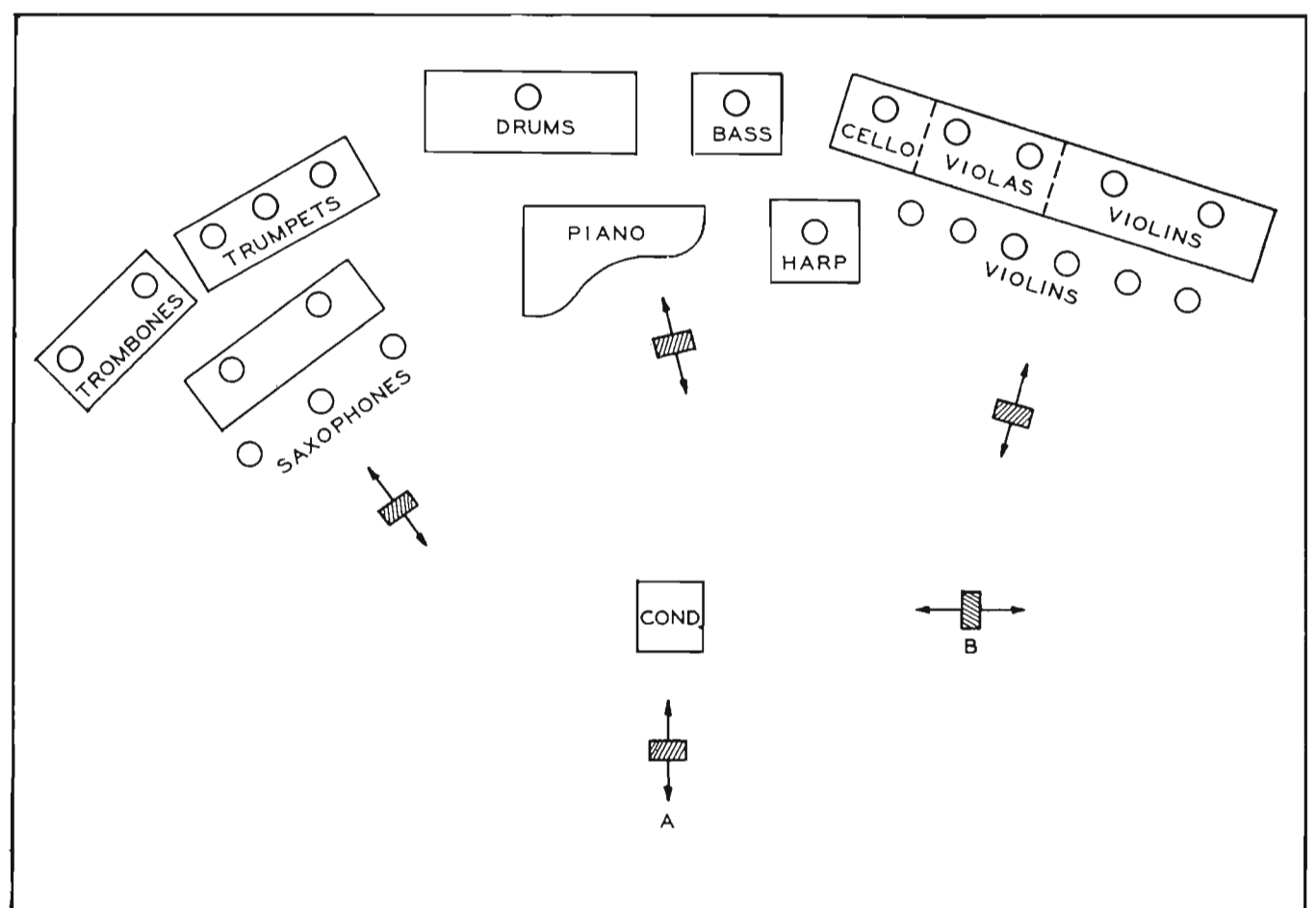

# ABC BRINGS OPERA TO HOME FOR FIRST TIME

Television history was made at the Metropolitan Opera in New York Monday night as the American Broadcasting Company trained its cameras on the stage of the opera house to bring a full-length performance of Verdi's "Otello" to the viewing screens in hundreds of thousands of homes along the eastern seaboard. "Otello" heralded the opening of the Met's new season and...

Copyright, 1948  
New York Herald Tribune Inc.

# Video Brings Met Opera To Vast New Audience

'Experiment' Success As History Is Made

Mink and Ermine Featured at Opening

Illustrated on Page 20

## TELE TOPICS

THE ABC PICKUP of the opera Monday night garnered a 42.3 Hooper in New York City between 8 and 10:45 p.m., with sets-in-use. Rating was 59.8 per cent and 70.8 hour, 44.6 for the second and 41.3 for the last 45 minutes. Highest share was recorded after 10 o'clock, when WJZ-TV had 60.7 per cent of all sets in operation; highest sets-in-use figure was reported for the 9-10 p.m. period.

HLOSS  
opera Associa-  
the American  
ed forces last  
tic history by  
cast of a full-  
en in the 350-  
ric stage.  
the opening of  
64th season  
pany's historic  
st. and Broad-  
al social glamor  
d a superb per-

## 'OTELLO' VIDEO CALLED SUPERB

Opera's First Television Gets High Praise.

## 'Otello' Opens Opera Season, Video Adds Vast New Audience

Metropolitan's 64th Night; Margaret Led by Wond

Virgil Th

By Herbert Kupferl  
The Metropolitan Opera  
its sixty-fourth season la  
with a capacity

# OPERA STORY

## OPERACASTING

By BRUCE ROBERTSON  
See pictures, page 38; editorial, page 50

TELEVISION history was made last Monday when ABC, with the cooperation of the Texas Co. and the Metropolitan Opera Assn., successfully brought off television's most ambitious experiment—a full length telecast of Verdi's "Otello" direct from the stage of the Metropolitan Opera House in New York.

To this televiewer, at least, the experiment proved opera to be good television entertainment. A program that can hold an audience for well over three hours doesn't have to argue.

The ably sustained range,

as they are to auditorium, and most of reduced to the viewing screen. When the entirely brings five feet of home audience over that in.

Fourth Because nique, televi and final ac spot of the with Desde

## 'Otello' Makes TV History

## 'Otello' Opens Metropolitan; Opera Televised First Time

Traditional Sparkle Marks Start of Season That Once Was Cancelled—Advance Sales Indicate Near-Record Year

By HOWARD TAUBMAN

Surmounting a crisis that last summer had imperiled its

cal difficulti  
rew.  
we  
nute  
sal,  
ent,  
loc  
ng  
oo  
ir  
he  
sw

In the subsequent acts, the picture quality was immensely improved, and the last act, which also is dim on the stage, was transmitted well; Desdemona's "Ave Maria" was highly effective.

An opera fanatic, especially imported into one television home for the evening, expressed gratification with the broadcast as a musical experience, and testified to this not only with words, but with actions, leading the music and listening and watching raptly.

## Watched by Thousands.

Those who watched by television were numbered by many thousands. The Eastern American Broadcasting Company represented here by WJZ carried the broadcast, which began at 8 p. m.

Now they can look to enjoying opera at the favorite chair, with a glass at hand, is about. They can, the more such broadcasts aired. Dat' debut, at makes this ques- cost: a good \$20,000 and the opening, Texas Company, the broadcast, the only unobtrusive could find a way of watchers, ABC e that amount, advance bring the opera be ope

THE NEW YORK TIMES, TUESDAY, NOVEMBER 30, 1948.

THE METROPOLITAN OPERA HOUSE LAST NIGHT

## TELEvised OPERA EXCITING TO VIEW

Video Debut, Despite Technical Handicaps, Presents 'Otello' Show in Intimate Detail

By JACK GOULD

television of the Metropolitan Opera's opening performance last night was an exciting and rewarding achievement and the Verdi masterpiece being brought into untold hundreds of thousands of homes with a new and arresting quality of intimacy. The implications in the first five minutes of the video art and the operatic find were self-evident to the televiewer sitting miles away from the opening night at Thirty-ninth Street. The view of "Otello" that came into one's living room frequently was more detailed and more revealing than that obtained from a seat "down front" in the Metropolitan auditorium.

As was emphasized by both the audience and the Broadcasting Company, the broadcast was completely darkened s

## Video Gives Opera to Vast Audience

By EDWIN H. SCHLOSS

Continued From First Page  
from ABC stations in Boston, Baltimore and Washington, D. C.

It was a fascinating project and it was history striding in the right direction—that of disseminating and democratizing an art which in the past has been, traditionally (at least in this country) on the exclusively plushy side.

growing pains. The visual images ranged from excellent to spotty, due in part to picking up the show from the stage without the advantage of studio conditions. But the musical reception was excellent. And Verdi's score with its sovereign dramatic power and lyric beauties swept everything triumphantly with it.

Last night's pioneering telecast was frankly announced as "an experiment." But where was

Rembrandtesque highlights and shadows. With the ability of three cameras to shift with the action, the dramatic aspects of the opera could be and were underlined in a sort of visual counterpoint that aided the illusion immensely and sharpened the drama.

## ILLUSION ACHIEVED

"Otello" is an opera that responds magnificently

VIDEO SERVED MILLION  
It was estimated that 450,000 television receiving sets in the

# ABC PIONEERS WITH MET TV

“Otello on television last night (November 29) was good. Considering technical difficulties of the opening night broadcast from the Metropolitan Opera House, it was excellent. Considering that this was the first attempt to put a full regular performance on the air from there or any other theatre, it was superb.”

So said Dan Anderson writing in the *New York Sun* the following day. And so said several dozen other music, drama, and radio critics in big metropolitan dailies up and down the eastern seaboard.

Most of these reviewers, as reviewers will, went on to venture their prophecies as to the place of opera on TV, the effect of TV on opera, the future of opera and

even the future of TV. Their speculations would form the basis of an interesting discussion—and we could even add some ideas of our own. But we won't. *BROADCAST NEWS* is dedicated to the operations end of broadcasting—and so we'll confine the story which follows to a description of how the ABC engineering and production staffs went about making what *Broadcasting* magazine called “television's most ambitious experiment.”

That the opera telecast was more than an experiment is proved by the careful way the ABC staff tackled the job. Nevertheless, it was a pioneering endeavor and this is well-indicated by the fact that at least four important firsts were established by this operation, including:

- (a) The first telecast from the Metropolitan.
- (b) The first telecast of a full-length opera.
- (c) The first use (for this purpose) of infra-red light.
- (d) The first use of eight cameras at one time.

The story of how it was all carried out with precision and with great success is one which we think is of great interest and which deserves description at some length.

## Working Under Difficulties

As if the televising of a full-length opera were not problem enough, the ABC engineers had hardly started on their planning

FIG. 1 (below). Interior of the Metropolitan Opera House during the opening night performance of “Otello.” Arrows indicate positions of the four cameras used in the auditorium proper.

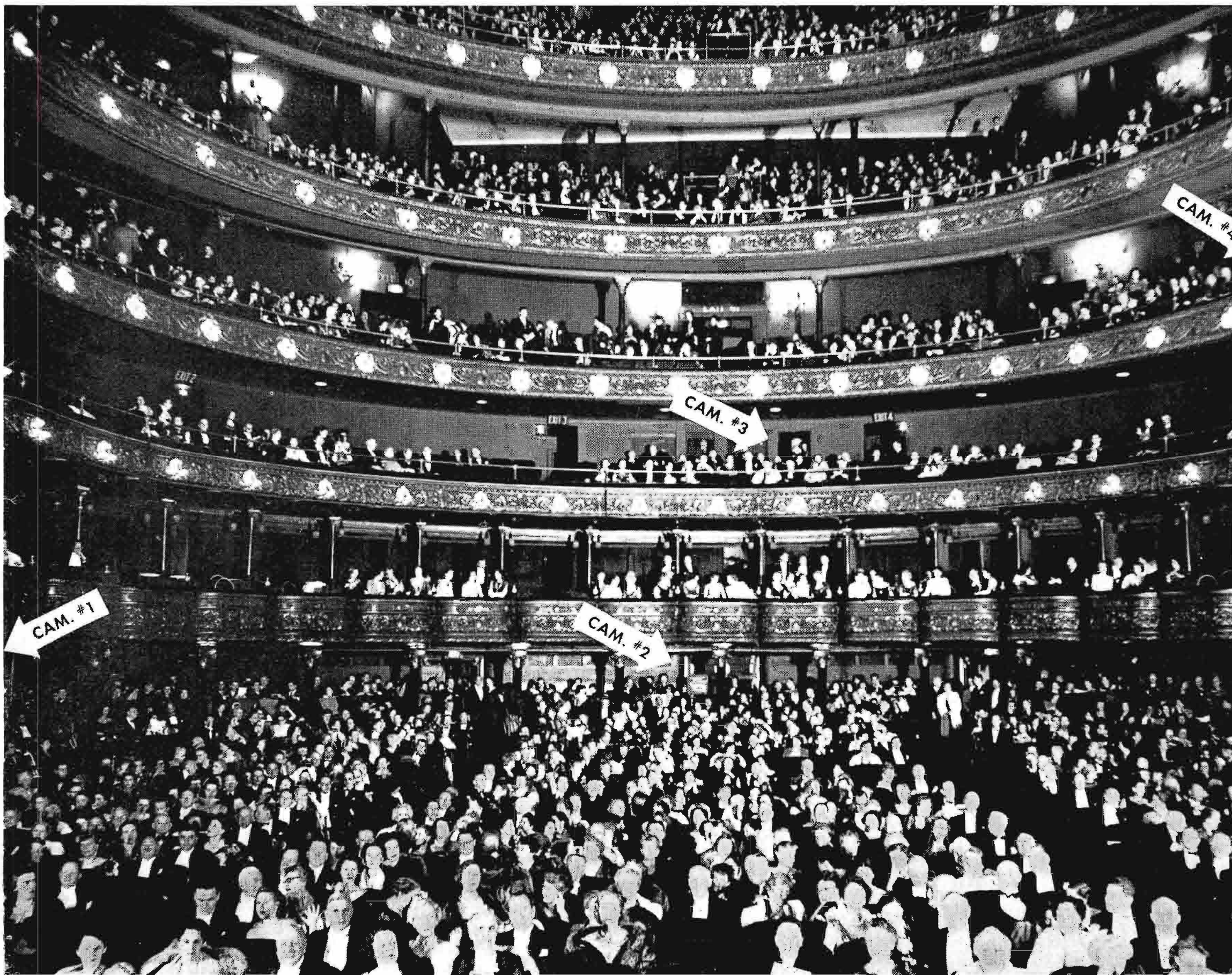



FIG. 2 (left, above). Crowds surging into the Opera House threatened to engulf the camera crews. This is the main entrance on 39th Street just before curtain time.

FIG. 3 (left, below). Members of camera crews, as well as announcers had to "dress" for the occasion. This view shows George Hicks and camera operators in main lobby.

view. They can't make any noise. They can't have lights on them. No, you can't remove any seats—the house has been sold out for months."

What it amounted to was that television could come in providing it kept so far in the background that no one, artists or audience, knew it was there. And ABC's engineers honestly tried to make it so. In the end, however, it was a futile effort—for, as it turned out, every one, artists as well as audience, was tremendously interested in the TV operations.

#### Use of Infra-Red

The biggest problem was how to get sufficient lighting for good TV pictures. "Otello" is particularly difficult in this respect in that this opera has several scenes in which the illumination is very low, and one (the opening scene) in which the stage is almost entirely dark.

The solution to this lighting problem is one of the outstanding accomplishments of the opera telecast—and possibly the development portending the most for the future. In retrospect it seems almost too easy. ABC engineers, realizing they could not use visible light, decided almost in desperation to try "invisible" light. Knowing that the 2P23 Image Orthicon is particularly sensitive in the infra-red region (and remembering that infra-red light had on occasion been used for trick pickups in darkened rooms) they decided that if they could bathe the stage with infra-red "illumination" they could get a good pickup no matter how dark the stage was to the eye.

The decision to try infra-red was followed by a frantic period of experimenting in the laboratory. Quick tests indicated the scheme would work. But there was not time for careful tests—or quantitative measurements. And, worst of all, there was no opportunity for rehearsal or even for a full scale test of the lights by themselves. When the curtain went up no one actually knew for sure whether or not there would be a picture.

#### How It Was Done

The arrangement of infra-red lights was extremely simple. There was, of course, not time to obtain special lights or to experiment at length in the theatre itself. However, it was found that ordinary 1,000



before they found that they would have to work under the most irking restrictions. Although tentative approval for the telecast had been obtained months before, the engineers sent to survey the situation were at first refused even permission to inspect the Opera House. "You just can't do it," they were told. When they finally did talk

their way into the hallowed premises they found themselves up against traditions and fixed customs which were impossible to change. "You can't change any scenery," they were told. "You can't change any costumes. You can't change the lighting. You can't change the artists' makeup. Your cameras cannot interfere with anyone's

FIG. 4 (right, above). Slides were used by network, before program time and during intermissions to provide identification and promote the "premier" feeling.

FIG. 5 (right, below). Scene from the first act as photographed from kinescope screen. Home viewers, as several critics observed, had a better view than most of those in the Opera House.

watt incandescents could be provided with simple gelatin filters which cut out practically all visible light, while transmitting most of the infra-red spectrum. Thirteen of these lights, mounted in ordinary "scoops" with filters, made up the battery which was actually used. These lights were placed at intervals between the regular footlights and were left on all during the program.

#### Effectiveness of Infra-Red

The effectiveness of the infra-red battery apparently surprised even its originators. The opening scene of "Otello" takes place during a storm at night. In this scene there is almost no light on the stage. Milton Cross, in his pre-curtain synopsis of the first act, went to some lengths to warn the TV audience that the opening scene was dark, and that they would probably see nothing on the receiver screen for several minutes. Actually, when the house lights went out and the curtain rose the TV audience saw on the receiver screen a scene which looked more like daylight than dark. The engineers had overdone it—they had too much illumination. After the stage lights came up the only effect of the infra-red was a slight over-illumination of the lower part of the sets. In later acts the infra-reds were dimmed somewhat, and by the last act a balance was achieved that seemed to please almost everyone.

#### Installation Problems

Aside from the lighting, and the problem of locating the cameras (see below) the next biggest problem was that of installation. Although some preliminary work was done a few days before, the greater part of the installation was made on the day of the broadcast. To accomplish this a crew of eight men worked all day long to install the approximately 6000 pounds of equipment and 4000 feet of connecting cables. The magnitude of this job is only partially indicated by the description of the equipment layout which follows.

#### Eight Cameras Used

The "camera concentration" at the Met opening probably exceeded anything to date. In order to provide for complete coverage, not only of the stage presentation, but also of all the side activities, ABC engineers wheeled eight (yes, we said *cight*) cameras—all RCA TK-30A's—into action. So far as we know this is the most "live"



TV cameras that have ever been fed into one mixing system. There were, of course, more cameras than this at the Philadelphia Convention—however, there were never more than five in action at a time on any one network.

ABC's experience indicates that although a satisfactory pickup could be made with

a few less cameras (perhaps five or six) the availability of the full battery of eight is desirable in order to provide flexibility and freedom from embarrassment in case of a camera failure. It is interesting to note that ABC engineers had predicted beforehand that because of the close operating quarters, milling crowd and other

# Televised Opera Exciting to View

(Reprinted from the NEW YORK TIMES for Nov. 30, 1948)

by JACK GOULD

The televising of the Metropolitan Opera's opening performance of "Otello" last night was an exciting and rewarding achievement, the Verdi masterpiece being brought into untold hundreds of thousands of homes with a new and arresting quality of intimacy.

The implications in the first fusions of the video art and the operatic field were self-evident to the televiewer sitting miles away from the opening night hubbub on Thirty-ninth Street. The view of "Otello" that came into one's living room frequently was more detailed and more revealing than that obtained from a seat "down front" in the Metropolitan auditorium.

As was emphasized by both the American Broadcasting Company, which carried the television broadcast over its Eastern video network, and the Metropolitan Opera, last night's video production was intended purely as a tryout because it had to be executed under a variety of technical handicaps.

Since the video production could not benefit from many special preparations without interfering with the performance for the audience at the Metropolitan, compromises had to be made. The lighting was often erratic and given to extreme of brightness or darkness. The distant "shots" from the back of the house also reduced the principals on stage to microscopic proportions.

The truly triumphant moments in the telecast came when the cameras forgot the conventional proscenium arch, which separates the player and the audience, and appeared to move directly "on stage" for its pick-ups.

The lyric tenderness in the love scene between Otello and Desdemona at the close of the first act gained an added effectiveness from the fact that Ramon Vinay and Licia Albanese seemed almost at arm's length from the televiewer. Too, when Iago cunningly implants in Otello's mind the thought that Desdemona was unfaithful, the

close-up made it seem highly personal to the looking listener.

In the last act, the camera work reached perhaps its greatest proficiency, chiefly because the action on the stage was not diffused over the large stage but centered on Desdemona's bed. Her solo rendition of the "Ave Maria" at her prayer bench was an exceptionally moving visual cameo.

The weakness in the excessive use of distant "shots" was most vividly exemplified in the third act, when Iago takes Desdemona's handkerchief from Cassio and waves it so that Otello may see it. The scene demanded a close view but, through lack of alertness on the part of the video director, the handkerchief could hardly be seen at all in the view shown.

The "Otello" telecast represented the first time that any stage production had been televised in its entirety from a theatre. If anything, the presence of the audience and the intangible excitement and nervousness of the first night emphasized the quality of immediacy

that is video at its most effective.

During the intermissions, the cameras went backstage to show the changing of the scenery and to pick up brief interviews with the principals of the cast. These interludes were marred, however, by the somewhat banal questions asked by the interviewers. Someone familiar with backstage proceedings could have added importantly to the audience's understanding of what was transpiring.

Whether there will be further telecasts of Metropolitan Opera performances appeared last night to hinge primarily on the matter of costs. Most of the cast received double pay because of the television pick-up and the other craft unions also received increased compensation for the evening. In all, the added expense amounted to nearly \$20,000, a figure which, it was said, could not be met on a regular basis because of video's still comparatively limited audience. Last night's performance was sponsored by the Texaco Corporation.

restrictions it would be impossible to repair or replace cameras which failed during the program. It was planned that any camera which failed would simply be disconnected and operation continued within the remaining units. This meant, in effect, that all scenes of importance should preferably be covered in duplicate (that is from at least two cameras).

## Camera Locations

Location of the eight cameras is indicated in Fig. 6. It will be noted that one group of four cameras was used to pick up the stage presentation, the second group of four were used for side activities. The four cameras in the auditorium proper were located, not where the producer and engineers would have liked to have them, but rather in the only positions available—positions which in many respects were far from ideal. As noted previously the management was adamant in its insistence that no camera could be placed where it would interfere with the view of any part of the audience. This immediately ruled out any possibility of the "down front" camera locations ordinarily used for stage presentations. Moreover, the whole house was "sold out" weeks in advance so that no seat space could be pre-empted. This ruled out desirable balcony spaces which could have been utilized if only a few seat-spaces could have been used for camera locations.

The camera locations finally decided upon were as follows: Camera #1 was placed in the "standee" section behind the last row of seats on the right side, 250

feet from center stage (with 800 feet of cable to the control room); Camera #2 was also in the "standee" section, but in this case in the rear center, 300 feet from center stage (with 700 feet of cable to the control room); Camera #3 was placed in the AM control booth at the rear of the Grand Tier, 300 feet from center stage (with 250 feet of cable to the control room); Camera #4 was in a box at the left of the 2nd balcony, up close to the proscenium, 60 feet from center of stage (with 300 feet of cable to the control room). There was also a camera backstage 50 feet from center stage (with 500 feet of cable to the control room). In addition to the above-mentioned cables, 1,200 feet of audio cable was also used.

Of the four cameras dedicated to pickup of side activities one was placed on a two-foot high platform in the main entryway in order to pickup opera patrons making their traditional and colorful entrances. A second was placed on a small mezzanine overlooking the smoking lounge, the third in a small room off the lounge, and a fourth in a busy spot backstage. As it turned out, the position overlooking the smoking lounge was not satisfactory due to the fact that the light from a huge chandelier, together with a haze of smoke in the room, almost wiped out the images. The room off the lounge was used for interviews with prominent guests and for pickup of Milton Cross' commentary. But the most striking results were obtained with the backstage camera in between-the-acts interviews with members of the cast, members of the Met

organization, stagehands and others. These interviews were notable for their informality and the interest (in TV) of the people interviewed. Stagehands and scenery movers were all around and even passed occasionally in front of the camera. One reviewer seemed to think this was undignified and distracting, however, our own feeling and that of many others was that the noise and bustle added interest to what could otherwise have been a rather dull intermission.

## Camera Handling

A number of the reviewers, in commenting on the opera telecast, mentioned the good camera work. This is certainly a tribute to both the camera men themselves and to Burke Crotty, ABC Production Director, who called the shots—for seldom, if ever, have they worked under more restricting conditions. To begin with, the camera positions themselves were such that dollying (a favorite device to provide action in picking up singers) was out of the question. Moreover, the camera locations (with the exception of that in the 2nd balcony) were so far away from the stage that telescopic lenses had to be used most of the time. Use of these lenses makes even simple panning difficult (because the effect of camera movement is so exaggerated). As a result, camera action was largely a matter of switching from one camera position to another and of changing lenses in between switches in order to provide variety.



# ABC'S VIDEO FACILITIES FOR OPERA TELECAST

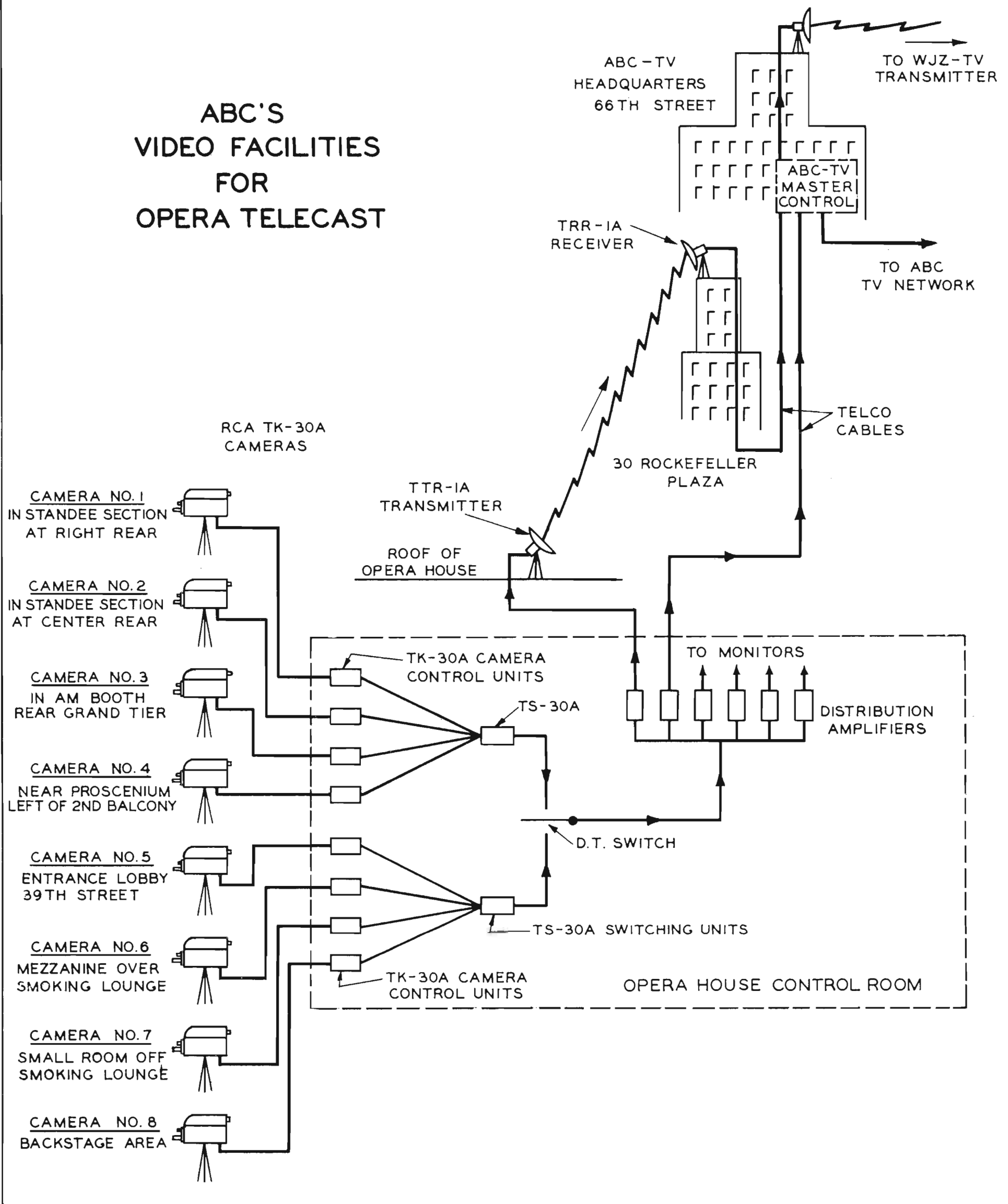

FIG. 6. Simplified schematic diagram of video facilities setup by ABC engineers for telecasting from the New York Metropolitan Opera House. Eight RCA cameras were connected by camera cables to eight camera control units located in the control room. Outputs of the camera controls were fed into two TS-30A switching units, as shown. The arrangement of cameras' mixing circuit was such that one group (Nos. 1, 2, 3 and 4) were in use during actual program, while the other group (Nos. 5, 6, 7 and 8) were in use before curtain time and during intermission. The output of either switching unit could be selected (by means of a double-throw switch) for transmission to the monitor system and transmitter lines. Two alternate methods of feed to the ABC TV headquarters at 66th Street were established in order to provide maximum insurance against program interruption.

Actually the problem of portraying a complete visualization of the action was considerably harder than might be supposed. In this opera a large cast is used and there are times when as many as eighty people appear on stage at once. Moreover, they are not grouped in fixed positions, but tend to move in almost random fashion about the stage. In order to focus attention on the principals, the director must use closeups much of the time. However, to "locate" these closeups in the overall scene he must intersperse wide angle shots at frequent intervals. To do this without seeming to "jump about" requires a fine directorial touch. It is particularly difficult when all of the cameras view the scene from different angles. Several reviewers mentioned the fact that the "shots" from the balcony camera (which almost overhung the stage) were the "most striking" and this was certainly true. However, the angle of this camera was so different that at times the scene it portrayed was very different from that of the more straight-on cameras, with the result that switching back and forth between it and the other cameras was a bit confusing to the viewer—particularly to those who were unacquainted with the opera and hence had some difficulty following the action under even the least-confusing conditions.

In talking to Mr. Crotty about this matter of camera switching we raised the question of whether use of fades and superpositions might not have helped. His answer was a quick and emphatic no. He went on to point out a factor we hadn't thought of, namely that to use superpositions, or even fades, would be to add "artistry" or "illusion" that was not envisaged in the carefully planned presentation—and that such gilding would be questionable taste.

### Control Room Equipment

Fig. 6 is a simplified diagram of the video facilities used by ABC at the Met. The camera and control equipment consisted essentially of two complete sets of RCA field equipment plus extra distribution amplifiers required for feeding a large number of monitors and two outgoing lines to the studio.

In the control room itself were eight camera control units—one for each of the eight TK-30A cameras. These were arranged in groups of four—each group feeding into the four camera input positions on an RCA TS-30A Switching Unit. The outputs of the two switching units were connected to a double throw switch. Thus the output of any one of the eight cameras could be selected for transmission to the house monitors and outgoing lines.

The technical crew assigned to the control room included four video operators (each of whom handled two camera controls), one audio operator, one maintenance man and the technical director. Also in this room were the producer, two assistant producers and a music prompter. Thus the total control room personnel was eleven people. The control room was too small for the size of the operation. The temperature soon rose to 120° and remained thus during most of the telecast. Nevertheless both personnel and equipment came through the ordeal without major difficulty.

### Arrangement of Lines

In order to reduce the possibility of program interruption both audio and video circuits to the master control room at ABC's 66th Street TV headquarters were provided in duplicate. One video circuit (Fig. 6) consisted of a telephone cable directly from the Opera House to 66th Street. The other video circuit was made up of a microwave link from the roof of the opera house to Radio City, and from there to 66th Street via the regular telephone cable connection. Audio circuits similarly included one line directly to 66th Street and second by way of the Radio City studios. From the ABC master control room the program was fed over AT&T coax to stations on the ABC Eastern Network, and by way of ABC's regular microwave link to the WJZ-TV transmitters on the roof of the Hotel Pierre. This microwave link, as well as that from the Opera House, uses standard RCA TTR-1 and TRR-1 Relay Equipment.

### Program Recorded on Film

The "Otello" telecast was also an opportunity for ABC to try out their brand new RCA film recording equipment. This equipment includes a special monitoring kinescope mounted in an enclosure to which is permanently mounted a camera especially designed for photographing the images as they appear on the face of the kinescope. The RCA equipment may be used for either the "single" system or "double" method of recording (in the "single" system, audio and video are recorded together; in the "double" they are recorded separately). ABC uses the "single" method. The monitor, camera and soundhead housings are permanently mounted on a standard RCA pedestal which houses driving circuits, amplifiers, auxiliary equipment and controls.

It is interesting to note that ABC, wishing to make doubly sure of having a good print of this important event, decided to engage an outside firm to make a separate film recording for them. Thus if their own was not too good, perhaps the film made

outside could be used. As it turned out, the other firm called up eight minutes after the start of the program to say their equipment had broken down. This left the already harried ABC crew with the knowledge that they must turn out a good film—or else. To make a long story short, they did. We had an opportunity to see some of this film and our own feeling was that it provided a better picture than we received in Philadelphia by cable.

### Equipment Failures

Inasmuch as a number of writeups of the opera telecast have given rather exaggerated impressions of equipment failures it might be well to set the record straight with the true facts.

The actual failures were just three in number. First, the camera in the entrance "conked out" just as the crowd was starting to come in. At the time the lobby was so jammed with hundreds of people milling about that it was impossible to replace this camera or to service it. It was later found that the difficulty was due to a break in the connecting cable. (This is something which under ordinary circumstances would probably have been quickly located and remedied.) In the emergency the inside cameras were used to show people coming in and taking their seats—which was probably just as impressive to lookers-on, if not more so.

The second failure occurred during the third act when the pickup tube in one of the cameras in the standee section went soft. The burden was carried by the other three cameras and very few of the television audience noticed the difference.

The third failure and the only one that occurred in the control room—despite the large number of units and the 120° temperature—was a small tube in one of the scope units. This was located and replaced in a few minutes. During the interval the operator (really using his head) got the transmitter on the phone line and had them give him instructions for riding gain (which he could not do directly with his monitor dead).

In general it is the feeling of ABC engineers, and ourselves too, that considering the difficult operating conditions, the lack of rehearsals, and the short time for setting up, the equipment performed very well.

The overall operation was under the supervision of George O. Milne, ABC's Director of Technical Operations, and William R. Ahern, New York Television Operations Supervisor, and credit should also be given to Jack Stody, Television Field Supervisor, Walter Kubilus and Robert Massell, Technical Directors on the opera origination.

# THE PHILOSOPHY OF OUR TV SYSTEM

**A Brief Review of the Functions of the Most Important Parts of the TV System, With An Explanation of the Reasoning Behind the Choice of Standards, Type of Transmission, Shape of Synchronizing Pulse, Etc.**

by **JOHN H. ROE**

Supervisor, TV Systems Engineering Group  
Engineering Products Department

## Introduction

The boom in television has created a need for trained operators which is far in excess of the available facilities for training them. As a result, many stations face the start of regular operating schedules with a staff of inexperienced (in TV, that is) operators who, although they have been briefed in their duties, have only a beginner's knowledge of the overall TV system.

No amount of written description can provide the background which several months of operating experience can give, nor can a story of the system, complete in every detail, be set down in a few pages. However, it is felt that a recapitulation of some of the basic philosophy of the television system will be helpful to many of the beginners in the business, and may prove an incentive to further reading. Therefore an effort will be made to review briefly the functions of some of the important parts of the system and explain the thinking behind them. Detailed discussion of circuits and methods is purposely omitted in order to devote the space to an overall picture of the system. References to other papers covering much of such detail are given in a bibliography.

## Limitations

No true appreciation of any system can be realized without some understanding of its basic limitations, and a discussion of the television system should therefore begin by reviewing these. The most serious limitation of a television system, as in the case of an aural system, is "noise." The same phenomena that cause hum, crackle, and hiss in the background of a sound broadcast, cause bar-like shadows, random

blotches, and "snow storms" in the background of a television picture. The word, noise, has been carried over from aural terminology into television terminology with the same connotation. In other words, any spurious elements in a television picture are generally called noise. In reading the following discussions, it will be helpful to remember that much of the reasoning behind the methods used in the television system is based on the need to minimize the effects of noise.

Spurious noise components in the signal arise from two general sources, (a) shot noise and thermal agitation in vacuum tubes and other circuit elements, and (b) pickup from associated or remote electrical apparatus. The best means for minimizing noise is to maintain a high signal-to-noise ratio in all parts of the system, but where this is impossible, special circuits are a distinct aid in extending the useful range of operation.

Noise limits, among other things, the ability of the system to resolve fine detail. However, a more direct limitation on the resolving power of the system is the frequency bandwidth available in the transmission system. This limitation has commercial aspects of more significance than the technical aspects because of the limited room available in the radio spectrum. As a result, the decisions of the Federal Communications Commission effectively determine the limits of resolution within the noise-free service area of any station. Through long years of field testing it has been found that a six-megacycle channel will provide adequate resolution and at the same time will yield a reasonable number of channels.

Other factors which limit overall performance are the fineness of scanning aper-

tures,\* the degree of accuracy with which tonal gradations are reproduced, and the brightness range of which the reproducing device is capable. However, if it can be assumed that the transmission system between the pickup and reproducing devices is reasonably linear, then the problems arising from these particular limitations are confined largely to the pickup and reproducing devices themselves, and do not affect system considerations to the same extent as limitations described in the preceding paragraphs, and as certain economic factors do.

Economic factors usually limit the degree to which technological development is used to improve the quality of performance. Methods may be known by which some of the physical limitations of the system can be overcome, but sometimes such methods are not used for a long time after their discovery because means for applying them economically are not developed simultaneously. In other words, their use increases the cost of equipment excessively. This is especially true in the case of receiving equipment which must be produced in large quantities at low unit cost. Such methods often do find their way into trans-

\* The use of the word *aperture* in television probably arose from the use of scanning disks where the light passed through small holes which traversed the projected area of the scene. Small holes traversing closely spaced lines in the area were capable of greater resolution than larger holes traversing more widely spaced lines. Though scanning disks are no longer used, the term *aperture* is still applied to the scanning device in a general sense. In electronic television, the diameter of the "aperture" is simply the diameter of the scanning beam of electrons in the plane of the scanned image. Similarly the term *aperture correction* is applied to means (usually the use of special circuits) for compensating the picture signal for loss of resolution caused by finite size of the beam and by non-uniform distribution of electrons over the cross-sectional area of the beam.

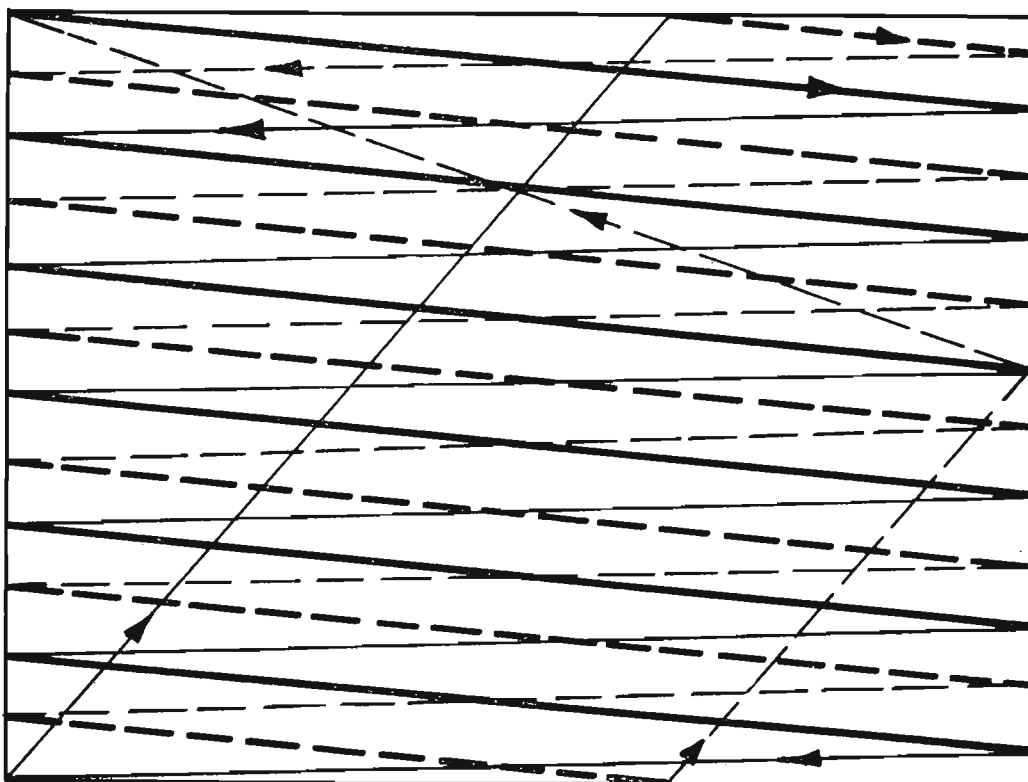

FIG. 1. Odd-line interlaced scanning system with 13 lines. Consecutive fields are indicated by solid and dotted lines, respectively.

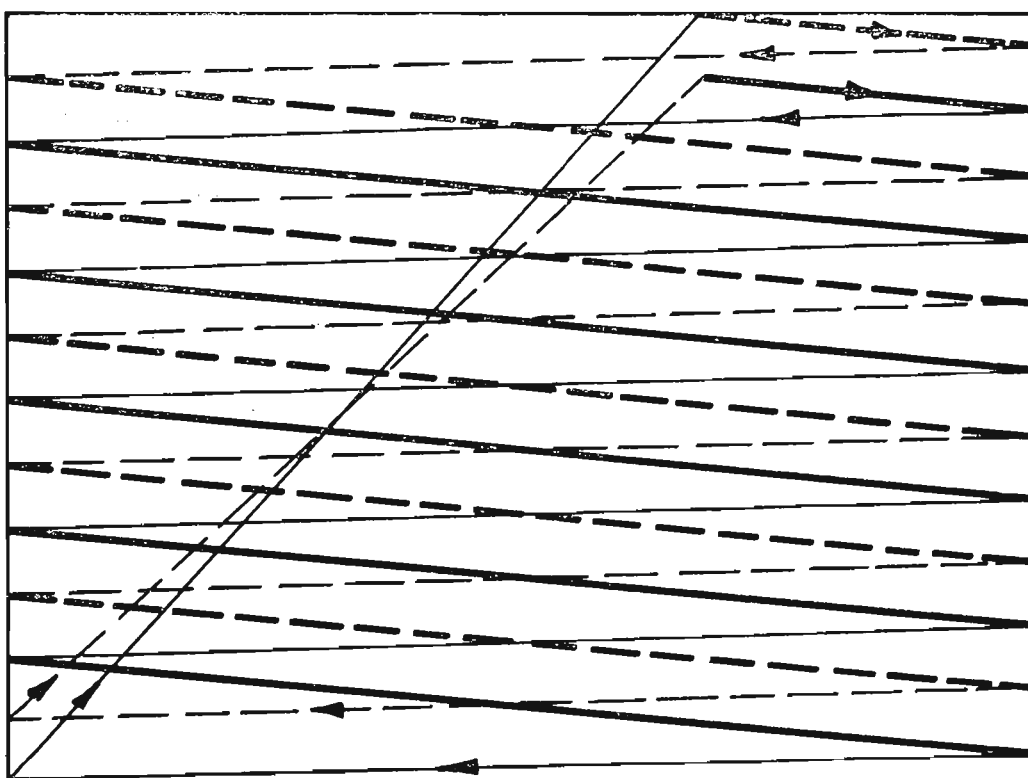

FIG. 2. Even-line interlaced scanning system with 12 lines. Consecutive fields are indicated by solid and dotted lines, respectively.

mitting equipment where low unit cost is not so important and where quality of performance is paramount. Quality is stressed in transmitting equipment to provide reliability and to reduce the need for including in the receivers complicated and expensive corrective circuits. Examples are circuits for automatic correction of scanning linearity, and clamp circuits for accurate re-establishment of black level, or d-c restoration, as it is often called.

#### Standards

During the decade preceding the entrance of the United States into World War II, Radio Corporation of America

carried on an extensive program of research and development in television and the information so derived has been largely responsible for the formulation of the standards governing our present black-and-white system. The earliest work on standards was done through the medium of the Radio Manufacturers' Association. Much more extensive work on standards was carried on later by the National Television System Committee and the Radio Technical Planning Board, the former body being set up to deal exclusively with television standardizing problems and to bring about agreement among the several interested groups on suitable standards for

recommendation to the FCC. With the approach of commercial broadcast service, the FCC adopted the recommendations of these bodies as the basis for tentative standards of good operating practice. Activity of the RMA has continued on television and its recommendations have been extended to cover much of the detail of studio and transmitter operation, and of receiver design. While a considerable portion of this material still exists only in the form of recommendations to the FCC, it will undoubtedly constitute the major part of the final standards.

One of the most important standards recommended is the one which describes the wave shape of the picture signal. This standard is outlined in detail in a drawing which is reproduced in Fig. 5. Reference will be made to this drawing from time to time in discussing the system, and an attempt will be made to clarify the reasoning involved in establishing many of the specifications included in it.

#### Scanning System

The standard system of scanning in television is one in which the scene or image is traversed by the aperture in lines which are essentially horizontal, from left to right and progressively from top to bottom. The aim is to have the aperture move at constant velocity both horizontally and vertically during actual scanning periods because that is a simple type of motion to duplicate in the reproducing aperture and because it provides a uniform light source in the reproducer. At the end of each line the aperture, or scanning beam, moves back to the start of the next line very rapidly. The time occupied by doing this is called the *fly-back* or *retrace* period. In a similar way, the beam moves from the bottom back to the top after the end of each picture scan. Motion during retrace periods need not be linear. The complete traversal of the scene is repeated at a rate high enough to avoid the sensation of flicker. This rate has been set at 60 times per second because most of the power systems in the United States are 60 cycle systems, and synchronization with the power system minimizes the effects of hum and simplifies the problem of synchronizing rotating machinery in the television studio (film projectors) with the scanning.

It has appeared rather recently that the choice of 60 cycles for the vertical scanning frequency was a fortunate one for another reason. The progress of the art

has included means for obtaining brightness levels in the reproduced pictures which are appreciably greater than those used in motion picture theatres. It is well known that the threshold of flicker increases as the brightness increases. Thus, 48 or 50 cycle flicker would be noticeable to some observers at modern brightness levels in television receivers. Persistence of vision varies in different people and those whose persistence characteristics are very short are conscious of the 60-cycle flicker in the bright pictures on some present-day receivers. Therefore it appears that a still higher vertical frequency would be desirable if other factors would permit. Needless to say, the interline flicker, mentioned later in connection with interlacing is also less objectionable with the higher scanning rate.

Another important factor affecting flicker is the persistence characteristic of the screen material in the receiver. This can be made long enough to overcome any appearance of flicker even with scanning rates less than 50 cycles per second, but, if carried too far, such long persistence causes ghost-like trailing after moving objects in the scene. Judicious choice of screen persistence is a great aid in reducing flicker.

Obviously the scanning apertures in the pickup and reproducing parts of the system must be in exact synchronism with each other at every instant. To accomplish this, synchronizing information is provided in the form of electrical pulses in the retrace intervals between successive lines and between successive pictures. The retrace intervals are useless in reproducing picture information, hence are kept as short as circuit considerations permit, but are useful places in which to insert the synchronizing pulses. These pulses are generated at the studio in the same equipment that controls the timing of the scanning of the pickup tube, and they become part of the complete composite signal which is radiated to the receiver. Thus scanning operations in both ends of the system are always in step with each other. Synchronizing is discussed in more detail in a later section.

The number of scanning lines is the principal factor determining the ability of the system to resolve fine detail in the vertical direction. The number of scanning lines is also related to the resolving power in the horizontal direction because it is desirable to have the same resolution in both directions. Thus, as the number of lines increases, the bandwidth of the system must

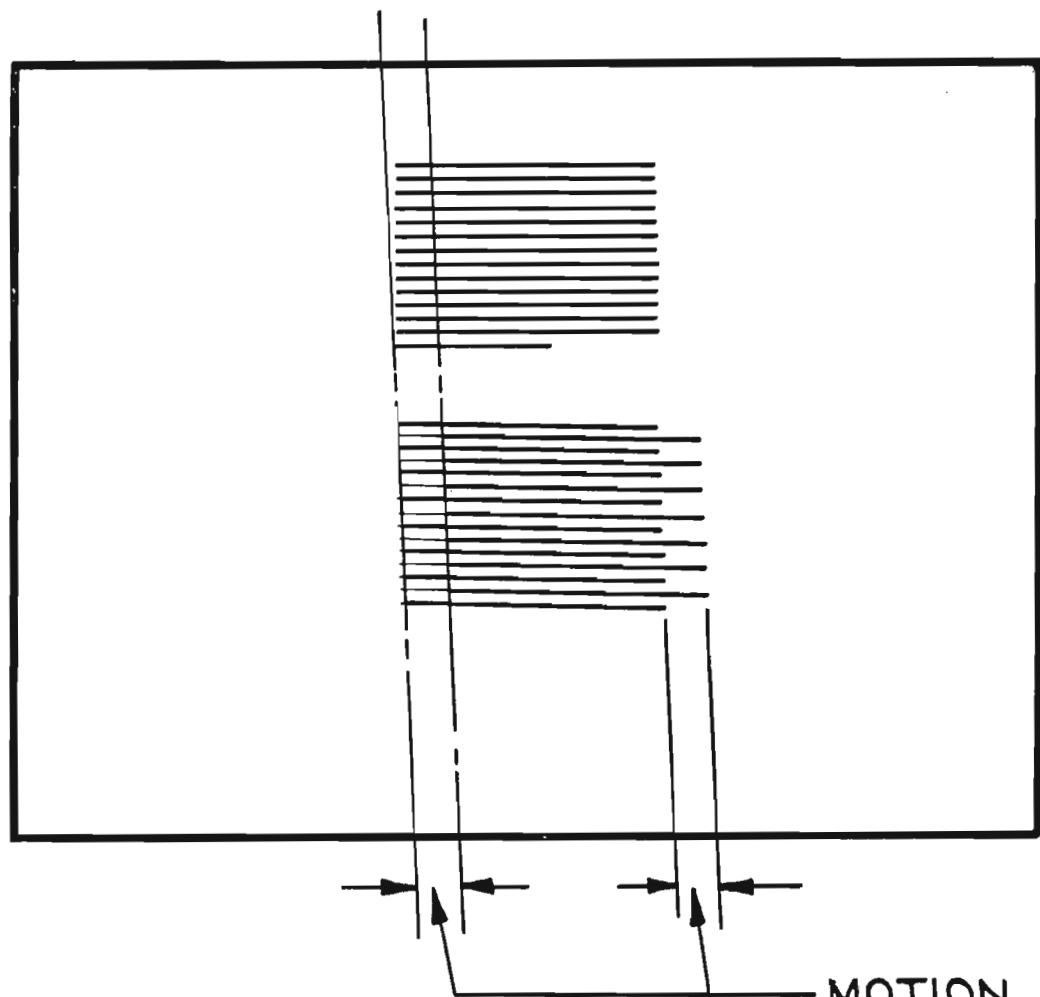

FIG. 3. Effect of horizontal motion of vertical edges in 2-to-1 interlaced system. Upper object stationary. Lower object moving to right.

also increase to accommodate the greater resolution required in the horizontal direction. The present system employs 525 lines, a number arrived at after thorough consideration of the related questions of channel width and resolution by the N.T.S.C. and the R.T.P.B.

One of the most interesting features of the television scanning system is the interlacing of the scanning lines, a scheme which is used to conserve bandwidth without sacrificing freedom from flicker. The sensation of flicker in a television image is related to the frequency of the illumination of the entire scene. It has no relation to the number of scanning lines nor to the frequency of the lines themselves. Therefore a system which causes the entire area of the scene to be illuminated at a higher frequency, even though the same lines are not scanned during successive cycles of illumination, results in greater freedom from flicker. Interlacing does just this by scanning part of the lines, uniformly distributed over the entire picture area, during one vertical scan, and the remaining part or parts during succeeding scans. Thus, without changing the velocity of the scanning beam in the horizontal direction, it is possible to obtain the effect of increased frequency of picture illumination.

In the standard two-to-one interlaced system, alternate lines are scanned con-

secutively from top to bottom after which the remaining lines, that fall in between those included in the first operation, are likewise scanned consecutively from top to bottom. (See Figs. 1 and 2 which illustrate the principle.) In the 525-line system, each of these groups, called a *field*, consists of  $262\frac{1}{2}$  lines. Two consecutive fields constitute a *frame* or complete picture of 525 lines. Each field is completed in  $1/60$  of a second and each pair of fields, or frame, in  $1/30$  of a second. The effect on the observer's eye, from the standpoint of flicker, is that of repetition of screen illumination every  $1/60$  of a second, yet the complete picture is spread out over  $1/30$  of a second.

The important result of interlacing is a reduction in the bandwidth of the frequencies generated in the picture signal, for a given value of limiting resolution, as compared to the bandwidth produced in a system using sequential scanning. This may be understood as follows: In either system, interlaced or sequential, the vertical scanning frequency must be the same and must be high enough to avoid the sensation of flicker. In the standard television system this frequency is 60 cycles per second. In a sequential system, *all* of the scanning lines must be traversed in the basic vertical scanning period. However, in the two-to-one interlaced system, only *half* of the scanning lines are traversed

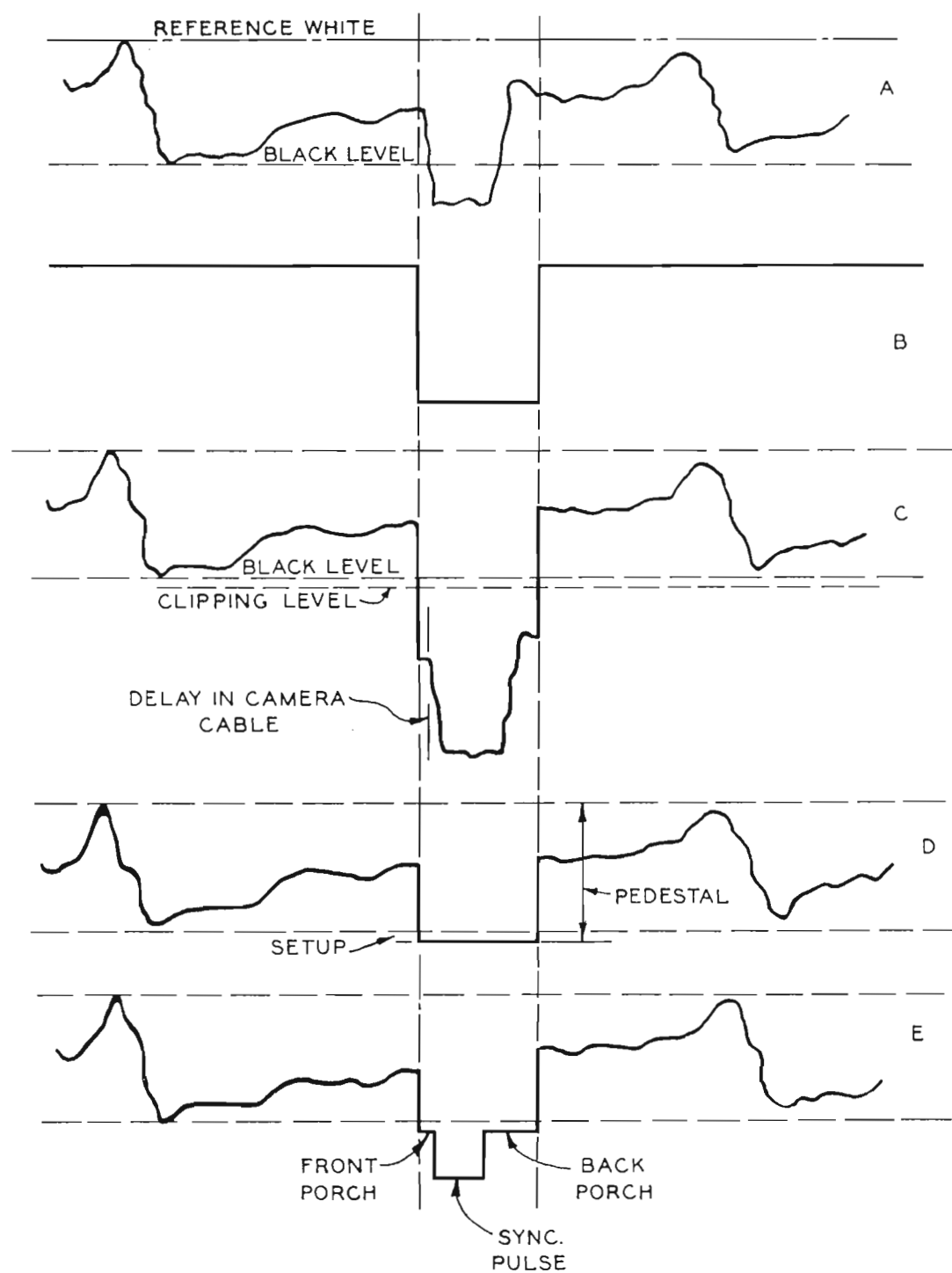

FIG. 4 (at left). Steps in the synthesis of picture signal:  
 A. Basic camera signal.  
 B. Kinescope blanking pulse.  
 C. Camera signal and blanking pulse combined.  
 D. Combined signal after clipping.  
 E. Combined signal after addition of sync pulse.

FIG. 5 (opposite page). RMA drawing illustrating approved wave shape of picture line amplifier output signal. This is one of the most important industry standards and is the one which determines the design of many of the components of the TV system.

in the same period. Thus, obviously, the horizontal velocity of motion of the aperture in the interlaced system is only half of the velocity in the sequential system, and likewise the signal frequencies are reduced by the same factor.

Interlaced scanning has certain inherent faults among which are interline flicker, and horizontal break-up when objects in the scene move in the horizontal direction.

Interline flicker results from the fact adjacent scanning lines are separated in time by  $1/60$  of a second, and that each line is repeated only at intervals of  $1/30$  of a second. It is apparent in any part of a scene where some detail of the scene is largely reproduced by a few adjacent scanning lines, and where the contrast in the detail is high. For example, the top edge of a wall which is oriented in the scene so as to be nearly parallel to the scanning lines might be reproduced by only two or three adjacent lines. The 30 cycle flickering of the line segments forming the edge of the wall would be quite noticeable. In the limiting condition, where the wall is exactly parallel to the scanning lines, the

edge would be reproduced by only one line repeated at intervals of  $1/30$  of a second. This is probably the worst possible condition, but one which is encountered rather infrequently. The top and bottom edges of the raster nearly always produce objectionable interline flicker because they are nearly parallel to the scanning lines. Interline flicker, like any other type of flicker, is most objectionable in scenes where the high lights are very bright and the contrast is high. When the brightness and contrast are low, interline flicker becomes negligible.

Break-up exists when an object in the scene moves in the horizontal direction rapidly enough so that the total motion in  $1/60$  of a second is equal to one or more picture elements. Then vertical edges of the object become jagged lines instead of smooth lines and there is apparent loss in horizontal resolution. This is roughly illustrated in Fig. 3 where two rectangles are shown, the upper one being stationary, and the lower one moving toward the right. The moving rectangle is shown as though it started moving from a position directly

below the other. In the moving rectangle, signal is generated, *in both fields*, from the starting position of the left edge because of the storage of information in the pickup tube during the interval between fields. Thus the storage effect causes actual blurring of the trailing edge of a moving object. This is illustrated by the thin extensions of the scanning lines in the second field at the left side. The leading edge of the moving object may have a more definite jagged appearance because the storage effect in the pickup tube cannot fill in the spaces. In non-storage pickup devices, both edges will appear jagged.

The geometrical distortion, illustrated by the tendency for the moving rectangle to become rhombic, is characteristic of any scanning system, whether interlaced or sequential.

Further consideration makes it clear that higher ratios of interlacing would produce these troubles in aggravated form which would be intolerable. Another objection to higher ratios of interlacing is an illusion of crawling of the scanning lines either up

PICTURE LINE AMPLIFIER STANDARD OUTPUT

SYNCHRONIZING SIGNAL AMPLITUDE  $\alpha$  SHALL BE HELD CONSTANT WITHIN  $\pm 4\%$  DURING ANY TRANSMISSION.  
 $\alpha$  MAY HAVE ANY VALUE BETWEEN 0.375 AND 0.625 VOLTS.  
 THE RATIO  $\frac{\alpha}{\alpha_{ref}}$  SHALL BE 0.25.  
 DRAWINGS NOT TO SCALE.

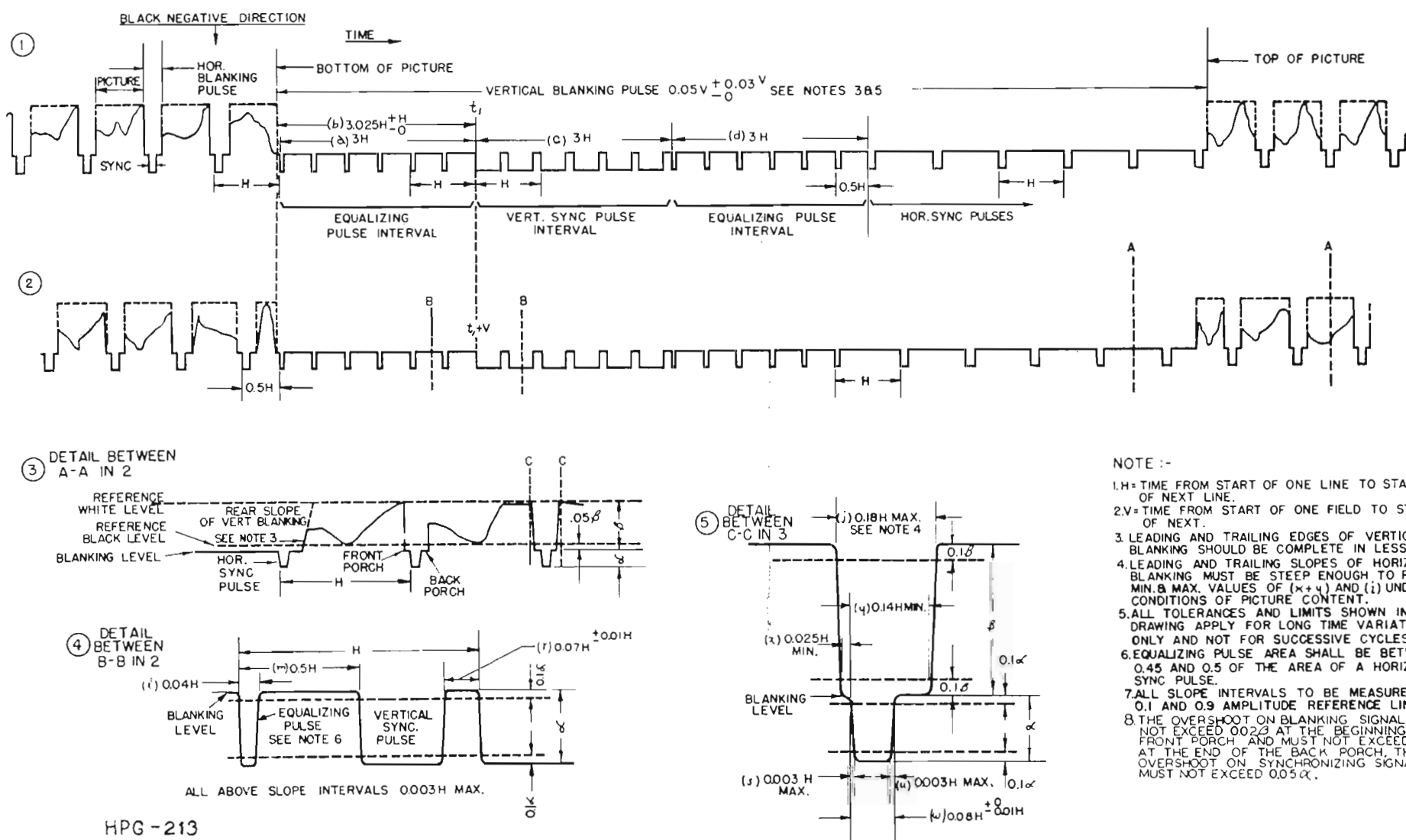

- NOTE :-
- 1.H = TIME FROM START OF ONE LINE TO START OF NEXT LINE.
  - 2.V = TIME FROM START OF ONE FIELD TO START OF NEXT.
  3. LEADING AND TRAILING EDGES OF VERTICAL BLANKING SHOULD BE COMPLETE IN LESS THAN 0.1H.
  4. LEADING AND TRAILING SLOPES OF HORIZONTAL BLANKING MUST BE STEEP ENOUGH TO PRESERVE MIN. & MAX. VALUES OF (x+y) AND (i) UNDER ALL CONDITIONS OF PICTURE CONTENT.
  5. ALL TOLERANCES AND LIMITS SHOWN IN THIS DRAWING APPLY FOR LONG TIME VARIATIONS ONLY AND NOT FOR SUCCESSIVE CYCLES.
  6. EQUALIZING PULSE AREA SHALL BE BETWEEN 0.45 AND 0.5 OF THE AREA OF A HORIZONTAL SYNC PULSE.
  7. ALL SLOPE INTERVALS TO BE MEASURED BETWEEN 0.1 AND 0.9 AMPLITUDE REFERENCE LINES.
  8. THE OVERSHOOT ON BLANKING SIGNAL MUST NOT EXCEED 0.023 AT THE BEGINNING OF THE FRONT PORCH AND MUST NOT EXCEED 0.053 AT THE END OF THE BACK PORCH. THE OVERSHOOT ON SYNCHRONIZING SIGNALS MUST NOT EXCEED 0.05 $\alpha$ .

HPG - 213  
 RMA SUB-COMMITTEE ON STUDIO FACILITIES APPROVED JAN. 22, 1946  
 REVISED OCT. 9, 1946

or down, depending on motion of the observer's eyes. The effect is extremely annoying and tends to distract the observer's attention from the scene.

The type of interlacing adopted for commercial television is known as *odd-line* interlacing. The total number of lines is an odd integer. Thus the number of lines in each of two equal fields is a whole number plus a half. In this system, the use of perfectly uniform vertical scanning periods (equal to half the product of the total number of lines and the period of one line) and constant vertical scanning amplitude, results in consecutive fields which are displaced in space with respect to each other by half a line, thus producing interlacing of the lines, as illustrated by the 13-line system in Fig. 1. Specifically, as stated above, the total number of lines in the standard system is 525; the number per field is  $262\frac{1}{2}$ ; the vertical scanning frequency is 60 cycles per second; the number of complete pictures (frames) per second is 30; and the horizontal scanning frequency is  $60 \times 262\frac{1}{2}$ , or 15,750 cycles per second.

Interlacing may also be obtained when the total number of lines is an *even* number, but *even-line* interlacing requires that alternate fields be displaced vertically one half line with respect to each other by the addition of a 30-cycle component to the amplitude of the vertical scanning sawtooth wave (see Fig. 2). This frame frequency component must have a degree of accuracy that is impractical either to attain or maintain. Hence even-line interlacing is not used for commercial television.

One other factor has influenced the choice of the particular number of scanning lines. This is the need for an exact integral relationship between horizontal and vertical scanning frequencies. It has been the practice to attain this relationship by using a series of electronic counting circuits. To secure a high degree of stability, the characteristic count of each circuit was limited to a small integer less than ten. Thus the h/v frequency ratio was required to be related to the combined product of several small integers. In the RCA synchronizing generator equipment, for example, there are four such circuits

counting the numbers 7, 5, 5, and 3 respectively. The combined product of these four numbers is 525, the number of lines per frame. The product of 525 and 60 is 31,500 which is the frequency of the master oscillator in the sync. generator. To obtain the correct frequency for the horizontal scanning system, another counter circuit divides the master oscillator frequency by two to yield the required frequency of 15,750 cycles.

**Synthesis of the Picture Signal**

The basic part of the signal applied to the reproducer is the series of waves and pulses generated during the actual scanning line periods in the pickup or camera tube. No matter what else is done in the equipment intervening between the two ends of the system, this basic part of the signal should be preserved in character with the greatest possible accuracy. However, during the retrace periods, the pickup tube may generate signals which are spurious or which at least do not contain valuable picture information. Furthermore, retrace lines in the reproducing tube itself, espe-

cially during vertical retrace, detract from the picture. It is therefore desirable to include in the picture signal, components which will eliminate spurious signals during retrace and the retrace lines themselves in the reproducer. These results may be obtained by adding synthetically some pulses known as blanking pulses.

Blanking pulses are applied to the scanning beams in both the camera tube and the kinescope in the receiver. *Camera blanking* pulses are used only in the pickup device and never appear directly in the final signal radiated to the receiver. They serve to close the scanning aperture in the camera tube during retrace periods. In orthicon tubes, the picture signal during retrace thus goes to reference black or to some level constantly related to reference black. This is a useful result to be discussed later. In iconoscopes, no such constant relationship to black exists during retrace, and the only function of camera blanking is to prevent spurious discharge of the mosaic during the retrace periods.

*Kinescope blanking* or *picture blanking* pulses are somewhat wider than corresponding camera blanking pulses. They become integral parts of the signal radiated to the receiver.

The function of the kinescope blanking pulses is to suppress the scanning beam in the kinescope (reproducing tube), or in other words, to close the aperture in the receiver during the retrace periods, both horizontal and vertical. They are simple rectangular pulses having time duration slightly longer than the actual retrace periods in order to trim up the edges of the picture and eliminate any ragged appearance. They are produced in the sync generator from the same basic timing circuits that generate the scanning signals; hence they are accurately synchronized with the retrace periods. Typical wave shapes of a basic camera signal and blanking pulses are illustrated in Figs. 4, A and B respectively. Only parts of two scanning line periods are shown, and the pulse in B is therefore a single *horizontal blanking pulse*. The result of adding the signals in A and B is shown in C where it may be seen that the unwanted spurious part of the camera signal has been pushed downward out of the territory of the basic picture signal. This unwanted part may now be clipped off and discarded leaving the signal illustrated in D.

The blanking signal, shown only in part in Fig. 4, B, actually contains pulses for removing visible lines during both horizontal and vertical retrace periods. The

horizontal pulses recur at intervals of  $1/15,750$  of a second and are only a small fraction of a line in duration, but at times corresponding to the bottom of the pictures they are replaced by *vertical blanking pulses* which are just like the horizontal pulses except that they are much longer in duration, approximately 15 scanning lines long, because the vertical retrace is much slower than the horizontal. The period of recurrence of the vertical blanking pulses is  $1/60$  of a second, of course. Both horizontal and vertical blanking pulses and their approximate relationship are shown in diagrams 1 and 2 of Fig. 5.

The picture signal shown in D of Fig. 4 may be considered as partly natural and partly synthetic. It is important to point out here that the natural part, or basic camera signal, may contain certain noise components arising from the fact that the output of the pickup tube usually is not large compared to the noise threshold of the first picture amplifier stage or some other part of the system such as the scanning beam in an image orthicon. On the other hand, the blanking pulses, or synthetic parts of the signal, are added at a relatively high level part of the system and are therefore noise-free. The importance of noise-free blanking pulses will become apparent in the discussions of other functions which they perform.

Details of horizontal blanking pulse shape are shown in diagram 5 of Fig. 5. That part of the diagram below the point marked Blanking Level is a sync pulse which will be considered later. The overall vertical dimension  $\beta$  is the maximum height of a blanking pulse. Thus the top horizontal line is Reference White Level as indicated in diagram 3. The duration or width of the pulse must be sufficient to cover the horizontal retrace in the most inefficient receiver. Thus the circuit limitations in such receivers set a minimum limit to the horizontal blanking width which was the basis for the RMA specification in Fig. 5. This minimum is indicated by the width near the peak (lower end) of the pulse and is prescribed by the sum of two dimensions  $x + y$ , the value of which is 16.5% of the horizontal period,  $H$ . The impossibility of producing infinitely steep sides on the pulse is recognized in the greater maximum width (18% of  $H$ ) allowed at the upper end of the pulse and in the obviously sloped sides.

Because of inevitable discrepancies at the extremes of the sides of the pulse, all measurements of pulse widths are made at levels slightly removed from the ex-

tremes of the sides. These levels are shown by dotted horizontal lines, in diagram 5 of Fig. 5, spaced 10% of  $\beta$  from top and bottom of the pulse.

Details of the vertical blanking pulses are shown in diagrams 1 and 3 of Fig. 5. The width of the pulses is not limited by circuit considerations, as is the width of horizontal blanking. The limitation here is the requirement of television film projectors of the intermittent type that the scene be projected on the pickup tube only during the vertical blanking period. The maximum period of 8% is ample for the operation of present-day film pickup systems, the criterion being that enough time must be allowed for projection so that there is adequate storage of photoelectric charges on the sensitive surface of the pickup tube. The minimum period of 5% is an indication of expected system improvements in the future when it will be possible to reduce waste of picture transmission time in vertical blanking. The present usefulness of the 5% minimum is to require receiver manufacturers to maintain vertical retrace periods at less than 5% and thus avoid the need for modifying old receivers when improvements are made in the system. The problem of film projectors is discussed in a later section.

The final step in synthesizing the complete composite picture signal which goes to the modulator in the transmitter is to add the synchronizing pulses which are required for triggering the scanning circuits in the receiver. These pulses, like blanking pulses, are essentially rectangular in shape. The blanking pulses serve as bases or pedestals (inverted) for the sync pulses as shown in E of Fig. 4. Here is one of the most important reasons for having noise-free blanking. The synchronizing function in the receiver is a very critical one, and it is important that nothing be allowed to distort the sync pulses either in shape or timing as noise during the blanking intervals would do. The nature of the vertical sync signal is rather complicated and is not illustrated in Fig. 4, but will be discussed later along with other details of synchronizing.

The sync signal is not added individually to the output of each camera, but is added at the studio output so that switching from one camera to another will not cause even momentary interruptions in the flow of synchronizing information to the receivers.

•

(MR. ROE'S ARTICLE WILL BE CONTINUED IN THE NEXT ISSUE OF BROADCAST NEWS)



**RCA Field-Intensity Meter**  
**Type WX-1A**  
**50 to 220 Mc**



**NEW** *field-intensity meter*

**—for the television and FM bands**

**SPECIFICATIONS**

Freq. Range . . . . . 50 to 220 Mc  
 Sensitivity . . . . . 5 microvolts to  
 20 microvolts/meter,  
 depending on frequency  
 I-F Bandwidth . . . . . 150 kc  
 FM Adjacent Channel  
 Selectivity . . . . . 65 to 1  
 FM Band Image Ratio . . 130 to 1  
 Power Supply . . . . . Built-in 6-v,  
 voltage-regulated  
 (a-c power supply  
 also available)  
 Weight  
 Meter . . . . . 43½ lbs.  
 Antenna  
 (including tripod) . . . . 15 lbs.  
 Size . . . . . 19" L x 14½" H x 13" D

THE WX-1A meets the strict requirements of FM and TV engineers for a field-intensity meter of laboratory accuracy covering television, FM, and AM services between 50 and 220 Mc. Its high sensitivity permits minimum readings ranging from as low as 5 microvolts per meter at 50 Mc, to 20 microvolts per meter at 200 Mc.

Completely self-contained, the WX-1A includes a very stable superheterodyne receiver. Selectivity characteristic is down 65 to 1 on adjacent FM channels. Image ratio is 130 to 1 at 100 Mc. A 2-stage audio amplifier drives a built-in loudspeaker for continuous audio monitoring of the signals being measured.

Separate output terminals provide for convenient use with the standard Easterline-Angus recorder. The built-in vibrator power supply includes its own voltage regulator. The antenna . . . furnished with each WX-1A...is adjustable for horizontal or vertical polarization.

For accurate data on the service area of any TV, FM, or AM station in the uhf —and for authoritative coverage information for FCC proof-of-performance—the WX-1A is second to none. Complete details are available from your RCA Broadcast Sales Engineer. Or from Dept. 191B, RCA Engineering Products, Camden, N. J.

The One Equipment Source for Everything in **BROADCASTING** —is RCA



**BROADCAST EQUIPMENT**  
**RADIO CORPORATION of AMERICA**  
**ENGINEERING PRODUCTS DEPARTMENT, CAMDEN, N.J.**

In Canada: RCA VICTOR Company Limited, Montreal

# Everything for TV...

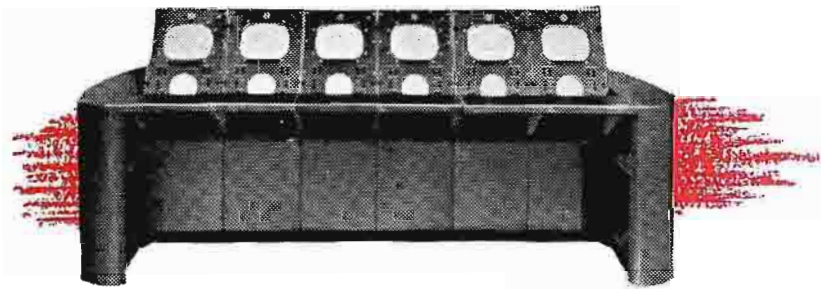

**RCA De Luxe Video Console.** Everything you need to monitor, control, and switch camera pictures. "Add-a-unit" design enables you to expand these facilities as your station grows.

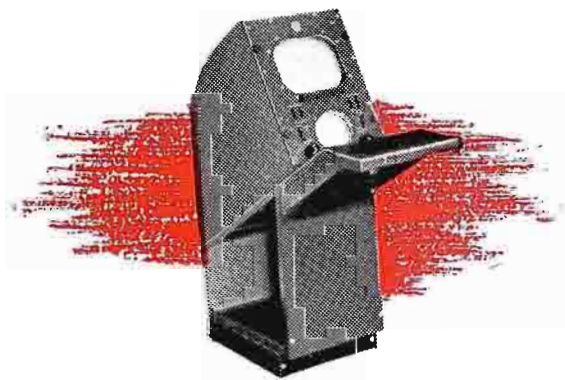

**RCA Camera Control Type TK-10A.** Makes it practical to watch and control the picture quality of station camera. Same size and appearance as RCA's switching units, film camera control, and preview- and line-monitoring units. These units can be grouped in any combination to form a video console (shown above).

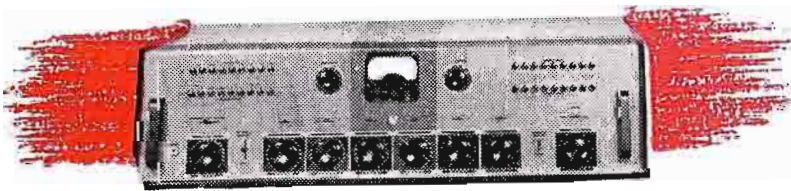

**RCA Studio Consolette Type 76-C4.** This flexible and easy-to-operate control unit performs all the audio amplifying, monitoring, and control functions of a TV station—large or small. Can be used for single- or two-studio operation, and for two transcription turntables.

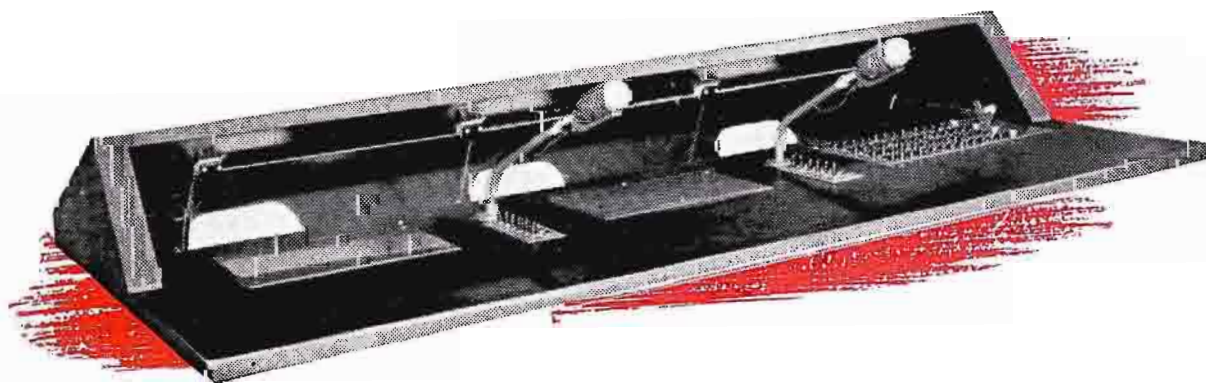

**RCA Program Directors Console Type TC-5A.** Television's most up-to-date directors' control. Includes large-size picture monitors for the studio outgoing line, for previewing, and for "on-the-air" monitoring. All switching under finger-tip control. Low height for full studio visibility. Recessed monitors for maximum image brightness in a fully-lighted control room.

**T**HAT PICTURE you see over there is a studio control room for a medium-size television station—complete by RCA, from sight to sound.

This room virtually puts entire programming under "push-button" supervision. From here you control and monitor studio programs . . . sound and picture . . . switch between *all* cameras, switch to network or remote programs, control and monitor recorded sound, monitor the programs on the air.

In this room are large picture monitors for previewing signals from remotes or networks and from the studio cameras. In this room also is an audio consolette that controls all program sound lines—from the studio microphones, network audio line, studio and announce microphones, and from the turntables shown in the foreground. A program console . . . with its picture monitor for viewing the studio line and the on-the-air picture . . . co-ordinates the programming. Nothing included in this room that should not be there. Nothing omitted that should be included.

Why do most TV stations go RCA all the way on studio control-room equipment?

Because RCA control-room equipment has design flexibility to meet every station's need and budget. Because RCA control-room equipment is *unit-built* . . . permits easy and economical addition of extra units without a worry about discarding the original equipment. Because a single company makes the entire line . . . *and backs it up!*

For professional assistance in planning your television station, call in an RCA Specialist. Or write Dept. 19 FD, RCA Engineering Products, Camden, N. J.

The One Source for Everything in **TV**—is RCA

# entire studio control rooms, *for instance*—

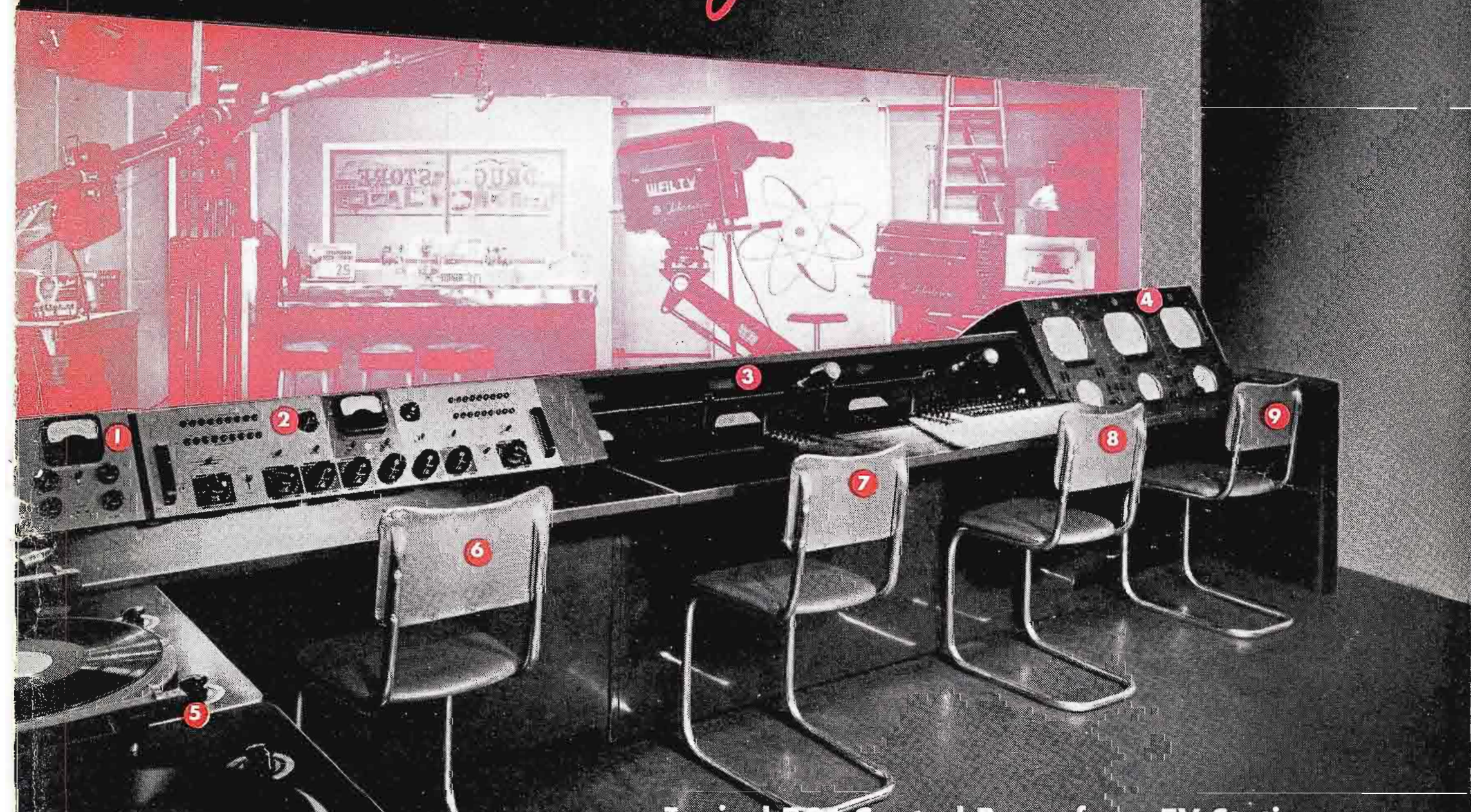

**Typical RCA Control Room for a TV Station**  
— one of more than 20 possible layouts to  
meet any station requirement, large or small.

- |  |                               |
|--|-------------------------------|
| 1 Audio Consolette—for<br>separate channel | 5 Transcription Turntables    |
| 2 Audio Consolette                         | 6 Audio Operator Position     |
| 3 Program Directors' Console               | 7 Program Director Position   |
| 4 Video Console                            | 8 Technical Director Position |
|  | 9 Video Operator Position     |



**TELEVISION BROADCAST EQUIPMENT**  
**RADIO CORPORATION of AMERICA**  
**ENGINEERING PRODUCTS DEPARTMENT, CAMDEN, N. J.**

In Canada: RCA VICTOR Company Limited, Montreal

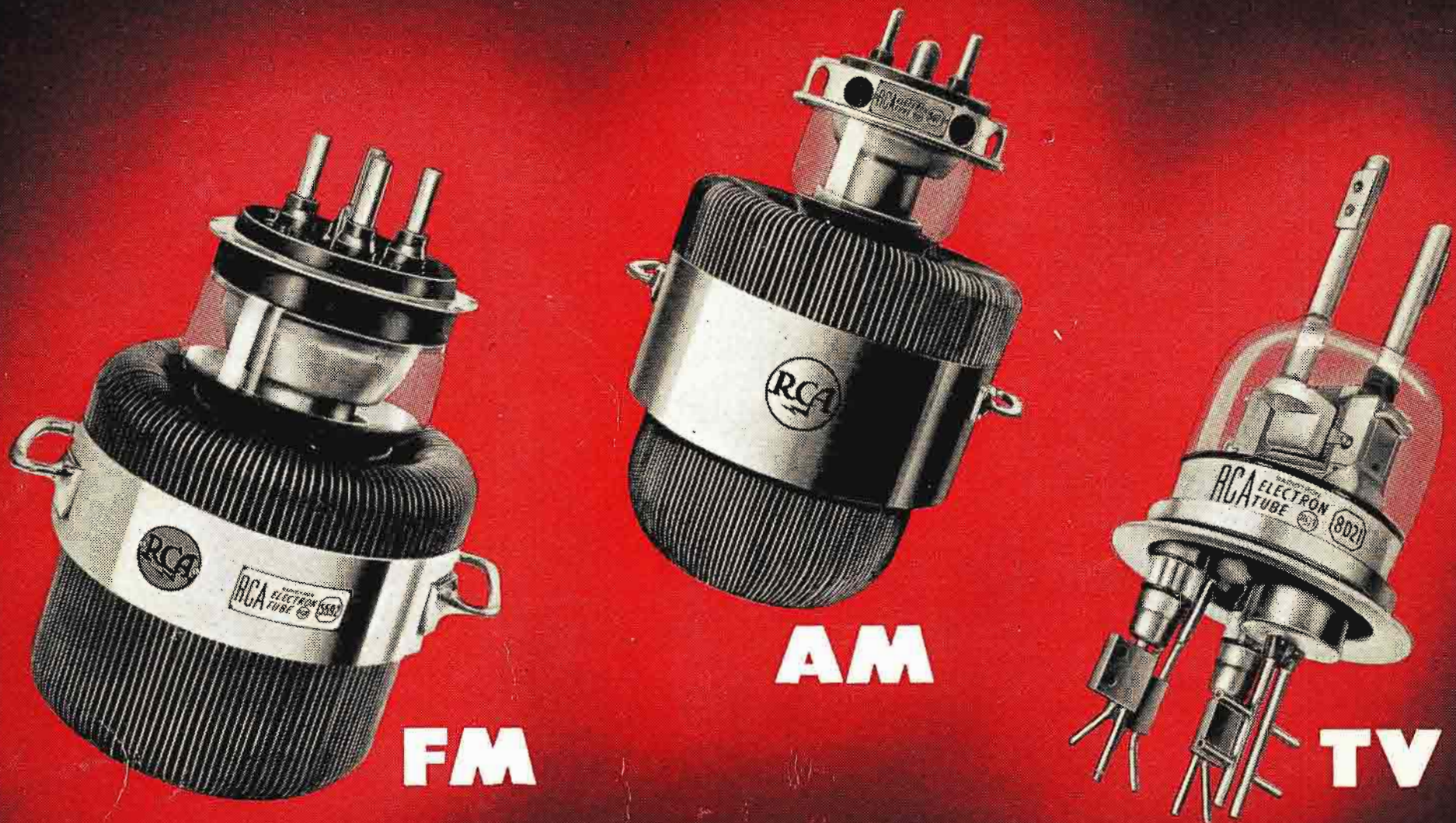

RCA-5592, used in 50-kw  
FM transmitters

RCA-5671, with thoriated filament,  
used in 50-kw AM transmitters

RCA-8D21, used in 5-kw  
television transmitters

## RCA covers the field

RCA has the most complete and up-to-date line of tubes in the broadcast field.

RCA's years of experience in tube research and development have resulted in new and improved types for AM, FM, and TV broadcasting . . . tubes that have advanced the art of broadcasting in all its phases.

Year after year, RCA tubes have set the pace in quality, performance, and value. They have won an unequalled reputation for engineering excellence, dependability, and

true operating economy. That's why experienced broadcasters buy RCA tubes.

For your convenience, RCA tubes are now available from your local RCA Tube Distributor or directly from RCA. For information on any RCA tube, write RCA, Commercial Engineering, Section FP 36, Harrison, N.J.

The world's most modern tube plant...

**RCA, LANCASTER, PA.**



THE FOUNTAINHEAD OF MODERN TUBE DEVELOPMENT IS RCA



**TUBE DEPARTMENT**

**RADIO CORPORATION of AMERICA**

**HARRISON, N. J.**